

Сумматор энергии U1600

Архангельск (8182)63-90-72
Астана (7172)727-132
Астрахань (8512)99-46-04
Барнаул (3852)73-04-60
Белгород (4722)40-23-64
Брянск (4832)59-03-52
Владивосток (423)249-28-31
Волгоград (844)278-03-48
Вологда (8172)26-41-59
Воронеж (473)204-51-73
Екатеринбург (343)384-55-89
Иваново (4932)77-34-06
Ижевск (3412)26-03-58
Казань (843)206-01-48

Калининград (4012)72-03-81
Калуга (4842)92-23-67
Кемерово (3842)65-04-62
Киров (8332)68-02-04
Краснодар (861)203-40-90
Красноярск (391)204-63-61
Курск (4712)77-13-04
Липецк (4742)52-20-81
Магнитогорск (3519)55-03-13
Москва (495)268-04-70
Мурманск (8152)59-64-93
Набережные Челны (8552)20-53-41
Нижний Новгород (831)429-08-12
Новокузнецк (3843)20-46-81

Новосибирск (383)227-86-73
Омск (3812)21-46-40
Орел (4862)44-53-42
Оренбург (3532)37-68-04
Пенза (8412)22-31-16
Пермь (342)205-81-47
Ростов-на-Дону (863)308-18-15
Рязань (4912)46-61-64
Самара (846)206-03-16
Санкт-Петербург (812)309-46-40
Саратов (845)249-38-78
Севастополь (8692)22-31-93
Симферополь (3652)67-13-56
Смоленск (4812)29-41-54

Сочи (862)225-72-31
Ставрополь (8652)20-65-13
Сургут (3462)77-98-35
Тверь (4822)63-31-35
Томск (3822)98-41-53
Тула (4872)74-02-29
Тюмень (3452)66-21-18
Ульяновск (8422)24-23-59
Уфа (347)229-48-12
Хабаровск (4212)92-98-04
Челябинск (351)202-03-61
Череповец (8202)49-02-64
Ярославль (4852)69-52-93

Единый адрес для всех регионов: cmn@nt-rt.ru || www.camille-bauer.nt-rt.ru

U1600 ECS ENERGY • CONTROL • SYSTEM

3-348-874-01
5/8.14

- 32 processing channels for the determination of energy, power and costs based upon input pulses
- **Energy Control Language** for analysis programming, monitoring and optimization
- 24 inputs for the processing of SO pulses and digital conditions
- 4 relay outputs for controlling external processes
- Two RS 232 interfaces (19.2 kBit/s) for connecting PC, modem, printer and radio controlled clock
- Two ECS LAN interfaces for interconnection of individual summators over great distances

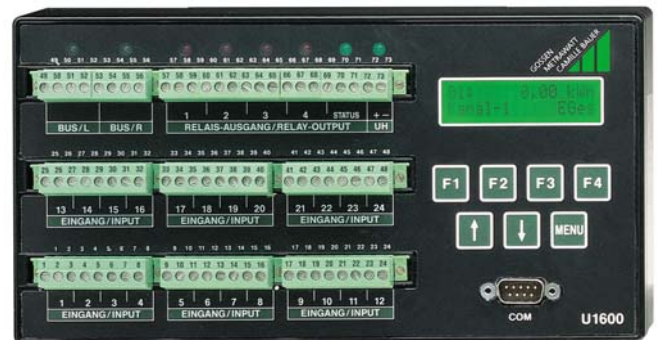

Applications

The U1600 summator is capable of processing up to 24 pulse signals and digital conditions. All electrical and non-electrical forms of energy can thus be logged, visualized, optimized and billed to individual cost centers.

32 processing channels are available for the 24 input signals. Meter pulses are acquired and summed over defined periods of time at a programmable interval. Energy, power and consumption are determined for each channel, and are processed and saved to memory as load profiles with corresponding maximum values. 8 virtual channels can be used together with arithmetic operations for combination into groups of power consumers, and for subdivision into cost centers.

The U1600 summator is equipped with 4 relay outputs (change-over contacts) for the control of external processes. They can be driven directly from a PC via the interface, or by means of user-specific background programs.

Communication with the PC or remote querying with a modem is accomplished via the RS 232 interface (19.2 kBit/s). Beyond this, a radio controlled clock for system time synchronization or a printer for the generation of reports can be connected as well.

Individual summators can be interconnected over great distances via the multi-master compatible **ECS LAN** with freely selectable network topology, and are provided with unlimited access to data available from all network users.

Thanks to integrated high level intelligence and the customized ECL programming language, the U1600 summator is highly suitable for customer-specific billing, analysis, monitoring and optimization independent of the Energy Control System.

The compact housing and electrical protection have been designed for rugged industrial use, and allow for mounting to a top-hat rail in accordance with EN 50022. It can also be screw mounted or integrated into the control panel. Easy installation is facilitated through the use of plug-in screw terminals.

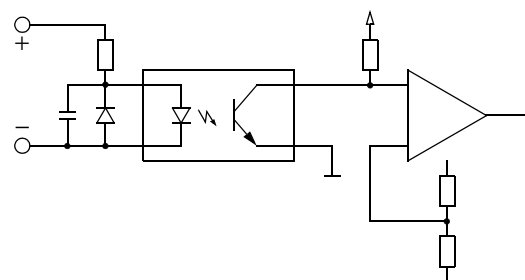

Figure 1, Schematic Diagram, Meter Input

Applicable Regulations and Standards

VDE 0411, Part 1/ IEC 348	Regulations for electronic measuring and control devices, part 1, safety measures
VDE 0110	Insulation coordination
DIN 40050	Degrees of protection, protection against particulate and water for electrical equipment
EN 55022	Interference suppression for data processing systems
IEC 255-4	High-frequency disturbance test
IEC 801-2 / -3 / -4	Electromagnetic compatibility
DIN 43864	Current interface for pulse transmission between impulse meters and tariff devices
IEC 1036/ VDE 0418, Part 7	Alternating current, static watt-hour meters for active energy (classes 1 and 2) (points 5 through 5.4 if the corresponding requirements are stricter than those set forth in VDE 0411)
VDE 0106, Part 100	Protection against electrical shock / finger contact safety

Symbols and their Meanings

Symbol	Meaning
X	Measured quantity, input quantity
Y	Output quantity
H	Auxiliary voltage
Hn	Auxiliary voltage nominal value

Memory Capabilities per Channel

Energy

Cumulative Energy as of a Defined Starting Point	
E total	independent of tariff
E total T1	from tariff 1 only
E total T2	from tariff 2 only
E total T1T2	from tariff 1 + tariff 2
Cumulative Energy for Defined Time Periods	
E Day	for the current day and each of the last 10 days
E Month	for the current month and each of the last 12 months
E Year	for the current year, last year and the year before last
E int	for all stored measuring intervals (measurement data list)
Measuring Interval Maximum Values with Date and Time	
E maxint	the 10 highest values for all measuring intervals as of a defined starting point
E maxDay	respective daily peak values for the current day and the last 10 days
E maxMonth	respective daily peak values for the current month and the last 12 months
E maxYear	the highest value from the current year, last year and the year before last

Costs

Cumulative Costs as of a Defined Starting Point	
CostT1	from tariff 1 only
CostT2	from tariff 2 only
CostT1T2	from tariff 1 + tariff 2

Power

Instantaneous Value	
P inst	determined from the time interval between the last two meter pulses
Measuring Interval Mean Values	
P int	for all stored measuring intervals (measurement data list)
Maximum Mean Value Memory Time with a Measuring Interval of 0.25 Hours	
for 1 channel: 113 days	for 18 channels: 17 days
for 3 channels: 68 days	for 24 channels: 13 days
Measuring Interval Maximum Values with Date and Time	
P maxint	the 10 highest values for all measuring intervals as of a defined starting point
P maxDay	respective daily peak values for the current day and the last 10 days
P maxMonth	respective daily peak values for the current month and the last 12 months
P maxYear	the highest value for the current year, last year and the year before last

Technical Data

Input

Input Quantity	direct current (square-wave pulse, SO compatible)
Number of Inputs	24
Allowable Input Quantity Range	signal level: H 4.5 V ... 24 V L 0 V ... 2.0 V
Allowable Excessive Input Continuous Intermittent	48 V 60 V
Allowable Switching Elements	semiconductor switches, relays
Input Impedance	5 k Ω
Input Wiring	see schematic diagram, figure 1
Electrical Isolation	by means of optocoupler
Signal Duration	10 ms ... 2.55 s
Signal Pause	10 ms
Signal Frequency	< 50 Hz
Meter Range Upper Limit	22 places of which 15 are usable

Display

Type	LCD (illuminated)
Character Height	5.55 mm (2 lines of 16 characters each)
Displayed Data	meter reading, name, power values, costs and other similar data

Output

Binary Output	
Switching Elements	relays
Number of Relays	4
Contacts	changeover
Switching Capacity	50 V, 0.5 A
Switching Cycles	> 20 x 10 ⁶ at nominal load

RS 232 Interface

Quantity	2
Connectors	sub-miniature D9 pin-plug connector
Connectable Devices	terminal, printer, PC, modem
Number of Data Bits	8
Data Transmission Speed	COM (1): 19.2 kBit/s COM (2): 19.2 kBit/s
Parity	none
Operating Mode	full-duplex handshake, Xon / Xoff

RS 485 Interface

Quantity	2
Connectors	screw-in plug connector
Operating Mode	half-duplex or full-duplex
Connectable Devices	LAN (local area network)
Data Protocol	HDLC / SDLC (adapted to multi-master requirements)

Measurement Value Storage

Storage Method	consecutive
Memory Depth	for 32 channels: 10 days for 11 channels: 1 month
Memory Life Span	10 years at 65° C with voltage-free device

Resetting Meters Readings to Zero	via PC or device keypad
-----------------------------------	-------------------------

Time Generator for Date and Clock

Smallest Unit of Time	1 s
Allowable Deviation	10 ppm = 1.8 min/year

Reference Conditions

In accordance with IEC 688

Functions Monitoring

Status Display	via LED at front panel
Status Relay	changeover contact
Switching Capacity	50 V, 0.5 A
Switching Cycles	> 20 x 10 ⁶ at nominal load

Influencing Quantities and Influence Errors

Influencing Quantity	Nominal Range of Use	Allowable Influence Error
Temperature	0° C ... 55° C	no influence error
EM Fields	severity level 2	no influence error
Active Power	pulse frequency \leq 1 Hz \leq 20 Hz	

Electrical Safety

Safety Class	I
Overvoltage Category	III
Nominal Insulation Voltage	inputs, outputs, interface connections: 50 V
Auxiliary Voltage	250 V
Protection against EM Fields	severity level 2
Surge Withstand Capability	5 kV, 1.2 / 50 μ s, 0.5 Ws
Interference Suppression	class A in accordance with EN 55022
Test Voltages	
Input – Housing	1.5 kV
Input – Output	3.0 kV
Auxiliary Voltage – Input	0.5 kV

Resistance to Climatic Conditions

Climatic Category	3z / -25 / 75
Relative Humidity	75%
Temperature Range Operation / Function Storage, Transport	- 10° C ... + 55° C - 25° C ... + 75° C

U1600

ECS ENERGY • CONTROL • SYSTEM

Auxiliary Power Supply

Alternating Voltage	
Nominal Range of Use	80 V ... 250 V
Frequency Range	45 Hz ... 65 Hz
Power Consumption	19 VA
Direct Voltage	
Nominal Range of Use	20 V ... 80 V or 80 V ... 250 V
Power Consumption	15 W
Inrush Current	10 A, 100 ms where H = 48 V
Supply Voltage for External Circuits	
Voltage Range	24 V ± 2 V direct voltage
Load Capacity	max. 0.4 A
Electrical Isolation	from all other circuits

Mechanical Design

Housing Material	die-cast aluminum
Dimensions	240 x 125 x 80 mm
Mounting Position	any
Mounting	top-hat rail per EN 50022 / 35 mm, or screw mount to plate
Protection	housing: IP 40 terminals: IP 20
Weight	2.3 kg

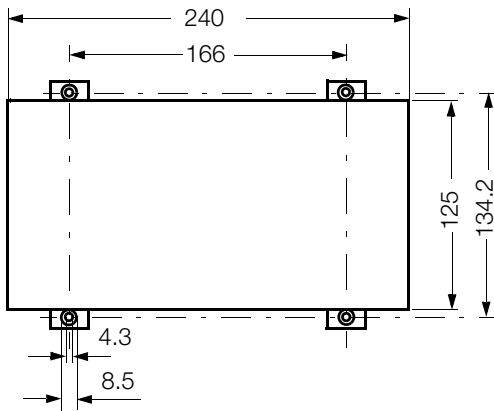

Figure 2, Dimensions

Mounting to Top-Hat Rail

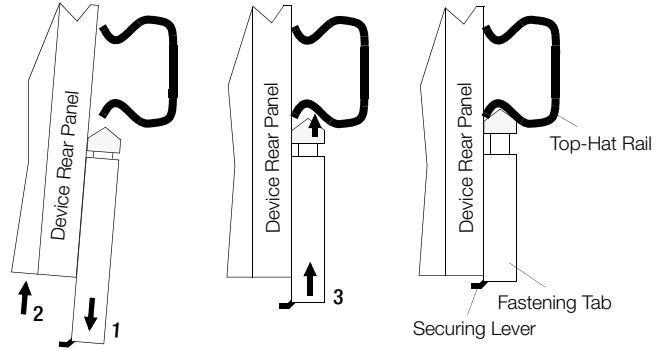

Figure 3, Opening the Fastening Tabs

Press the securing lever down, and pull the fastening tab out to its last snap-in position. Follow the same procedure for the other fastening tab. Then set the summator onto the top-hat rail and push both fastening tabs all the way in until they snap into position.

Electrical Connection

Signal Cables

Connectors	screw terminals
Allowable Connector Cable Cross-Section	2.5 mm ²

Auxiliary Voltage Cables

Connectors	inlet connector for AC, jack sockets for DC (user retrofit from inlet connector to jack sockets)
------------	--

Terminal Assignments

49	50	51	52	53	54	55	56	57	58	59	60	61	62	63	64	65	66	67	68	69	70	71	72	73		
+EA	+E	+EA	+E																					+24V		
Bus / L				Bus / R				Relay 1				Relay 2				Relay 3				Relay 4				Status		UH
25	26	27	28	29	30	31	32	33	34	35	36	37	38	39	40	41	42	43	44	45	46	47	48			
+E13	+E14	+E15	+E16					+E17	+E18	+E19	+E20					+E21	+E22	+E23	+E24							
Eingang / Input								Eingang / Input								Eingang / Input										
1	2	3	4	5	6	7	8	9	10	11	12	13	14	15	16	17	18	19	20	21	22	23	24			
+E1	+E2	+E3	+E4					+E5	+E6	+E7	+E8					+E9	+E10	+E11	+E12							
Eingang / Input								Eingang / Input								Eingang / Input										



80 ... 250 V AC
45 ... 65 Hz

20 ... 80 V DC /
80 ... 250 V DC



Terminal	Function	Designation
1	Input 1	+
2	Input 1	-
3	Input 2	+
4	Input 2	-
5	Input 3	+
6	Input 3	-
7	Input 4	+
8	Input 4	-
9	Input 5	+
10	Input 5	-
11	Input 6	+
12	Input 6	-
13	Input 7	+
14	Input 7	-
15	Input 8	+
16	Input 8	-
17	Input 9	+
18	Input 9	-
19	Input 10	+
20	Input 10	-
21	Input 11	+
22	Input 11	-
23	Input 12	+
24	Input 12	-
25	Input 13	+
26	Input 13	-
27	Input 14	+
28	Input 14	-
29	Input 15	+
30	Input 15	-
31	Input 16	+
32	Input 16	-
33	Input 17	+
34	Input 17	-
35	Input 18	+
36	Input 18	-
37	Input 19	+
38	Input 19	-

Terminal	Function	Designation
39	Input 20	+
40	Input 20	-
41	Input 21	+
42	Input 21	-
43	Input 22	+
44	Input 22	-
45	Input 23	+
46	Input 23	-
47	Input 24	+
48	Input 24	-
49	Bus Left	EA +
50	Bus Left	EA -
51	Bus Left	E +
52	Bus Left	E -
53	Bus Right	EA +
54	Bus Right	EA -
55	Bus Right	E +
56	Bus Right	E -
57	Relay 1	Ö
58	Relay 1	W
59	Relay 1	Sch
60	Relay 2	Ö
61	Relay 2	W
62	Relay 2	Sch
63	Relay 3	Ö
64	Relay 3	W
65	Relay 3	Sch
66	Relay 4	Ö
67	Relay 4	W
68	Relay 4	Sch
69	Status Relay	Ö
70	Status Relay	W
71	Status Relay	Sch
72	Meter Power Supply	+ 24 V
73	Meter Power Supply	0 V

Note: Meter power supply delivers 24 V DC, max. 0.4 A (short-circuit proof)

U1600

ECS ENERGY • CONTROL • SYSTEM

Connector Pin Assignments, Sub-Miniature D9 Plug for COM (1)

Pin Number	Function
1	
2	RXD
3	TXD
4	
5	signal ground
6	
7	RTS (+12 V)
8	
9	

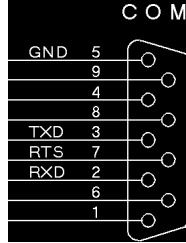

Connector Pin Assignments, Sub-Miniature D9 Plug for COM (2)

Pin Number	Function
1	
2	
3	
4	TXD
5	signal ground
6	
7	RTS (+12 V)
8	
9	RXD

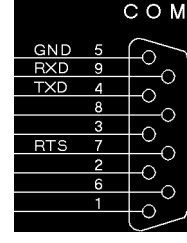

The cable with the designation Z5232 000 R0001 must be used for connecting a PC or a terminal.

Summator Configuration

Configuration of the U1601 summator is plainly structured. Differentiation is made amongst four different configuration groups (see figure 4, setup parameters).

The “general” parameters apply to all of the summators, and thus demonstrate average characteristics, whereas the “channel specific” parameters are directly associated with each individual channel.

The configuration groups “RS 232” and “ECS LAN” apply to the serial interface (RS 232) and the ECS LAN system bus (Energy Control System Local Area Network).

A six character password protects the individual parameters against unauthorized changes.

Basic Configuration

Setup Parameters Overview

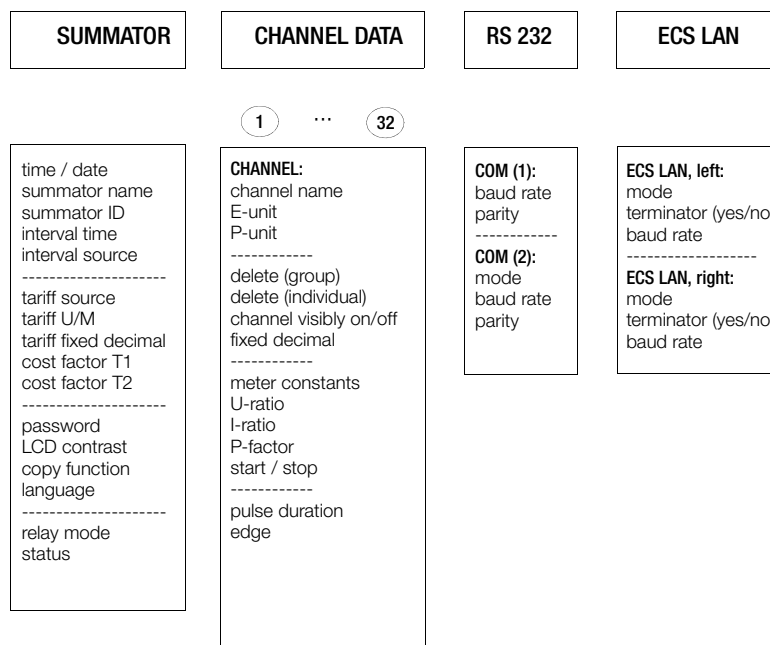

Figure 4, Setup Parameters

U1600

ECS ENERGY • CONTROL • SYSTEM

Network Setup (ECS LAN)

ECS LAN network topology can be freely selected and can thus be individually adapted to existing lines of communication at the installation site.

A network encompasses a maximum of 255 stations, each of which functions as a router and a repeater thanks to the two integrated ECS LAN interfaces. Individual messages are thus only forwarded if the receiver is located within the respective bus segment. Transmission distances are measured from device to device if a line-to-line structure is used.

Cable Lengths

The allowable distance between two summators with 2-wire connection is 400 m, and 1.2 km with 4-wire connection. Alternatively, a 2-wire bus system of up to 100 m with a maximum of 16 users can also be implemented. Wiring is accomplished with a twisted pair cable (0.6 ... 0.8 mm diameter).

Distances of greater than 1.2 km are made possible with RS 485 boosters or fiber optic cable. Remote data transmission is accomplished with a modem via public telephone lines.

Detailed wiring instructions are included in the operating instructions.

Technical Data, ECS LAN

Bus Type	LAN (local area network), RS 485 electrical interface
Data Protocol	HDLC/SDLC adapted to multi-master requirements
Bus Topology	line, open ring, line and open ring (may be mixed as desired)
Allowable Cable Lengths	1200 m for open ring, 100 m for bus operation
Transmission Speed	62.5 kBit/s or 125 kBit/s
Transmission Reliability	hamming distance $d = 4$
Bus Function Status Display	LED

Office Building (A: Plant 1)

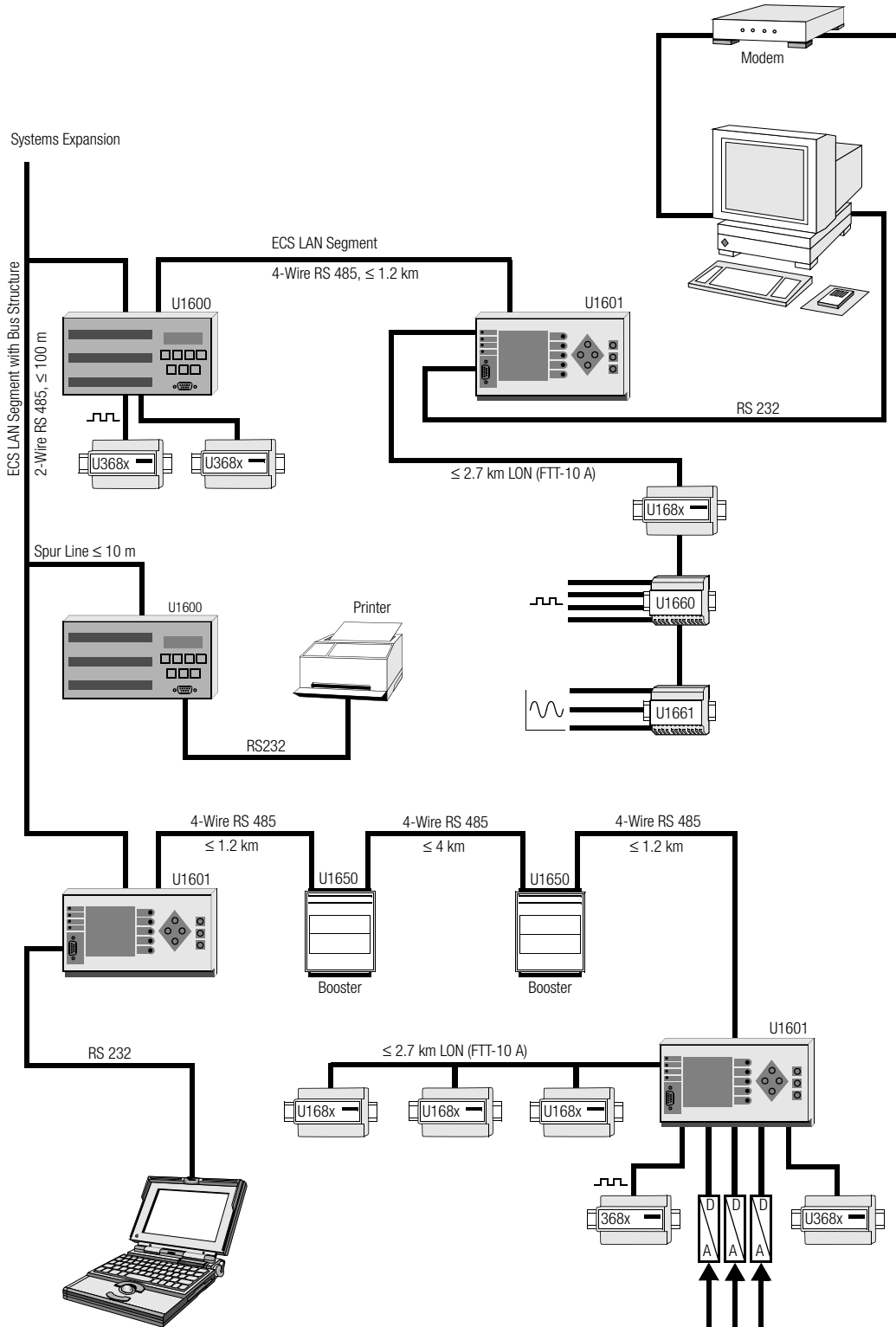

Factory (B: Plant 2)

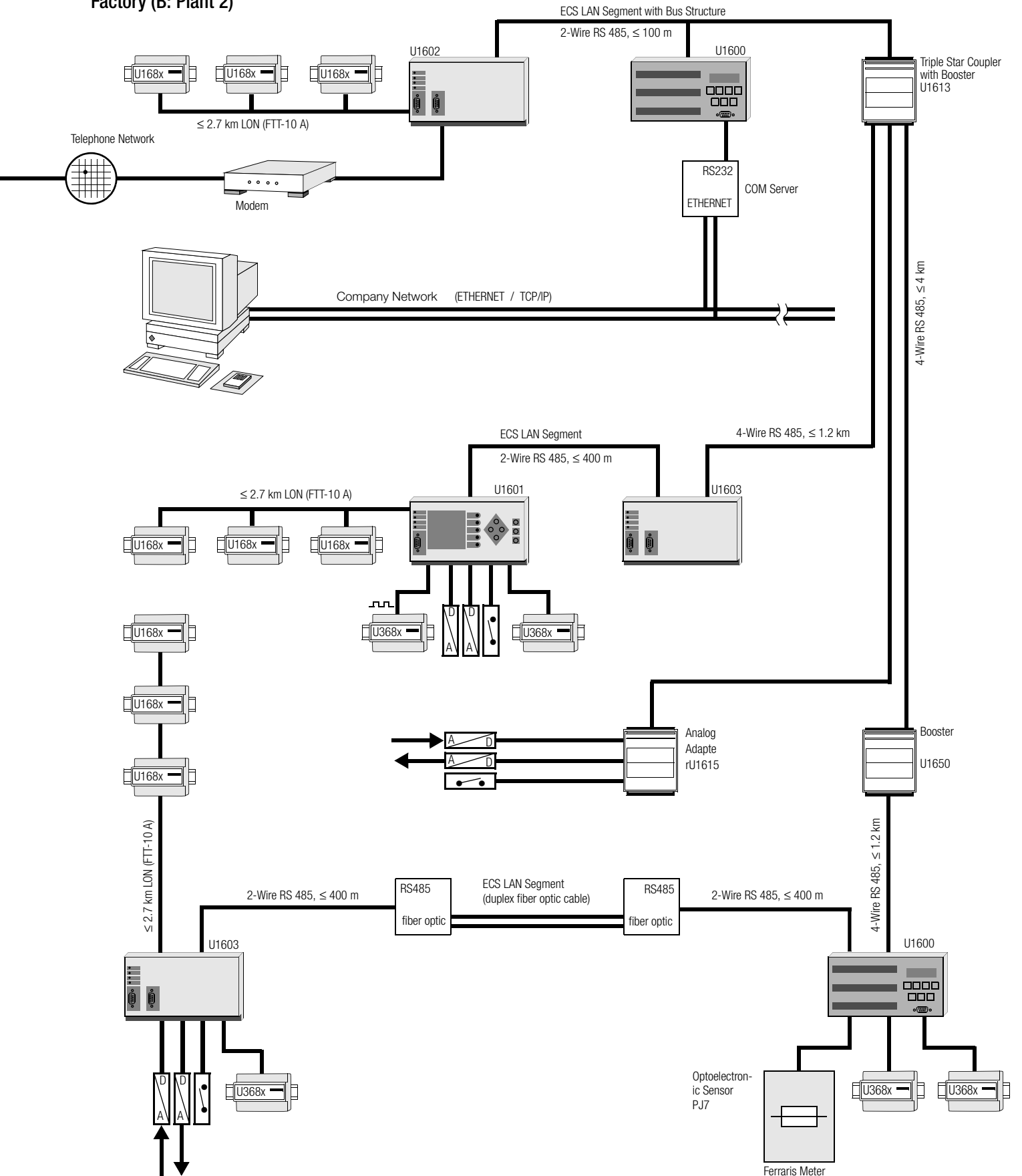

U1600

ECS ENERGY • CONTROL • SYSTEM

Order Information

- The following applies to the selection of order numbers:
- Only one designation with the same given letter may be selected.
 - If the upper case letter in the designation is followed by zeros only, the designation need not be included in the order.

Description		Designation				
U1600 Summator	with bus connection, serial interface and 24 meter inputs	GTU1600				
Auxiliary Voltage	AC + DC nominal range of use: 80 V ... 250 V DC nominal range of use: 20 V ... 80 V	H1 H2				
Language for Menus	German English	S1 S2				
Additional Text on Serial Pate	with without	Z1 Z0				
Expanded Memory	with without	E1 E0				

Order Example

Either the description or the designation can be entered to the order.

Description (enter in clear text)		Designation				
U1600 Summator	with bus connection, serial interface and 24 meter inputs	GTU1600				
Auxiliary Voltage	DC nominal range of use: 20 V ... 80 V	H2				
Language for Menus	German	S1				

Accessories

Description		Designation				
Connector Cable	for PC or terminal	GTZ5232000R0001				

По вопросам продажи и поддержки обращайтесь:

Архангельск (8182)63-90-72
Астана (7172)727-132
Астрахань (8512)99-46-04
Барнаул (3852)73-04-60
Белгород (4722)40-23-64
Брянск (4832)59-03-52
Владивосток (423)249-28-31
Волгоград (844)278-03-48
Вологда (8172)26-41-59
Воронеж (473)204-51-73
Екатеринбург (343)384-55-89
Иваново (4932)77-34-06
Ижевск (3412)26-03-58
Казань (843)206-01-48

Калининград (4012)72-03-81
Калуга (4842)92-23-67
Кемерово (3842)65-04-62
Киров (8332)68-02-04
Краснодар (861)203-40-90
Красноярск (391)204-63-61
Курск (4712)77-13-04
Липецк (4742)52-20-81
Магнитогорск (3519)55-03-13
Москва (495)268-04-70
Мурманск (8152)59-64-93
Набережные Челны (8552)20-53-41
Нижний Новгород (831)429-08-12
Новокузнецк (3843)20-46-81

Новосибирск (383)227-86-73
Омск (3812)21-46-40
Орел (4862)44-53-42
Оренбург (3532)37-68-04
Пенза (8412)22-31-16
Пермь (342)205-81-47
Ростов-на-Дону (863)308-18-15
Рязань (4912)46-61-64
Самара (846)206-03-16
Санкт-Петербург (812)309-46-40
Саратов (845)249-38-78
Севастополь (8692)22-31-93
Симферополь (3652)67-13-56
Смоленск (4812)29-41-54

Сочи (862)225-72-31
Ставрополь (8652)20-65-13
Сургут (3462)77-98-35
Тверь (4822)63-31-35
Томск (3822)98-41-53
Тула (4872)74-02-29
Тюмень (3452)66-21-18
Ульяновск (8422)24-23-59
Уфа (347)229-48-12
Хабаровск (4212)92-98-04
Челябинск (351)202-03-61
Череповец (8202)49-02-64
Ярославль (4852)69-52-93

Единый адрес для всех регионов: cmn@nt-rt.ru || www.camille-bauer.nt-rt.ru

PROCESS CONTROL ENGINEERING



ANGULAR POSITION ENGINEERING

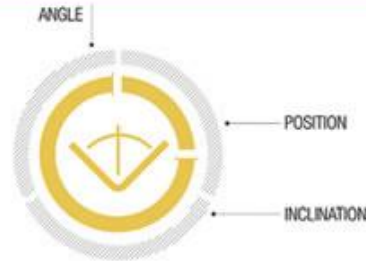

HEAVY CURRENT ENGINEERING

