



Преобразователь температуры SINEAX V611

Архангельск (8182)63-90-72
Астана (7172)727-132
Астрахань (8512)99-46-04
Барнаул (3852)73-04-60
Белгород (4722)40-23-64
Брянск (4832)59-03-52
Владивосток (423)249-28-31
Волгоград (844)278-03-48
Вологда (8172)26-41-59
Воронеж (473)204-51-73
Екатеринбург (343)384-55-89
Иваново (4932)77-34-06
Ижевск (3412)26-03-58
Казань (843)206-01-48

Калининград (4012)72-03-81
Калуга (4842)92-23-67
Кемерово (3842)65-04-62
Киров (8332)68-02-04
Краснодар (861)203-40-90
Красноярск (391)204-63-61
Курск (4712)77-13-04
Липецк (4742)52-20-81
Магнитогорск (3519)55-03-13
Москва (495)268-04-70
Мурманск (8152)59-64-93
Набережные Челны (8552)20-53-41
Нижний Новгород (831)429-08-12
Новокузнецк (3843)20-46-81

Новосибирск (383)227-86-73
Омск (3812)21-46-40
Орел (4862)44-53-42
Оренбург (3532)37-68-04
Пенза (8412)22-31-16
Пермь (342)205-81-47
Ростов-на-Дону (863)308-18-15
Рязань (4912)46-61-64
Самара (846)206-03-16
Санкт-Петербург (812)309-46-40
Саратов (845)249-38-78
Севастополь (8692)22-31-93
Симферополь (3652)67-13-56
Смоленск (4812)29-41-54

Сочи (862)225-72-31
Ставрополь (8652)20-65-13
Сургут (3462)77-98-35
Тверь (4822)63-31-35
Томск (3822)98-41-53
Тула (4872)74-02-29
Тюмень (3452)66-21-18
Ульяновск (8422)24-23-59
Уфа (347)229-48-12
Хабаровск (4212)92-98-04
Челябинск (351)202-03-61
Череповец (8202)49-02-64
Ярославль (4852)69-52-93

Единый адрес для всех регионов: cmn@nt-rt.ru || www.camille-bauer.nt-rt.ru

использовано с разрешения официального
дистрибьютора АО «ЮЕ-Интернейшнл»

SINEAX V 611

Programmable Temperature Transmitter

**Two-wire,
for RTD and TC inputs,
for rail mounting in housing K7**

Application

SINEAX V 611 is a two-wire transmitter. It is designed for **measuring temperature in combination with thermocouples or resistance thermometers**. Thermocouple non-linearities are automatically compensated. The output signal is a current in the range 4...20 mA.

The input variable and measuring range are programmed with the aid of a PC and the corresponding software.

The sensor circuit is monitored for open and short-circuits and the output responds in a defined manner if one is detected.

The power supply (12...30 V DC) is connected together with the signal by the two leads connected to the measurement output (loop powered).



Fig. 1. Measuring transmitter SINEAX V 611 in housing K7 clipped onto a top-hat rail.

Features / Benefits

- **Input variable and measuring range programmed using PC / Simplifies project planning and engineering, short delivery times, low stocking levels**

Measured variables	Measuring ranges		
	Limits	Min. span	Max. span
Temperatures with resistance thermometers for two, three or four-wire connection Pt 100, IEC 60 751 Ni 100, DIN 43 760	- 200 to 850 °C - 60 to 250 °C	50 K 50 K	850 K 250 K
Temperatures with thermocouples Type B, E, J, K, N, R, S, T acc. to IEC 60 584-1 Type L and U, DIN 43 710 Type W5 Re/W26 Re, Type W3 Re/W25 Re acc. to ASTM E 988-90	acc. to type	2 mV	80 mV

- **Two-wire transmitter for installation in the process environment**
- **Open and short-circuit sensor circuit supervision / Defined output response should the supervision pick up**
- **Programmable with or without power supply connection**
- **Compact design (housing only 7 mm wide) / Makes maximum use of available space**

Standard versions

The following version is available as standard version already programmed for the **basic** configuration. It is only necessary to quote the **Order No.:**

Table 1:

Version	Order Code	Order No
Standard, not electrically isolated, cold junction compensation incorporated	611-K0	152 504

Basic configuration: Measuring input: Pt 100 for **three-wire** connection
 Measuring range: 0 ... 600 °C
 Measuring output: 4 ... 20 mA, linearised with temperature
 Open-circuit supervision: Output 21.6 mA
 Response time: Approx. 2 s (Table 2)
 Mains ripple suppression: For frequency 50 Hz

Please complete the Order Code 611-K1.. according to "Table 3: Specification and ordering information" for versions with user-specific input ranges.

SINEAX V 611

Programmable Temperature Transmitter

Programming

A PC, the programming cable PK 610 plus ancillary cable and the programming software V 600 *plus* are required to program the transmitter. (Details of the programming cable and the software are to be found in the separate data sheet: PK 610 Le.)

The connections between "PC ↔ PK 610 ↔ SINEAX V 611" can be seen from Fig. 2. The transmitter can be programmed either with or without the power supply connected.

The software V 600 *plus* is supplied on one CD and runs under Windows 95/NT or higher.

The programming cable PK 610 adjusts the signal level between the PC and the transmitter SINEAX V 611.

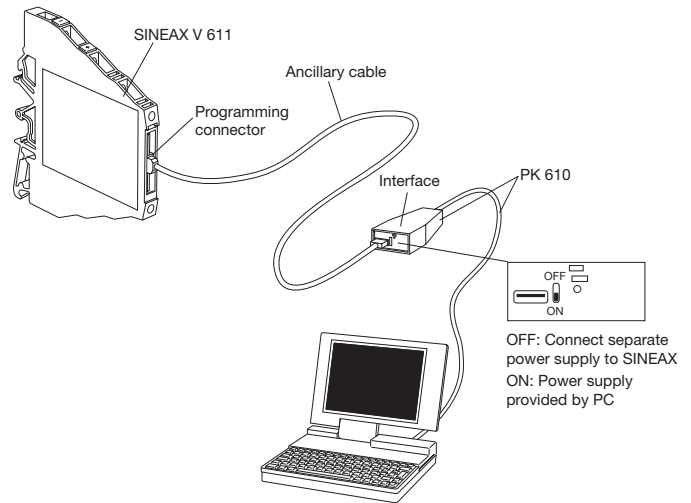

Fig. 2. Example of the set-up for programming a SINEAX V 611 without the power supply. For this case the switch on the interface must be set to "ON".

Technical data

Measuring input \rightarrow

Temperature with resistance thermometers

Resistance types:	Type Pt 100 (IEC 60 751) Type Ni 100 (DIN 43 760) other sensor types configurables
Measuring current:	≤ 0.20 mA
Standard circuit:	1 resistance thermometer for two, three or four -wire connection
Input resistance:	$R_i > 10$ M Ω
Lead resistance:	≤ 30 Ω per lead

Temperature with thermocouple

Thermocouple pairs:	Type B: Pt30Rh-Pt6Rh (IEC 584) Type E: NiCr-CuNi (IEC 584) Type J: Fe-CuNi (IEC 584) Type K: NiCr-Ni (IEC 584) Type L: Fe-CuNi (DIN 43710) Type N: NiCrSi-NiSi (IEC 584) Type R: Pt13Rh-Pt (IEC 584) Type S: Pt10Rh-Pt (IEC 584) Type T: Cu-CuNi (IEC 584) Type U: Cu-CuNi (DIN 43710) Type W5 Re/W26 Re (ASTM) Type W3 Re/W25 Re (E 988-90)
Standard circuit:	1 thermocouple, internal cold junction compensation with built-in Pt 100 or 1 thermocouple, external cold junction compensation
Input resistance:	$R_i > 10$ M Ω

Cold junction compensation:

Internal:	Internal or external With built-in Pt 100 or with Pt 100 connected to the terminals
External:	Via cold junction thermostat 0 ... 60 °C, configurable

Measuring output \rightarrow

Output signal I_A :	(output/powering circuit) Impressed DC current, linear with temperature
Standard range:	4...20 mA, 2-wire technique
External resistance (load):	$R_{ext} \text{ max.} = \frac{\text{Power supply [V]} - 12 \text{ V}}{\text{Max. output current [mA]}}$ [k Ω]

Load max. [Ω] with 20 mA output

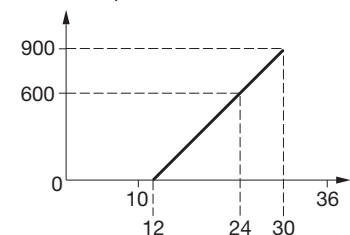

Residual ripple in output current:	< 1% p.p.
------------------------------------	-----------

SINEAX V 611

Programmable Temperature Transmitter

Table 2: Response time

Measuring mode	Open sensor circuit	Short-circuit	Possible response times approx. [s]							
			Option							
TC int. comp.	active	–	1.5	2.5	3.5	6.5	11	20.5	40	
TC int. comp.	off	–	1.5	2.5	3.5	6.5	13.5	24.5	49.5	
TC ext. comp.	active	–	1.5	2.5	3.5	6.5	11	20.5	40	
TC ext. comp.	off	–	1.5	2.5	4	6.5	13.5	24.5	48.5	
RTD 2L	active	–	2	2.5	3	5	9.5	17.5	33.5	
RTD 3L, 4L	active	active	2	2.5	4	6.5	11.5	21	40.5	
RTD 2L,3L,4L	off	off	1.5	2.5	3.5	7.5	14	26.5	50.5	

*) Standard values, also valid for basic configuration

Programming connector

Interface: Serial interface

Accuracy data (acc. to EN/IEC 60 770-1)

Reference value: Measuring span

Basic accuracy: Error limits $\leq \pm 0.2\%$ at reference conditions

Reference conditions

Ambient temperature 23 °C

Power supply 18 V DC

Output burden 250 Ω

Settings Pt100, 3-wire, 0...600 °C

Additional errors (additive)

Low measuring ranges

Voltage measurement $\pm 5 \mu\text{V}$ at measuring spans < 10 mV

Resistance thermometer $\pm 0.3 \text{ K}$ at measuring spans < 400 °C

Thermocouple

Type U, T, L, J, K, E $\pm 0.1 \text{ K}$ at measuring spans < 200 °C

Type N $\pm 0.13 \text{ K}$ at meas. spans < 320 °C

Type S, R $\pm 0.42 \text{ K}$ at meas. spans < 1000 °C

Type B $\pm 0.6 \text{ K}$ at meas. spans < 1400 °C

High initial value (Additional error = Factor · Initial value)

Factor

Voltage measurement $\pm 0.1 \mu\text{V} / \text{mV}$

Resistance thermometer $\pm 0.00075 \text{ K} / ^\circ\text{C}$

Thermocouple

Type U, T, L, J, K, E $\pm 0.0006 \text{ K} / ^\circ\text{C}$

Type N $\pm 0.0008 \text{ K} / ^\circ\text{C}$

Type S, R $\pm 0.0025 \text{ K} / ^\circ\text{C}$

Type B $\pm 0.0036 \text{ K} / ^\circ\text{C}$

Influence of lead resistance

at resistance thermometer $\pm 0.01\%$ per Ω

Internal cold junction

compensation $\pm 0.5 \text{ K}$

Linearisation $\pm 0.3\%$

Influencing factors

Temperature $\leq \pm (0.15\% + 0.15 \text{ K})$ per 10 K with temperature measurement

$\leq \pm (0.15\% + 12 \mu\text{V})$ per 10 K with voltage measurement

Power supply influence (power supply on terminals) $\leq \pm 0.005\%$ per V

Long-time drift $\leq \pm 0.1\%$

Common and transverse mode influence $\leq \pm 0.2\%$

Open and short-circuit sensor circuit supervision

Signalling modes: Output signal programmable to ...
 ... the value the output had immediately prior to the open or short-circuit (hold value)
 ... a value between 4 and 21.6 mA

Power supply $\rightarrow \bigcirc$

DC voltage: Supply 12...30 V DC
 max. residual ripple 1% p.p.
 (supply must not fall below 12 V)
 Protected against wrong polarity

Installation data

Housing: Housing K7 for rail mounting
 Dimensions see section "Dimensional drawings"

Material of housing: Polyamide
 Flammability Class V2 acc. to UL 94, self-extinguishing, non-dripping, free of halogen

Mounting: For snapping
 – onto rail G acc. to EN 50 035 – G32
 or
 – onto top-hat rail acc. to EN 50 022 (35 x 15 mm or 35 x 7.5 mm)

Standards

Electromagnetic compatibility: The standards EN 50 081-2 and EN 50 082-2 are observed

Protection (acc. to IEC 529 resp. EN 60 529): Housing IP 40
 Terminals IP 20

Electrical standards: Acc. to IEC 1010 resp. EN 61 010

SINEAX V 611

Programmable Temperature Transmitter

Ambient conditions

Climatic rating: IEC 60 068-2-1/2/3

Ambient temperature range: - 25 to + 55 °C

Storage temperature range:

- 40 to + 80 °C

Annual mean relative humidity:

≤ 75%, no moisture condensation

Table 3: Specification and ordering information (see also Table 1: Standard versions)

Order Code 611 -				
Features, Selection	*SCODE	no-go		
1. Housing K) SINEAX in housing K7				
2. Configuration 0) Basic configuration programmed, (Pt 100, three-wire, 0 to 600 °C, 4 to 20 mA) 1) Configured to order Features 3 to 9 may only be given if "configured to order" (selection 1) is specified	G		. 0 1	
3. Measuring mode, input connection Thermocouple, linearised 1) Internal cold junction compensation, with built-in Pt 100 2) External cold junction compensation t_k [°C] 	T	G	. . 1 2	
Resistance thermometer, linearised 3) Two-wire connection, R_L [Ω] 4) Three-wire connection 5) Four-wire connection	R	G	. . 3 4 5	
Line 2: External cold junction temperature t_k between 0 and 60 °C Line 3: Total lead resistance R_L max. 60 Ω				

Table 3: "Specification and ordering information" continued on next page!

SINEAX V 611

Programmable Temperature Transmitter

Order Code 611 -				
Features, Selection	*SCODE	no-go		
4. Sensor type / measuring range beginning value; end value				
Sensor type / measuring range beginning value...end value				
1) Pt 100	Range		GT	1
2) Ni 100	Range		GT	2
3) Pt ... [Ω] (value at 0 °C)	Range		GT	3
4) Ni ... [Ω] (value at 0 °C)	Range		GT	4
B) TC Type B	Range		GR	B
E) TC Type E	Range		GR	E
J) TC Type J	Range		GR	J
K) TC Type K	Range		GR	K
L) TC Type L	Range		GR	L
N) TC Type N	Range		GR	N
R) TC Type R	Range		GR	R
S) TC Type S	Range		GR	S
T) TC Type T	Range		GR	T
U) TC Type U	Range		GR	U
W) TC W5-W26Re	Range		GR	W
X) TC W3-W25Re	Range		GR	X
All temperatures in °C				
5. Output characteristic				
0) Standard 4 to 20 mA			G	. 0
1) Inversely 20 to 4 mA			G	. 1
6. Open and short-circuit sensor signalling				
0) Output 21.6 mA			G	. . 0
1) Output (any value between 4 and < 21.6 mA) [mA]			G	. . 1
2) Hold output at last value			G	. . 2
A) No signal			G	. . A
Short-circuit signaling is only possible for three and four-wire connection resistance thermometers from 100 Ω at 0 °C				
7. Output time response				
1) Setting time 2 s			G	. . . 1
9) Setting time [s]			G	. . . 9
Line 9: Admissible values see Table 2				
8. Mains ripple suppression				
0) For frequency 50 Hz			G 0
1) For frequency 60 Hz			G 1
9. Test certificate				
0) Without test certificate			 0
D) Test certificate in German			G D
E) Test certificate in English			G E

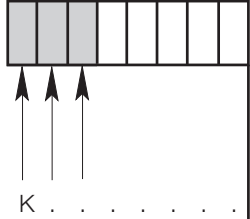
* Lines with letter(s) under "no-go" cannot be combined with preceding lines having the same letter under "SCODE".

SINEAX V 611

Programmable Temperature Transmitter

Electrical connections

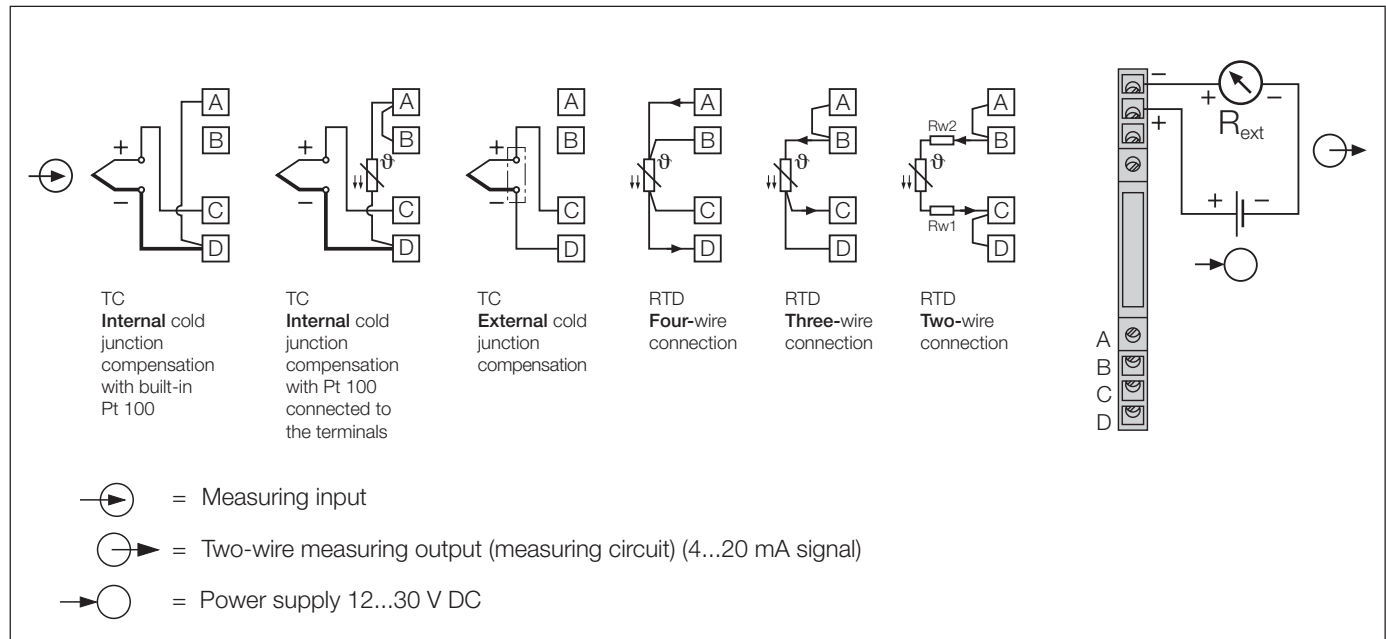

Table 4: Accessories and spare parts

Description	Order No.
Programming cable PK 610 	137 887
Ancillary cable 	141 440
Configuration Software V 600 <i>plus</i> * on CD in German, English, French, Spanish, Italian and Dutch Windows 95 or higher. The CD contains all configuration programmes presently available for Camille Bauer products	146 557
Operating Instructions V 611 Bd in German	152 471
Operating Instructions V 611 Bf in French	152 489
Operating Instructions V 611 Be in English	152 497

Standard accessories

- 1 Operating Instructions in German, French and English

SINEAX V 611

Programmable Temperature Transmitter

Dimensional drawings

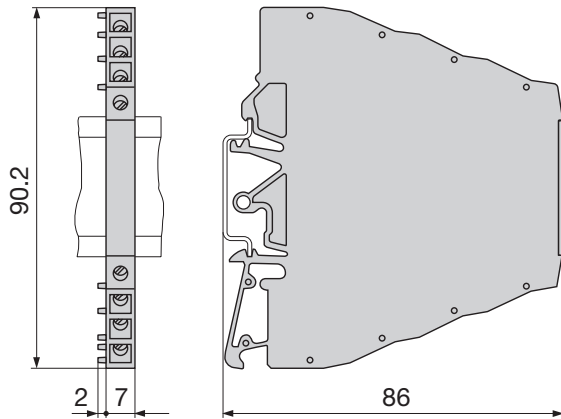

Fig. 3. SINEAX V 611 in housing **K7**
clipped onto a top-hat rail EN 50 022 – 35 x 7.5.

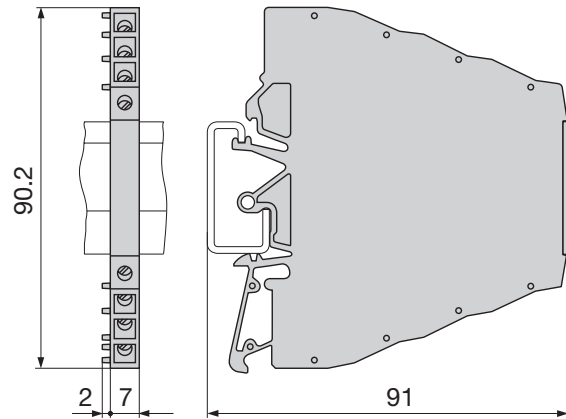

Fig. 4. SINEAX V 611 in housing **K7**
clipped onto a rail "G" EN 50 035 – G32.

По вопросам продажи и поддержки обращайтесь:

Архангельск (8182)63-90-72
Астана (7172)727-132
Астрахань (8512)99-46-04
Барнаул (3852)73-04-60
Белгород (4722)40-23-64
Брянск (4832)59-03-52
Владивосток (423)249-28-31
Волгоград (844)278-03-48
Вологда (8172)26-41-59
Воронеж (473)204-51-73
Екатеринбург (343)384-55-89
Иваново (4932)77-34-06
Ижевск (3412)26-03-58
Казань (843)206-01-48

Калининград (4012)72-03-81
Калуга (4842)92-23-67
Кемерово (3842)65-04-62
Киров (8332)68-02-04
Краснодар (861)203-40-90
Красноярск (391)204-63-61
Курск (4712)77-13-04
Липецк (4742)52-20-81
Магнитогорск (3519)55-03-13
Москва (495)268-04-70
Мурманск (8152)59-64-93
Набережные Челны (8552)20-53-41
Нижний Новгород (831)429-08-12
Новокузнецк (3843)20-46-81

Новосибирск (383)227-86-73
Омск (3812)21-46-40
Орел (4862)44-53-42
Оренбург (3532)37-68-04
Пенза (8412)22-31-16
Пермь (342)205-81-47
Ростов-на-Дону (863)308-18-15
Рязань (4912)46-61-64
Самара (846)206-03-16
Санкт-Петербург (812)309-46-40
Саратов (845)249-38-78
Севастополь (8692)22-31-93
Симферополь (3652)67-13-56
Смоленск (4812)29-41-54

Сочи (862)225-72-31
Ставрополь (8652)20-65-13
Сургут (3462)77-98-35
Тверь (4822)63-31-35
Томск (3822)98-41-53
Тула (4872)74-02-29
Тюмень (3452)66-21-18
Ульяновск (8422)24-23-59
Уфа (347)229-48-12
Хабаровск (4212)92-98-04
Челябинск (351)202-03-61
Череповец (8202)49-02-64
Ярославль (4852)69-52-93

Единый адрес для всех регионов: cmn@nt-rt.ru || www.camille-bauer.nt-rt.ru

PROCESS CONTROL ENGINEERING



ANGULAR POSITION ENGINEERING



HEAVY CURRENT ENGINEERING

