



Преобразователь температуры SINEAX V624

Архангельск (8182)63-90-72
 Астана (7172)727-132
 Астрахань (8512)99-46-04
 Барнаул (3852)73-04-60
 Белгород (4722)40-23-64
 Брянск (4832)59-03-52
 Владивосток (423)249-28-31
 Волгоград (844)278-03-48
 Вологда (8172)26-41-59
 Воронеж (473)204-51-73
 Екатеринбург (343)384-55-89
 Иваново (4932)77-34-06
 Ижевск (3412)26-03-58
 Казань (843)206-01-48

Калининград (4012)72-03-81
 Калуга (4842)92-23-67
 Кемерово (3842)65-04-62
 Киров (8332)68-02-04
 Краснодар (861)203-40-90
 Красноярск (391)204-63-61
 Курск (4712)77-13-04
 Липецк (4742)52-20-81
 Магнитогорск (3519)55-03-13
 Москва (495)268-04-70
 Мурманск (8152)59-64-93
 Набережные Челны (8552)20-53-41
 Нижний Новгород (831)429-08-12
 Новокузнецк (3843)20-46-81

Новосибирск (383)227-86-73
 Омск (3812)21-46-40
 Орел (4862)44-53-42
 Оренбург (3532)37-68-04
 Пенза (8412)22-31-16
 Пермь (342)205-81-47
 Ростов-на-Дону (863)308-18-15
 Рязань (4912)46-61-64
 Самара (846)206-03-16
 Санкт-Петербург (812)309-46-40
 Саратов (845)249-38-78
 Севастополь (8692)22-31-93
 Симферополь (3652)67-13-56
 Смоленск (4812)29-41-54

Сочи (862)225-72-31
 Ставрополь (8652)20-65-13
 Сургут (3462)77-98-35
 Тверь (4822)63-31-35
 Томск (3822)98-41-53
 Тула (4872)74-02-29
 Тюмень (3452)66-21-18
 Ульяновск (8422)24-23-59
 Уфа (347)229-48-12
 Хабаровск (4212)92-98-04
 Челябинск (351)202-03-61
 Череповец (8202)49-02-64
 Ярославль (4852)69-52-93

Единый адрес для всех регионов: cmn@nt-rt.ru || www.camille-bauer.nt-rt.ru

использовано с разрешения официального
 дистрибьютора АО «ЮЕ-Интернейшнл»

SINEAX V624, Programmable Temperature Transmitter for RTD and TC inputs

for rail mounting in housing P12/17 or P12/17 St



II (1) G [Ex ia Ga] IIC
II (1) D [Ex ia Da] IIIC

Application

SINEAX V624 (Fig. 1) is designed for measuring temperature in combination with thermocouples or resistance thermometers. Thermocouple non-linearities are automatically compensated.

The analog output signal is either an impressed current or superimposed voltage which is linearly proportional to temperature and can be processed by other devices for purposes of displaying, recording and/or regulating a constant.

The input variable and measuring range are programmed with the aid of a PC and the corresponding software.

The sensor circuit is monitored for open and short-circuits and the output responds in a defined manner if one is detected.

The transmitter fulfils all the important requirements and regulations concerning electromagnetic compatibility **EMC** and **Safety** (EN 61010). It was developed and is manufactured and tested in strict accordance with the **quality assurance standard** ISO 9001.

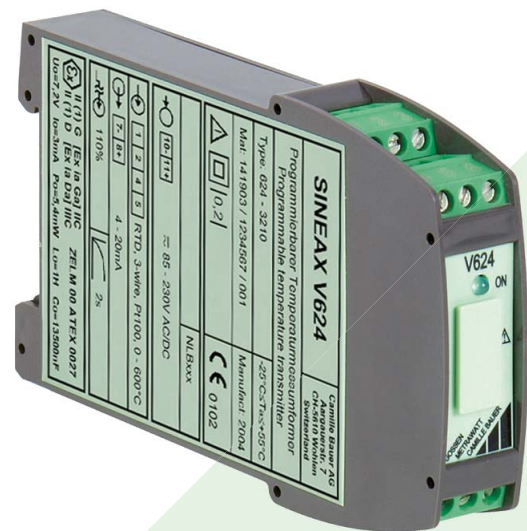

Fig. 1. Transmitter SINEAX V624 in housing P12/17, terminals not pluggable.

Features / Benefits

- Input variable and measuring range programmed using PC / Simplifies project planning and engineering, short delivery times, low stocking levels

Measured variables	Measuring ranges		
	Limits	Min. span	Max. span
Temperatures with resistance thermometers for two, three or four -wire connection			
Pt100, IEC 60751	- 200 to 850 °C	50 K	850 K
Ni100, DIN 43760	- 60 to 250 °C	50 K	250 K
Temperatures with thermocouples			
Type B, E, J, K, N, R, S, T acc. to IEC 60584-1	acc. to type	2 mV	80 mV
Type L and U, DIN 43710			
Type W5 Re/W26 Re Type W3 Re/W25 Re acc. to ASTM E 988-90			

- Electric isolation between input, output 2.3 kV and power supply 3.7 kV / Fulfils EN 61010
- Wide DC, AC power pack tolerance / Universal

- Available in type of protection "Intrinsic safety" [Ex ia Ga] IIC and [Ex ia Da] IIIC (see "Table 3: Data on explosion protection")
- Ex devices also directly programmable on site / No supplementary Ex interface needed
- Open and short-circuit sensor circuit supervision / Defined output response should the supervision pick up
- Programmable with or without power supply connection
- Housing only 17.5 mm wide (size P12/17 housing) / Low space requirement
- Other programmable parameters: specific measured variable data (e.g. two, three or four-wire connection for resistance thermometers, "internal" or "external" cold junction compensation of thermocouples etc.), **transmission mode, operating sense** (output signal directly or inversely proportional to the measured variable) and **open-circuit sensor supervision** (output signal assumes fixed preset value between -5 and 110%) / **Highly flexible solutions for measurement problems**
- Software calibration of beginning and end of output signal range
- Digital measured variable data available at the programming interface/ Simplifies commissioning, measured variable and signals can be viewed on PC in the field

SINEAX V624, Programmable Temperature Transmitter for RTD and TC inputs

Programming

A PC, the programming cable PK610 plus ancillary cable and the programming software V 600 *plus* are required to program the transmitter. (Details of the programming cable and the software are to be found in the separate data sheet: PK610 Le.)

The connection between "PC ↔ PK610 ↔ SINEAX V624" can be seen from Fig. 2. The transmitter can be programmed either with or without the power supply connected.

The software V 600 *plus* is supplied on one CD and runs under Windows 3.1x or higher.

The programming cable PK610 adjusts the signal level between the PC and the transmitter SINEAX V624.

The programming cable PK610 is used for programming both standard and Ex versions.

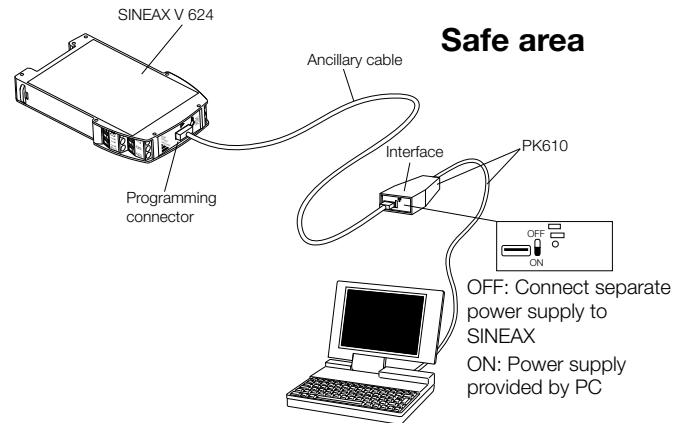

Fig. 2. Example of the set-up for programming a SINEAX V624 in standard version without the power supply. For this case the switch on the interface must be set to "ON".

Technical data

Measuring input →

Temperature with resistance thermometers

Measuring range limits:	See table 7
Resistance types:	Type Pt100 (IEC 60751) Type Ni100 (DIN 43760) Other sensor types configurables
Measuring current:	≤ 0.20 mA
Standard circuit:	1 resistance thermometer for two, three or four -wire connection
Input resistance:	R _i 10 MΩ
Lead resistance:	≤ 30 Ω per lead

Temperature with thermocouple

Measuring range limits:	See table 7
Thermocouple pairs:	Type B: Pt30Rh-Pt6Rh (IEC60584-1) Type E: NiCr-CuNi (IEC60584-1) Type J: Fe-CuNi (IEC60584-1) Type K: NiCr-Ni (IEC60584-1) Type L: Fe-CuNi (DIN43710) Type N: NiCrSi-NiSi (IEC60584-1) Type R: Pt13Rh-Pt (IEC60584-1) Type S: Pt10Rh-Pt (IEC60584-1) Type T: Cu-CuNi (IEC60584-1) Type U: Cu-CuNi (DIN43710) Type W5 Re/W26 Re (ASTM) Type W3 Re/W25 Re (E 988-90)
Standard circuit:	1 thermocouple, internal cold junction compensation with built-in Pt100 or 1 thermocouple, external cold junction compensation
Input resistance:	R _i 10 MΩ

Cold junction compensation:

Internal:	With built-in Pt100 or with Pt100 connected to the terminals
External:	Via cold junction thermostat 0 ... 60 °C, configurable

Measuring output →

DC current*:	Programmable between 0 and 20 resp. 20 and 0 mA minimum span 2 mA
Burden voltage:	12 V
Open-circuit voltage:	< 20 V
External resistance:	$R_{\text{ext max. [k}\Omega]} = \frac{12 \text{ V}}{I_{\text{AN [mA]}}$ I _{AN} = Output current end value
Residual ripple:	1.0% p.p., DC ... 10 kHz
DC voltage*:	Programmable between 0 and 10 resp. 10 and 0 V minimum span 1 V
Short-circuit current:	≤ 50 mA
External resistance:	$R_{\text{ext min. [k}\Omega]} \geq \frac{U_{\text{AN [V]}}}{5 \text{ mA}}$ U _{AN} = Output voltage end value
Residual ripple:	1.0% p.p., DC ... 10 kHz

* The output variable (current or voltage) is not re-programmable!

SINEAX V624, Programmable Temperature Transmitter for RTD and TC inputs

Table 1: Response time

Measuring mode	Open sensor	Short-circuit	Possible response times approx. [s]							
			*)	Option						
TC int. comp.	active	—	1.5	2.5	3.5	6.5	11	20.5	40	
TC int. comp.	off	—	1.5	2.5	3.5	6.5	13.5	24.5	49.5	
TC ext. comp.	active	—	1.5	2.5	3.5	6.5	11	20.5	40	
TC ext. comp.	off	—	1.5	2.5	4	6.5	13.5	24.5	48.5	
RTD 2L	active	—	2	2.5	3	5	9.5	17.5	33.5	
RTD 3L, 4L	active	active	2	2.5	4	6.5	11.5	21	40.5	
RTD 2L,3L,4L	off	off	1.5	2.5	3.5	7.5	14	26.5	50.5	

*) Standard values, also valid for basic configuration

Programming connector

interface: Serial interface

Accuracy data (acc. to EN 60770-1)

Reference value: Measuring span

Basic accuracy: Error limits $\leq \pm 0.2\%$ at reference conditions

Reference conditions

Ambient temperature 23 °C

Power supply 24 V DC $\pm 10\%$ and 230 V AC $\pm 10\%$

Output burden Current 300 Ω
Voltage 4 k Ω

Settings Pt100, 3-wire, 0...600 °C

Additional errors (additive)

Low measuring ranges

Voltage measurement $\pm 5 \mu\text{V}$
at measuring spans $< 10 \text{ mV}$

Resistance thermometer $\pm 0.3 \text{ K}$
at measuring spans $< 400 \text{ }^\circ\text{C}$

Thermocouple

Type U, T, L, J, K, E $\pm 0.1 \text{ K}$
at measuring spans $< 200 \text{ }^\circ\text{C}$

Type N $\pm 0.13 \text{ K}$
at measuring spans $< 320 \text{ }^\circ\text{C}$

Type S, R $\pm 0.42 \text{ K}$
at measuring spans $< 1000 \text{ }^\circ\text{C}$

Type B $\pm 0.6 \text{ K}$
at measuring spans $< 1400 \text{ }^\circ\text{C}$

High initial value (Additional error = Factor · Initial value)

Voltage measurement $\pm 0.1 \mu\text{V} / \text{mV}$

Resistance thermometer $\pm 0.00075 \text{ K} / \text{ }^\circ\text{C}$

Thermocouple

Type U, T, L, J, K, E $\pm 0.0006 \text{ K} / \text{ }^\circ\text{C}$

Type N $\pm 0.0008 \text{ K} / \text{ }^\circ\text{C}$

Type S, R $\pm 0.0025 \text{ K} / \text{ }^\circ\text{C}$

Type B $\pm 0.0036 \text{ K} / \text{ }^\circ\text{C}$

Influence of lead resistance at resistance thermometer $\pm 0.01\%$ per Ω

Internal cold junction compensation $\pm 0.5 \text{ K}$ at 23 °C, $\pm 0.25 \text{ K}/10 \text{ K}$

Linearisation $\pm 0.3\%$

If hardware output end value / output span > 1.25
 $\pm \left(\frac{20 \text{ mA resp. } 10 \text{ V}}{\text{output span}} \cdot 0.07\% \right)$

Example:
Hardware output end value 20 mA
New configuration 14 ... 16 mA
Additional error =

$$\pm \left(\frac{20 \text{ mA}}{2 \text{ mA}} \cdot 0.07\% \right) = 0.7\%$$

Influencing factors

Temperature $\pm (0.15\% + 0.15 \text{ K})$ per 10 K with temperature measurement

$\pm (0.15\% + 12 \mu\text{V})$ per 10 K with voltage measurement

Long-time drift $\pm 0.1\%$

Common and transverse mode influence $\pm 0.2\%$

Open and short-circuit sensor circuit supervision

Signalling modes: Output signal programmable to...
... the value the output had immediately prior to the open or short-circuit (hold value)
... a value between -5 and 110% of the output span

Power supply $\rightarrow \text{O}$

DC, AC power pack (DC or 50 to 400 Hz)

Table 2: Rated voltages and permissible variations

Nominal voltages U_N	Tolerance	Instruments Version
24...60 V DC/AC	DC $-15...+33\%$ AC $\pm 15\%$	Standard (Non-Ex)
85...230 V ¹ DC/AC		
24...60 V DC/AC	DC $-15...+33\%$ AC $\pm 15\%$	Type of protection "Intrinsic safety" [Ex ia Ga] IIC [Ex ia Da] IIIC
85...230 V AC		
85...110 V DC		

Installation data: 1.0 W resp. 2.1 VA

Installation data

Housing: Housing **P12/17** and **P12/17 St**
Dimensions see section "Dimensional drawings"

¹An external supply fuse must be provided for DC supply voltages $> 125 \text{ V}$!

SINEAX V624, Programmable Temperature Transmitter for RTD and TC inputs

Material of housing:	Lexan 940 (polycarbonate) Flammability class V-0 acc. to UL 94, self-extinguishing, non-dripping, free of halogen	Pollution degree:	2
Mounting:	For snapping onto top-hat rail (35 x 15 mm or 35 x 7.5 mm) acc. to EN 50022	Installation category:	III for power supply II for measuring input and measuring output
Mounting position:	Any	Double insulation:	– Power supply versus all circuits – Measuring input versus measuring output
Terminals:	PHOENIX screw terminals with wire guards for 0.14 mm ² to 2.5 mm ²	Test voltage:	Power supply versus: – all 3.7 kV, 50 Hz Measuring input versus: – measuring output 2.3 kV, 50 Hz
Weight:	Approx. 0.1 kg		

Electrical insulation: All circuits (measuring input/measuring output/power supply) are electrically insulated

Standards

Electromagnetic compatibility:	The standards EN 61000-6-4 and EN 61000-6-2 are observed
Intrinsically safe:	Acc. to EN 60079-11, EN 60079-26
Protection (acc. to IEC 529 resp. EN 60529):	Housing IP 40 Terminals IP 20
Electrical standards:	EN 61010
Operating voltages:	300 V between all insulated circuits

Ambient conditions

Climatic rating:	IEC 60068-2-1/2/3
Ambient temperature range:	– 25 to + 55 °C
Storage temperature range:	– 40 to + 70 °C
Annual mean relative humidity:	≤ 75%, no moisture condensation
Altitude:	2000 m max.
Indoor use statement!	

Table 3: Data on explosion protection  **II (1) Ga** and  **II (1) Da**

Order Code	Type of protection "Intrinsic safety" Marking		Certificate	Mounting location of instruments
	Instrument	Measuring input		
624-33/34/93/94	[Ex ia Da] IIC [Ex ia Ga] IIIC	[Ex ia Da] IIC [Ex ia Ga] IIIC	EC-type-examination Certificate ZELM 00 ATEX 0027	Outside the hazardous area

Standard versions

The following versions are available as standard versions already programmed for the **basic** configuration. It is only necessary to quote the **Order No.:**

Table 4: Instruments in standard (non-Ex) version (measuring circuit not intrinsically safe)

Measuring input programmable for RTD and TC inputs	Measuring output*	Power supply	Connecting screw terminals	Order Code	Order No.
RTD: Pt100, Ni 100 TC: Types B, E, J, K, L, N, R, S, T and U W5/W26 Re W3/W25 Re	4 ... 20 mA programmable between 0 and 20 resp. 20 and 0 mA minimum span 2 mA	24 ... 60 V DC/AC	not pluggable	624 – 3110	141 896
		85 ... 230 V DC/AC		624 – 3210	141 903
		24 ... 60 V DC/AC	pluggable	624 – 9110	143 412
		85 ... 230 V DC/AC		624 – 9210	143 420

* The output variable (current or voltage) is not re-programmable!

SINEAX V624, Programmable Temperature Transmitter for RTD and TC inputs

Table 5: instruments in [Ex ia Ga] IIC and [Ex ia Da] IIIC version (measuring circuit intrinsically safe)

Measuring input programmable for RTD and TC inputs	Measuring output*	Power supply	Connecting screw terminals	Order Code	Order No.
RTD: Pt100, Ni 100 TC: Types B, E, J, K, L, N, R, S, T and U W5/W26 Re W3/W25 Re	4 ... 20 mA programmable between 0 and 20 resp. 20 and 0 mA minimum span 2 mA	24 ... 60 V DC/AC	not pluggable	624 – 3310	141 911
		85 ... 110 V DC 85 ... 230 V AC		624 – 3410	141 929
		24 ... 60 V DC/AC	pluggable	624 – 9310	143 438
		85 ... 110 V DC/ 85 ... 230 V AC		624 – 9410	143 446

* The output variable (current or voltage) is not re-programmed!

Basic configuration:	Measuring input:	Resistance thermometer Pt100
	Connection mode:	Three-wire connection
	Measuring range:	0 ... 600 °C
	Measuring output:	4 ... 20 mA
	Open-circuit supervision:	Output 21.6 mA
	Response time:	Approx. 1.5/2 s (table 1)
	Mains ripple suppression:	For frequency 50 Hz

Table 6: Specification and ordering information (see also Tables 4 and 5: Standard versions)

Description	*Blocking code	no-go with blocking code	Article No./ Feature
SINEAX V624			624 –
Order Code V624 - xxxx xxxx xxxx			
Features, Selection			
1. Housing			
Housing P12/17 for rail mounting, connecting screw terminals not pluggable			3
Housing P12/17 St for rail mounting, connecting screw terminals pluggable			9
2. Version / Power supply			
Standard / 24 ... 60 V DC/AC			1
Standard / 85 ... 230 V DC/AC			2
[Ex ia Ga] IIC and [Ex ia Da] IIIC / 24 ... 60 V DC/AC			3
[Ex ia Ga] IIC and [Ex ia Da] IIIC / 85 ... 110 V DC / 230 V AC			4
3. Output variable			
Current, end value max. 20 mA			1
Voltage, end value max. 10 V			2
4. Configuration			
Basic configuration programmed (Pt100, three-wire, 0 ... 600 °C) All types with basic configuration are available as standard versions, see table 4 and 5, specification complete!	G		0
Configured to order The following features 5 to 12 must be fully specified!			1
5. Measuring unit			
Temperatures in °C			1
Temperatures in °F		G	2
Temperatures in K		G	3

SINEAX V624, Programmable Temperature Transmitter for RTD and TC inputs

Description	*Blocking code	no-go with blocking code	Article No./ Feature
SINEAX V624 Order Code V624 - xxxx xxxx xxxx			624 -
Features, Selection			
6. Measuring mode, input connection			
Thermocouple			
Internal cold junction compensation, with built-in Pt100	T	G	1
External cold junction compensation t_K <input type="text"/>	T	G	2
Specify external cold junction temperature t_K (in °C, °F or K, acc. to specification in Feature 5), any value between 0 and 60 °C or equivalent			
Resistance thermometer			
Two-wire connection, R_L [Ω] <input type="text"/>	R	G	3
Specify total lead resistance R_L [Ω], any value between 0 and 60 Ω			
Three-wire connection, $R_L \leq 30 \Omega$ /wire	R		4
Four-wire connection, $R_L \leq 30 \Omega$ /wire	R	G	5
7. Sensor type / measuring range			
Sensor type / beginning ... end value of measuring range			
RTD Pt100 Range <input type="text"/>		T	1
RTD Ni 100 Range <input type="text"/>		GT	2
RTD Pt ... [Ω] Range <input type="text"/>		GT	3
RTD Ni ... [Ω] Range <input type="text"/>		GT	4
TC Type B Range <input type="text"/>		GR	B
TC Type E Range <input type="text"/>		GR	E
TC Type J Range <input type="text"/>		GR	J
TC Type K Range <input type="text"/>		GR	K
TC Type L Range <input type="text"/>		GR	L
TC Type N Range <input type="text"/>		GR	N
TC Typ R Range <input type="text"/>		GR	R
TC Typ S Range <input type="text"/>		GR	S
TC Type T Range <input type="text"/>		GR	T
TC Type U Range <input type="text"/>		GR	U
TC W5-W26Re Range <input type="text"/>		GR	W
TC W3-W25Re Range <input type="text"/>		GR	X
Specify measuring range in [°C], [°F] or [K]; refer to table 7 for the operating limits for each type of sensors. Lines 3 and 4: Specify resistance in Ω at 0 °C, any value between 50 and 1000 Ω			
8. Output characteristic			
20 ... 100% end value			0
0 ... 100% end value		G	1
Inversely 100 ... 20% end value		G	2
Inversely 100 ... 0% end value		G	3

SINEAX V624, Programmable Temperature Transmitter for RTD and TC inputs

Description	*Blocking code	no-go with blocking code	Article No./ Feature
SINEAX V624 Order Code V624 - xxxx xxxx xxxx			624 –
Features, Selection			
9. Open and short-circuit sensor signalling			
Output response for an open or short-circuit* sensor			0
Output → at start value + 110% of the span			
Output [%] <input type="text"/>		G	1
Any value from – 5 to < 110; specify value in % of output signal span, e.g. correspondence with output 4 ... 20 or 20 ... 4 mA; – 5% = 3.2 mA and 110% = 21.6 mA			
Hold output at last value		G	2
No signal		G	A
* The short-circuit signal is only active for the RTD measuring mode ≥ 100 Ω at 0 °C and three or four-wire connection			
10. Output time response			
Standard setting time, approx. 2 s			0
Setting time (admissible values see Table 1) [s] <input type="text"/>		G	9
11. Mains ripple suppression			
Frequency 50 Hz			0
Frequency 60 Hz		G	1
12. Test certificate			
Without test certificate			0
Test certificate in German		G	D
Test certificate in English		G	E

* Lines with letter(s) under "Blocking code" cannot be combined with preceding lines having the same letter under "no-go".

Table 7: Measuring range limits

Resistance thermometers		Thermocouple											
Pt100	Ni100	B	E	J	K	L	N	R	S	T	U	C ¹⁾	D ²⁾
– 200 to 850	– 60 to 250	0 to 1820	– 270 to 1000	– 210 to 1200	– 270 to 1372	– 200 to 900	– 270 to 1300	– 50 to 1769	– 50 to 1769	– 270 to 400	– 200 to 600	0 to 2315	0 to 2315
ΔR min. 15 Ω at final value ³⁾ ≤ 400 Ω ΔR min. 150 Ω at final value > 400 Ω max. final value 4000 Ω $\frac{\text{Initial value}}{\Delta R} \leq 10$		ΔU min. 2 mV, max. 80 mV $\frac{\text{Initial value}}{\Delta U} \leq 10$											

¹⁾ W5 Re W26 Re (ASTM E 988-90)

²⁾ W3 Re W25 Re (ASTM E 988-90)

³⁾ For two-wire connection, the final value is made up of the measured final value [Ω] plus the total resistance of the leads.

SINEAX V624, Programmable Temperature Transmitter for RTD and TC inputs

Electrical connections

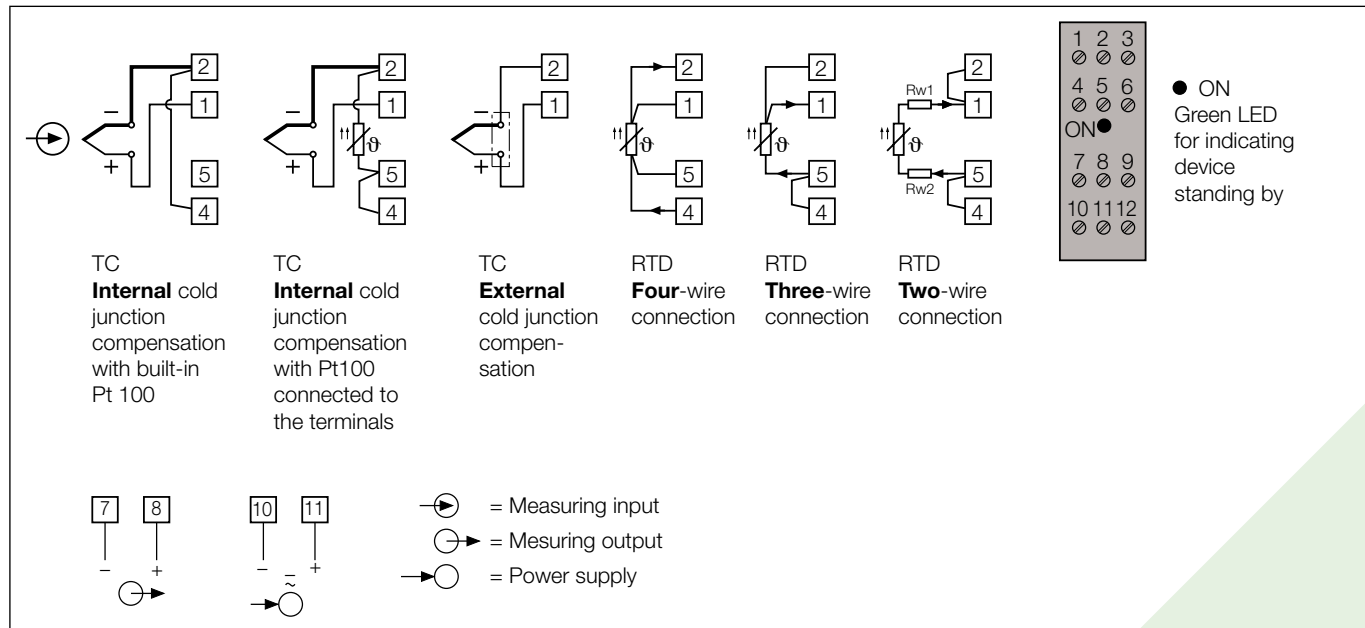
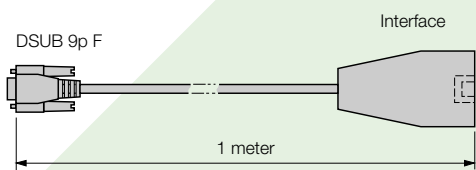
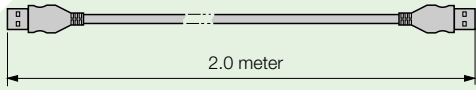

Table 8: Accessories and spare parts

Description	Order No.
Programming cable PK610 	137 887
Ancillary cable SINEAX Type V624 	141 416
Configuration Software V 600 <i>plus</i> for SINEAX V608, VK616 and V624 Windows 3.1x or higher on CD in German, English, French, Spanish, Italian and Dutch In addition, the CD contains all configuration programmes presently available for Camille Bauer products	146 557
Operating Instructions V624 Bd in German	141 995
Operating Instructions V624 Bf in French	142 109
Operating Instructions V624 Be in English	142 159

Standard accessories

- 1 Operating Instructions in German, French and English
- 1 Type examination certificate (only for "Intrinsically safe" explosion-proof devices)

SINEAX V624, Programmable Temperature Transmitter for RTD and TC inputs

Dimensional drawings

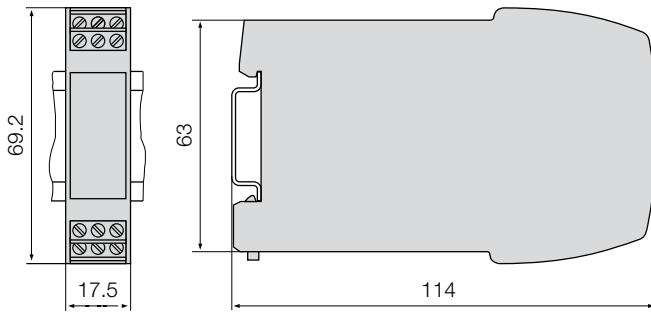

Fig. 3. SINEAX V624 in housing **P12/17** clipped onto a top-hat rail (35 x 15 mm or 35 x 7.5 mm, acc. to EN 50022), connecting screw terminals not pluggable.

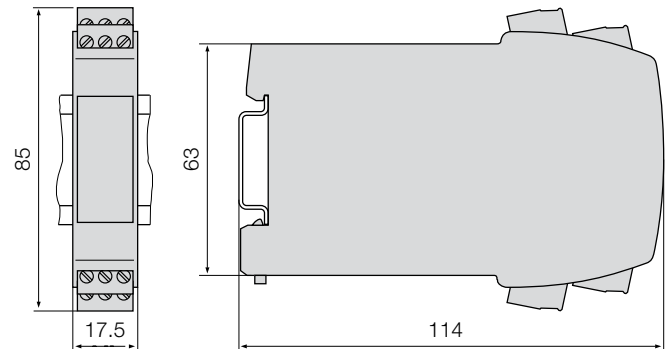

Fig. 4. SINEAX V624 in housing **P12/17 St** clipped onto a top-hat rail (35 x 15 mm or 35 x 7.5 mm, acc. to EN 50022), connecting screw terminals pluggable.

По вопросам продажи и поддержки обращайтесь:

Архангельск (8182)63-90-72
Астана (7172)727-132
Астрахань (8512)99-46-04
Барнаул (3852)73-04-60
Белгород (4722)40-23-64
Брянск (4832)59-03-52
Владивосток (423)249-28-31
Волгоград (844)278-03-48
Вологда (8172)26-41-59
Воронеж (473)204-51-73
Екатеринбург (343)384-55-89
Иваново (4932)77-34-06
Ижевск (3412)26-03-58
Казань (843)206-01-48



Калининград (4012)72-03-81
Калуга (4842)92-23-67
Кемерово (3842)65-04-62
Киров (8332)68-02-04
Краснодар (861)203-40-90
Красноярск (391)204-63-61
Курск (4712)77-13-04
Липецк (4742)52-20-81
Магнитогорск (3519)55-03-13
Москва (495)268-04-70
Мурманск (8152)59-64-93
Набережные Челны (8552)20-53-41
Нижний Новгород (831)429-08-12
Новокузнецк (3843)20-46-81

Новосибирск (383)227-86-73
Омск (3812)21-46-40
Орел (4862)44-53-42
Оренбург (3532)37-68-04
Пенза (8412)22-31-16
Пермь (342)205-81-47
Ростов-на-Дону (863)308-18-15
Рязань (4912)46-61-64
Самара (846)206-03-16
Санкт-Петербург (812)309-46-40
Саратов (845)249-38-78
Севастополь (8692)22-31-93
Симферополь (3652)67-13-56
Смоленск (4812)29-41-54



Сочи (862)225-72-31
Ставрополь (8652)20-65-13
Сургут (3462)77-98-35
Тверь (4822)63-31-35
Томск (3822)98-41-53
Тула (4872)74-02-29
Тюмень (3452)66-21-18
Ульяновск (8422)24-23-59
Уфа (347)229-48-12
Хабаровск (4212)92-98-04
Челябинск (351)202-03-61
Череповец (8202)49-02-64
Ярославль (4852)69-52-93

Единый адрес для всех регионов: cmn@nt-rt.ru || www.camille-bauer.nt-rt.ru

PROCESS CONTROL ENGINEERING

ANGULAR POSITION ENGINEERING

HEAVY CURRENT ENGINEERING

