

## Программируемый изолирующий усилитель SINEAX TV809

Архангельск (8182)63-90-72  
Астана (7172)727-132  
Астрахань (8512)99-46-04  
Барнаул (3852)73-04-60  
Белгород (4722)40-23-64  
Брянск (4832)59-03-52  
Владивосток (423)249-28-31  
Волгоград (844)278-03-48  
Вологда (8172)26-41-59  
Воронеж (473)204-51-73  
Екатеринбург (343)384-55-89  
Иваново (4932)77-34-06  
Ижевск (3412)26-03-58  
Казань (843)206-01-48

Калининград (4012)72-03-81  
Калуга (4842)92-23-67  
Кемерово (3842)65-04-62  
Киров (8332)68-02-04  
Краснодар (861)203-40-90  
Красноярск (391)204-63-61  
Курск (4712)77-13-04  
Липецк (4742)52-20-81  
Магнитогорск (3519)55-03-13  
Москва (495)268-04-70  
Мурманск (8152)59-64-93  
Набережные Челны (8552)20-53-41  
Нижний Новгород (831)429-08-12  
Новокузнецк (3843)20-46-81

Новосибирск (383)227-86-73  
Омск (3812)21-46-40  
Орел (4862)44-53-42  
Оренбург (3532)37-68-04  
Пенза (8412)22-31-16  
Пермь (342)205-81-47  
Ростов-на-Дону (863)308-18-15  
Рязань (4912)46-61-64  
Самара (846)206-03-16  
Санкт-Петербург (812)309-46-40  
Саратов (845)249-38-78  
Севастополь (8692)22-31-93  
Симферополь (3652)67-13-56  
Смоленск (4812)29-41-54

Сочи (862)225-72-31  
Ставрополь (8652)20-65-13  
Сургут (3462)77-98-35  
Тверь (4822)63-31-35  
Томск (3822)98-41-53  
Тула (4872)74-02-29  
Тюмень (3452)66-21-18  
Ульяновск (8422)24-23-59  
Уфа (347)229-48-12  
Хабаровск (4212)92-98-04  
Челябинск (351)202-03-61  
Череповец (8202)49-02-64  
Ярославль (4852)69-52-93

Единый адрес для всех регионов: [cmn@nt-rt.ru](mailto:cmn@nt-rt.ru) || [www.camille-bauer.nt-rt.ru](http://www.camille-bauer.nt-rt.ru)

использовано с разрешения официального  
дистрибьютора АО «ЮЕ-Интернейшнл»

# SINEAX TV809, 1 channel Programmable Isolating Amplifier

**For electrically insulating, amplifying and converting DC signals**

CE 0102  II (1) Ga  
II (1) Da

## Application

The purpose of the isolating amplifier **SINEAX TV809** (Fig. 1) is to electrically insulate input and output signals, respectively to amplify and/or change the signal level or type (current or voltage) of the input signals.

Measured variables and measuring ranges are programmed with the aid of a PC, a programming cable and the programming software. Specific measured variable data such as analog output signal, transmission characteristics and various functions in combination with the alarm function can also be programmed.

The isolating amplifier fulfils all the important requirements and regulations concerning electromagnetic compatibility **EMV** and **Safety** (EN 61010-1). It was developed and is manufactured and tested in strict accordance with the **quality assurance standard ISO 9001/EN 29001**.

An explosion-proof "Intrinsically safe" [Ex ia Ga] IIC and [Ex ia Da] IIIC version rounds off this series of SINEAX TV809.

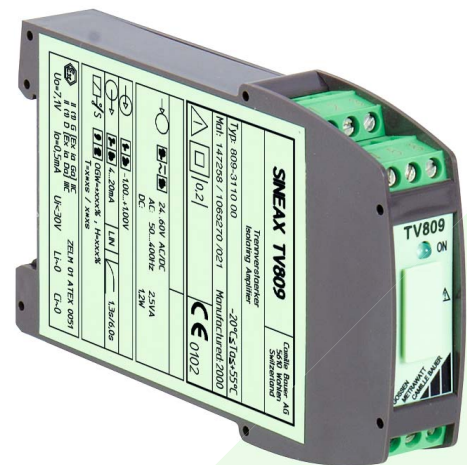

Fig. 1. Isolating amplifier SINEAX TV809 in housing P12/17, terminals not pluggable.

## Features / Benefits

- **Measuring input** (current, voltage, measuring range), **measuring output** (current, voltage, output range) and **relay functions programmed using PC / Simplifies project planning and engineering, short delivery times, low stocking levels**
- **Input voltage up to 1000 V**
- **Short setting time**
- **Programmable input filter**
- **Any conversion factor, also with signal inversion**

- **Possibility to linearize the input signal**
- **Online measurement interrogation and control of the outputs via PC**
- **Built-in alarm relay (optionally)**
- **Wide DC, AC power pack tolerance / Universal**
- **Available in type of protection "Intrinsic safety" [Ex ia Ga] IIC and [Ex ia Da] IIIC**  
(see Table 6: "Data on explosion protection")

## Standard versions

The following versions are available as standard versions already programmed for the **basic** configuration. It is only necessary to quote the **Order No.:**

Table 1: Instruments in standard or Ex version (without alarm relay)

Version	Measuring input*	Measuring output*	Power supply	Screw terminals	Order No.
Standard	programmable within ± 1000 V (Ex max. 30 V) resp. ± 100 mA	programmable within ± 20 mA resp. ± 10 V	24 ... 60 V DC, AC	not pluggable	147 258
			85 ... 230 V DC, AC		147 266
	Basic configuration <b>4 ... 20 mA</b>	Basic configuration <b>4 ... 20 mA</b>	85 ... 230 V DC, AC	pluggable	147 282

\* The type of output variable (current or voltage) is configurable with software.

Please complete the Order Code 809-.... .. according to "Table 7: Ordering information" for versions with user-specific input and/or output ranges.

# SINEAX TV809, 1 channel Programmable Isolating Amplifier

## Programming

A PC, the programming cable PRKAB 600 (for Ex versions) resp. PRKAB 560 (for non-Ex versions) plus ancillary cable and the configuration software TV 800 *plus* are required to program the isolating amplifier.

The connection between "PC ↔ PRKAB 600 resp. 560 ↔ SINEAX TV809" can be seen from Fig. 2. The power supply must be connected in order to configure the SINEAX TV809.

The software TV 800 *plus* is supplied on a CD and runs under Windows 95 or higher.

The programming cable PRKAB 600 resp. PRKAB 560 adapts the signal level and provides galvanic isolation between the PC and the SINEAX TV809 isolating amplifier.

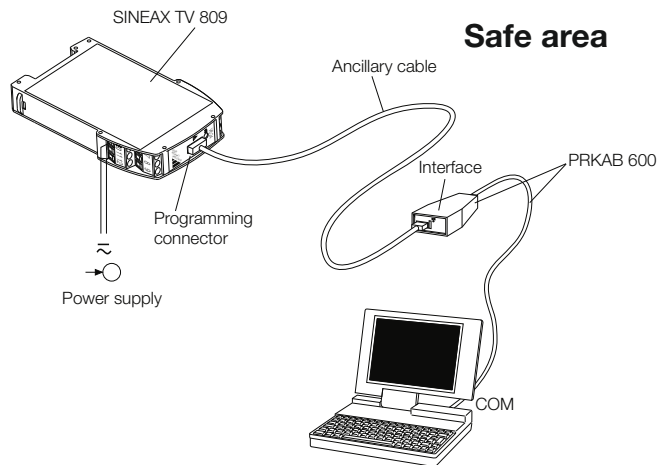

Fig. 2. Programming a SINEAX TV809 in Ex-version.

## Technical data

### Measuring input

DC current:	Type 809 – xx1 Start value/final value between – 100 and 100 mA, $R_i = 15.4 \Omega$ any point may be zero Type 809 – xx2 Start value/final value between – 1.5 and 1.5 mA, $R_i = 1 \text{ k}\Omega$ any point may be zero
DC voltage:	<b>Ex version max. 30 V</b> $\leq \pm 1.7 \text{ V}$ , $R_i = 1 \text{ M}\Omega$ $\pm 1.7 \text{ to } \leq \pm 100 \text{ V}$ , $R_i = 540 \text{ k}\Omega$ $\pm 100 \text{ to } \pm 1000 \text{ V}$ , $R_i = 5.5 \text{ M}\Omega$ Reduced safety see Table 5
Restriction:	Min. span $\geq 0.1 \cdot$ Highest input value quantity Example: Start value = – 5 V Final value = + 3 V Highest input value quantity = 5 V

### Measuring output

DC current, DC voltage and range programmable

<b>DC current:</b>	Reference range – 20 ... 20 mA Start and final values anywhere within the reference range, also with reversed direction, e.g. 20 ... 4 mA; For reduced start or final value, additional error (lower resolution)
Burden voltage:	12 V
Current limit under overload:	Approx. $\pm 22 \text{ mA}$
Open-circuit voltage:	< 16 V
External resistance:	$R_{\text{ext max.}} [\text{k}\Omega] = \frac{12 \text{ V}}{I_{\text{AN}} [\text{mA}]}$ $I_{\text{AN}}$ = Output voltage end value
Residual ripple:	< 0.5% p.p.
<b>DC voltage:</b>	Reference range – 10 ... 10 V Start and final values anywhere within the reference range, also with reversed direction, e.g. + 10 ... – 5 V; For reduced start or final value, additional error (lower resolution)
Voltage limit under overload:	Approx. $\pm 11 \text{ V}$
Short-circuit current:	$\leq 60 \text{ mA}$
External resistance:	$R_{\text{ext min.}} [\text{k}\Omega] \geq \frac{U_{\text{AN}} [\text{V}]}{10 \text{ mA}}$ $U_{\text{AN}}$ = Output voltage end value
Residual ripple:	< 0.5% p.p.

Table 2: Rise time / Setting time

Rise time (63%) [s]		Setting time (99%) [s]	
50 Hz	60 Hz	50 Hz	60 Hz
0.04	0.03	0.08	0.07
0.06	0.05	0.17	0.14
0.10	0.08	0.36	0.30
0.18	0.15	0.72	0.60
0.34	0.28	1.5	1.2
0.66	0.55	3.0	2.5
1.3	1.1	6.0	5.0
2.6	2.2	12	10
5.1	4.3	24	20
10.3	8.6	48	40
20.5	17	94	80
41	34	190	160
82	68	380	315
160	140	750	630
330	270	1500	1260

# SINEAX TV809, 1 channel Programmable Isolating Amplifier

## Programming connector

Interface: Serial interface

## Accuracy data (acc. to EN/IEC 60770-1)

The reference value is the output reference range. For a reduced output range, the relative error increases in proportion to the reduction.

Basic conditions: Error limits  $\leq \pm 0.2\%$   
incl. linearity and reproducibility errors

## Reference conditions

Ambient temperature: 23 °C,  $\pm 2$  K  
Power supply: 24 V DC  $\pm 10\%$  and 230 V AC  $\pm 10\%$   
Output burden: Current: 300  $\Omega$   
Voltage: 2 k $\Omega$

## Influencing factors

Temperature:  $\pm 0.1\%$  per 10 K  
Burden influence:  $\pm 0.1\%$   
Longtime drift:  $\pm 0.3\%$  / 12 months  
Switch-on drift:  $\pm 0.2\%$   
Common and transverse mode influence:  $\pm 0.1\%$   
For voltage input, the transversal error voltage corresponds to the final value selected  
Output + or – connected to ground:  $\pm 0.1\%$

## Power supply

DC, AC power pack (DC or 50...400 Hz)

**Table 3: Nominal voltages and tolerances**

Nominal voltage $U_N$	Tolerance	Instrument versions
24 ... 60 V DC, AC	DC – 15 ... + 33% AC $\pm 15\%$	Standard (Non-Ex)
85 ... 230 V DC, AC		
24 ... 60 V DC, AC	$\pm 10\%$	Type of protection "Intrinsic safety" [Ex ia Ga] IIC [Ex ia Da] IIIC
85 ... 230 V AC		
85 ... 110 V DC		

Power input: 1.2 W resp. 2.5 VA

## Supervising a limit GW ( )

This section is only valid for isolating amplifiers that are ordered and fitted with a relay for limit value indication.

Output contact K: Relay  
1 galvanically isolated switching contact

Trip point type: Programmable

- Inactive
- Low trip point of measured variable (see Fig. 3, left)
- High trip point of measured variable (see Fig. 3, right)

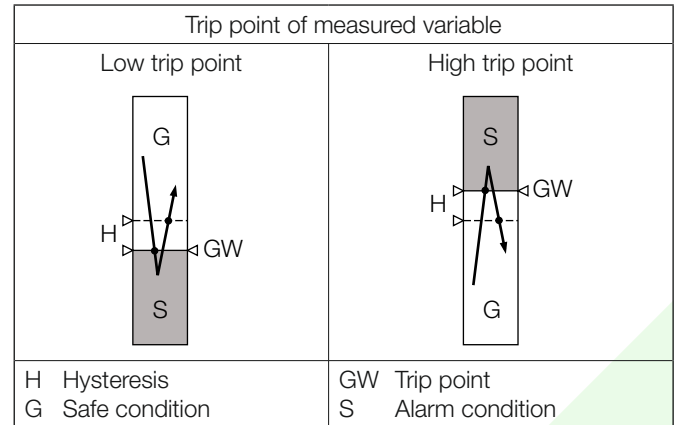

Fig. 3. Switching function, according to trip point type.

Trip point adjustment with PC for trip point:

Programmable  
– between –10 and 110%<sup>1</sup>

Hysteresis:

Programmable  
– between > 0 and 100%<sup>1</sup>

Energizing and de-energizing delays:

Programmable  
– between 0 to 1080 s

Rely contact position:

Programmable  
– see Table 7  
Feature 14

Frontplate signals:

The green LED "ON" flashes when the limit value is exceeded

**Table 4: Contact arrangement and data**

Symbol	Material	Contact rating
	Gold flashed silver alloy	AC: 2 A / 250 V (500 VA) DC: 2 A / 125 V (60 W)

Relay approved by UL, CSA, SEV

## Installation data

Housing: Housing **P12/17** and **P12/17 St**  
Refer to Section "Dimensional drawings" for dimensions

Material of housing: Lexan 940 (polycarbonate)  
Flammability Class V-0 acc. to UL94, self-extinguishing, non-dripping, free of halogen

Mounting: For snapping onto top-hat rail (35x15 mm or 35x7.5 mm) acc. to EN 50022

Position of use: Any

<sup>1</sup> In relation to the analog input value range.

# SINEAX TV809, 1 channel

## Programmable Isolating Amplifier

Electrical terminals: PHOENIX screw terminals with wire guards, for 0.14 mm<sup>2</sup> to 2.5 mm<sup>2</sup>

Weight: Approx. 0.1 kg

**Electrical insulation:** All circuits (measuring input/measuring output/power supply) are electrically insulated

### Regulations

Electromagnetic compatibility: Acc. to EN 61000-6-4 and EN 61000-6-2

Intrinsically safe: Acc. to EN 60079-11, EN 60079-26

Protection (acc. to IEC 529 resp. EN 60529):

Housing IP 40  
Terminals IP 20

Electrical standards: Acc. to IEC 1010-1 resp. EN 61010-1

### Permissible operating voltage acc. to EN 61010-1, 1st edition

(R.M.S. value, increased isolation, contamination level 2, overvoltage category II, up to 2000 m)

Table 5:

	Input	Output	Relay
Power supply	600 V (1000 V)*	600 V	300 V
Input		600 V (1000 V)*	600 V (1000 V)*
Output			300 V

\* Values in brackets are valid for the overvoltage category I

### Test voltage AC / 50 Hz

	Input	Output	Relay
Power supply	3700 V	3700 V	2300 V
Input		3700 V	3700 V
Output			2300 V

### Ambient tests

EN 60068-2-6: Vibration  
Acceleration: ± 2 g  
Frequency range: 10 ... 150 ... 10 Hz, rate of frequency sweep: 1 octave/minute  
Number of cycles: 10, in each of the three axes  
EN 60068-2-27: Shock  
Acceleration: 3 x 50 g  
3 shocks each in 6 directions  
EN 60068-2-1/-2/-3: Cold, dry heat, damp heat

### Environmental conditions

Commissioning temperature: -10 to +55 °C  
Operating temperature: -20 to +55 °C  
Storage temperature: -40 to +70 °C  
Relative humidity: ≤ 75%, without condensation

Table 6: Data on explosion protection  II (1) Ga and  II (1) Da

Order Code	Type of protection "Intrinsic safety" Marking		Type Examination Certificate	Mounting location of the instrument
	Instrument	Measuring input		
809-33/34/93/94	[Ex ia Ga] IIC [Ex ia Da] IIIC	[Ex ia Ga] IIC [Ex ia Da] IIIC	Type Examination Certificate ZELM 01 ATEX 0051	Outside the hazardous area

Table 7: Ordering information (see also Table 1: Standard version)

Description	*Blocking code	No-go with locking code	Article No./ Feature
<b>SINEAX TV809</b> <b>Order Code 809 - xxxx xxxx xxxx xx</b>			809 -
<b>Features, Selection</b>			
<b>1. Mechanical design</b>			
Housing P12/17 for rail mounting, connecting screw terminals not pluggable			3
Housing P12/17 St for rail mounting, connecting screw terminals pluggable			9

# SINEAX TV809, 1 channel Programmable Isolating Amplifier

Description	*Blocking code	No-go with locking code	Article No./ Feature
<b>SINEAX TV809</b> <span style="float: right;"><b>Order Code 809 - xxxx xxxx xxxx xx</b></span>			809 –
<b>Features, Selection</b>			
<b>2. Version / Power supply H</b>			
Standard / 24 ... 60 V DC/AC			1
Standard / 85 ... 230 V DC/AC			2
[Ex ia Ga] IIC and [Ex ia Da] IIIC / 24...60 V DC/AC, input intrinsically safe			3
[Ex ia Ga] IIC and [Ex ia Da] IIIC / 85...110 V DC, 230 V AC, input intrinsically safe			4
<b>3. Current input rating</b>			
Input current, max. final value 100 mA (standard version)	D		1
Input current, max. final value 1.5 mA	E		2
For hardware layout of current input. Must be specified, even if used (programmed) for voltage input only!			
<b>4. Alarm function</b>			
Without alarm function	F		0
With built-in alarm relay			1
<b>5. Test records</b>			
Without test records			0
Test records in German			D
Test records in English			E
<b>6. Configuration</b>			
Basic configuration programmed Specification complete! Basic configuration corresponds with input current max. final value 100 mA, Line 0 in feature 7 to 11 as well as line 0 in feature 12 to 14, without alarm function or line 1 in feature 12 to 14, with alarm function. With input current max. final value 1.5 mA, line 1 in feature 7 corresponds with the basic configuration.	G		0
Programmed to order The following features 7 to 11 resp. 7 to 14 (with alarm contact) must be fully specified.			1
<b>7. Input signal</b>			
Input 4 ... 20 mA		E	0
Input 0 ... 1 mA		D	1
Input <span style="float: right;">[V] <input type="text"/></span>		G	9
Input [V] initial/final value between – 1000 and 1000 at standard version, Ex version max. 30 V! Zero position anywhere, minimal span 0.05 V*			
Input <span style="float: right;">[mA] <input type="text"/></span>		G	Z
Input [mA] at nominal value 100 mA (line 1 in feature 3) initial/final value between – 100 and 100, zero position anywhere, minimal span 3 mA*			
Input [mA] at nominal value 1.5 mA (line 2 in feature 3) initial/final value between – 1.5 and 1.5, zero position anywhere, minimal span 0.09 mA*			
* Minimal span $\geq 0.1 \times$ highest input value quantity			

# SINEAX TV809, 1 channel

## Programmable Isolating Amplifier

Description	*Blocking code	No-go with locking code	Article No./ Feature
<b>SINEAX TV809</b> <span style="float: right;"><b>Order Code 809 - xxxx xxxx xxxx xx</b></span>			809 -
<b>Features, Selection</b>			
<b>8. Output signal</b>			
Output 4 ... 20 mA			0
Output (reference range – 10 ... 10 V) [V]		G	9
Output (reference range – 20 ... 20 mA) [mA]		G	Z
Lines 9 and Z: Any initial and final value within reference range, also with inversed characteristic, e.g. 20 ... 4 mA, + 10 ... – 5 V. <b>Attention!</b> Additional error (lower resolution) for reduced start or final value!			
<b>9. Output characteristic</b>			
Linear			0
Special characteristic (for individual characteristic, on inquiry)		G	9
<b>10. Output time response</b>			
Setting time standard, approx. 80 ms			0
Setting time [s]		G	9
Values from 0.14 to 1500 s in 14 steps, depending on the selected frequency in feature 11; values for 50 and 60 Hz			
<b>11. Mains ripple suppression</b>			
For frequency 50 Hz			0
For frequency 60 Hz		G	1
<b>12. Alarm, type and values</b>			
Alarm function inactive	H		0
High alarm 90%; hysteresis 1% (standard values)	K	F	1
High alarm, hysteresis [%; %]	K	FG	2
Low alarm, hysteresis [%;%]	K	FG	3
Lines 2 and 3: Specify values in % of the input span, Setpoint: Any value between – 10% and 110%, with initial value of measuring range always corresponding to 0%; hysteresis > 0 to 100%. Examples for setpoint (extreme values): Input range:            Input at – 10%:            Input at 110%: 4 ... 20 mA            2.4 mA                            21.6 mA – 10 ... 10 mA        – 12 mA                            12 mA – 5 ... 10 V            – 6.5 V                            11.5 V			
<b>13. Alarm, switching delay</b>			
Alarm function inactive		K	0
Delay energizing/deenergizing 0.2 s (standard)		H	1
Delay energizing/deenergizing [s; s] Energizing and deenergizing delay [s] 0 to 1080		GH	2

# SINEAX TV809, 1 channel Programmable Isolating Amplifier

Description	*Blocking code	No-go with locking code	Article No./ Feature
<b>SINEAX TV809</b> <span style="float: right;"><b>Order Code 809 - xxxx xxxx xxxx xx</b></span>			809 -
<b>Features, Selection</b>			
<b>14. Alarm, mode of action</b>			
Alarm function inactive		K	0
Contact closed in alarm condition and at power loss		H	1
Contact open in alarm condition and at power loss		GH	2
Contact closed in alarm condition, open at power loss		GH	3
Contact open in alarm condition, closed at power loss		GH	4

\* Lines with letter(s) under "no-go" cannot be combined with preceding lines having the same letter under "Blocking Code".

## Electrical connections

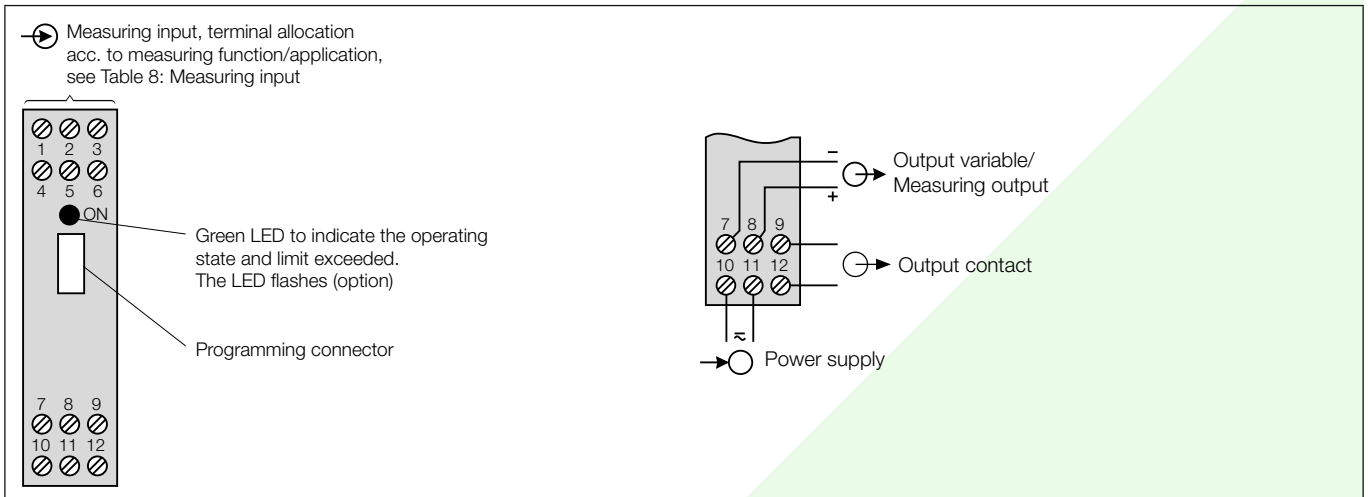

**Table 8: Measuring input**

Measuring function / Application	Measuring range limits	Terminal allocation
DC voltage	$\leq \pm 1.7 \text{ V}$	
	$> \pm 1.7$ to $\leq \pm 100 \text{ V}$	
	$> \pm 100$ to $\pm 1000 \text{ V}$	
DC current	$\leq \pm 100 \text{ mA}$	
	$\leq \pm 1.5 \text{ mA}$	



# SINEAX TV809, 1 channel Programmable Isolating Amplifier

**Table 9: Accessories and spare parts**

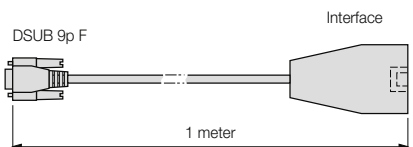
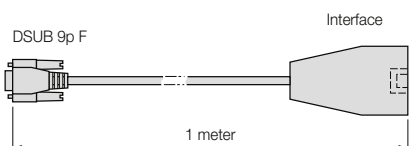
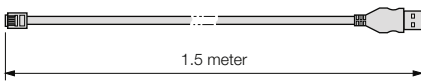
Description	Order No.
Programming cable PRKAB 560 (for programming the SINEAX TV809, nont-Ex) 	147 779
Programming cable PRKAB 600 (for programming the SINEAX TV809 Ex) 	147 787
Ancillary cable for SINEAX Type TV809 	143 587
Configuration software TV 800 <i>plus</i> on CD	146 557
Operating Instructions TV809 Bd in German	147 422
Operating Instructions TV809 Bf in French	147 795
Operating Instructions TV809 Be in English	147 802

**Dimensional drawings**

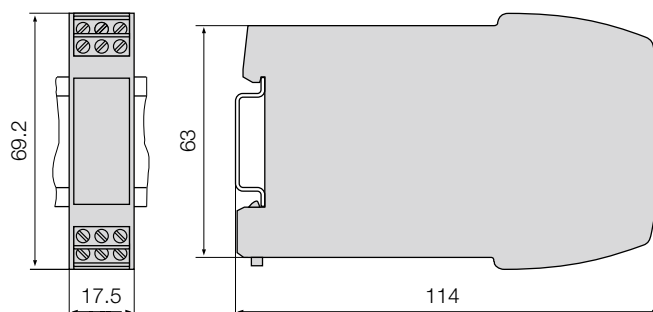

Fig. 4. SINEAX TV809 in housing **P12/17** clipped onto a top-hat rail (35 x 15 mm or 35 x 7.5 mm, acc. to EN 50022), connecting screw terminals not pluggable.

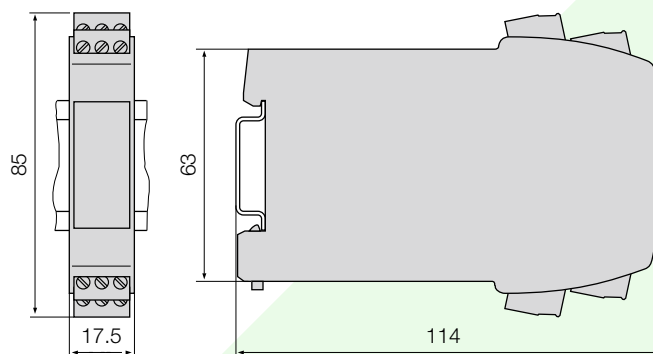

Fig. 5. SINEAX TV809 in housing **P12/17 St** clipped onto a top-hat rail (35 x 15 mm or 35 x 7.5 mm, acc. to EN 50022) connecting screw terminals pluggable.

## Standard accessories

- 1 Operating Instructions in German, French and English
- 1 Type examination certificate (only for "intrinsically safe" explosion-proof devices)

 **CAMILLE BAUER**  
Rely on us.

**По вопросам продажи и поддержки обращайтесь:**

**Архангельск** (8182)63-90-72  
**Астана** (7172)727-132  
**Астрахань** (8512)99-46-04  
**Барнаул** (3852)73-04-60  
**Белгород** (4722)40-23-64  
**Брянск** (4832)59-03-52  
**Владивосток** (423)249-28-31  
**Волгоград** (844)278-03-48  
**Вологда** (8172)26-41-59  
**Воронеж** (473)204-51-73  
**Екатеринбург** (343)384-55-89  
**Иваново** (4932)77-34-06  
**Ижевск** (3412)26-03-58  
**Казань** (843)206-01-48

**Калининград** (4012)72-03-81  
**Калуга** (4842)92-23-67  
**Кемерово** (3842)65-04-62  
**Киров** (8332)68-02-04  
**Краснодар** (861)203-40-90  
**Красноярск** (391)204-63-61  
**Курск** (4712)77-13-04  
**Липецк** (4742)52-20-81  
**Магнитогорск** (3519)55-03-13  
**Москва** (495)268-04-70  
**Мурманск** (8152)59-64-93  
**Набережные Челны** (8552)20-53-41  
**Нижний Новгород** (831)429-08-12  
**Новокузнецк** (3843)20-46-81

**Новосибирск** (383)227-86-73  
**Омск** (3812)21-46-40  
**Орел** (4862)44-53-42  
**Оренбург** (3532)37-68-04  
**Пенза** (8412)22-31-16  
**Пермь** (342)205-81-47  
**Ростов-на-Дону** (863)308-18-15  
**Рязань** (4912)46-61-64  
**Самара** (846)206-03-16  
**Санкт-Петербург** (812)309-46-40  
**Саратов** (845)249-38-78  
**Севастополь** (8692)22-31-93  
**Симферополь** (3652)67-13-56  
**Смоленск** (4812)29-41-54

**Сочи** (862)225-72-31  
**Ставрополь** (8652)20-65-13  
**Сургут** (3462)77-98-35  
**Тверь** (4822)63-31-35  
**Томск** (3822)98-41-53  
**Тула** (4872)74-02-29  
**Тюмень** (3452)66-21-18  
**Ульяновск** (8422)24-23-59  
**Уфа** (347)229-48-12  
**Хабаровск** (4212)92-98-04  
**Челябинск** (351)202-03-61  
**Череповец** (8202)49-02-64  
**Ярославль** (4852)69-52-93

**Единый адрес для всех регионов: [cmn@nt-rt.ru](mailto:cmn@nt-rt.ru) || [www.camille-bauer.nt-rt.ru](http://www.camille-bauer.nt-rt.ru)**

**PROCESS CONTROL ENGINEERING**



**ANGULAR POSITION ENGINEERING**



**HEAVY CURRENT ENGINEERING**

