

SINEAX TV 819, 1 channel Isolating Amplifier unipolar/bipolar

For electrically insulating, amplifying and converting DC signals



Application

The purpose of the active isolating amplifier **SINEAX TV 819** (Fig. 1) is to electrically insulate input and output signals, respectively to amplify and/or change the signal level or type (current or voltage) of the input signals.

The compact SINEAX TV 819 provides a large selection of input and output ranges that can be configured by the user with soldered jumpers and potentiometers.

The amplifier fulfils all the important requirements and regulations concerning electromagnetic compatibility **EMC** and **Safety** (IEC 1010 resp. EN 61 010). It was developed and is manufactured and tested in strict accordance with the **quality assurance standard** ISO 9001.

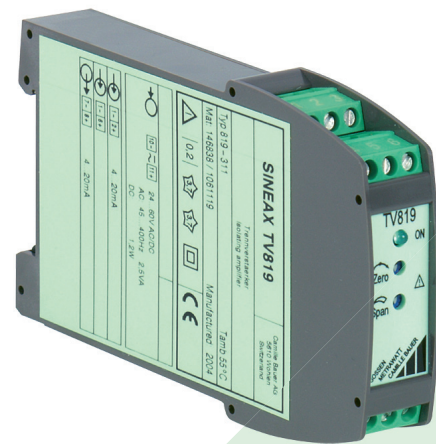

Fig. 1. Isolating amplifier SINEAX TV 819 in housing P12/17 St, terminals not pluggable.

Features / Benefits

- Electric insulation between input, output 3.7 kV and power supply 3.7 kV / Prevents measurement errors due to potential leakage
- Flexibility provided by more than 250 different input and output combinations selected by simply positioning soldered jumpers / Reduced stocking
- Non-standard user-specific ranges available
- Wide DC, AC power pack tolerance / Universal
- Mounting of the isolating amplifier on a top-hat rail
- Housing only 17.5 mm / Low space requirement

Standard versions

Input and output set to 4...20 mA. Any of the standard ranges given in the Section “Technical data, measuring inputs” are simply selected by positioning soldered jumpers. The fine adjustment is accomplished using the potentiometers “Zero” and “Span”. It is only necessary to quote the **Order No.:**

Table 1: Standard versions

Standard range		Power supply	Screw terminals	Order Code	Order No.
Input	Output				
4 ... 20 mA	4 ... 20 mA	24 ... 60 V DC/AC	not pluggable	819 - 311	146 838
		85 ... 230 V DC/AC		819 - 321	146 846
		24 ... 60 V DC/AC	pluggable	819 - 911	146 854
		85 ... 230 V DC/AC		819 - 921	146 862

Please complete the Order Code 819-.... according to “Table 3: Ordering information” for versions with user-specific input and/or output ranges.

SINEAX TV 819, 1 channel

Isolating Amplifier unipolar/bipolar

Technical data

Measuring input $\rightarrow \ominus$

DC current: Limit values
 0...0.1 to 0...40 mA
 also live-zero, start value
 >0 to $\leq 50\%$ final value
 or
 span 0.1 to 40 mA
 between -40 and 40 mA
 (also bipolar asymmetrical)

DC voltage: Limit values
 0...0.06 to 0...1000 V
 also live-zero, start value
 >0 to $\leq 50\%$ final value
 or
 span 0.06 to 1000 V
 between -1000 and 1000 V
 (also bipolar asymmetrical)

Overload capacity: DC current
 continuously 2-fold
 DC voltage
 continuously 2-fold

Measuring output $\ominus \rightarrow$

DC current: Standard ranges
 0...20 mA, 4...20 mA, ± 20 mA
 Limit values
 0...1 to 0...20 mA
 0.2...1 to 4...20 mA
 -1...0...+1 to -20...0...+20 mA

Burden voltage: 12 V

External resistance: $R_{\text{ext max.}} [\text{k}\Omega] = \frac{12 \text{ V}}{I_{\text{AN}} [\text{mA}]}$
 I_{AN} = Output circuit full-scale value

DC voltage: Standard ranges
 0...10 V, 2...10 V, ± 10 V
 Limit values
 0...1 to 0...10 V
 0.2...1 to 2...10 V
 -1...0...+1 to -10...0...+10 V

Burden: $R_{\text{ext min.}} [\text{k}\Omega] \geq \frac{U_{\text{AN}} [\text{V}]}{5 \text{ mA}}$
 U_{AN} = Output circuit full-scale value

Current limiter at $R_{\text{ext max.}}$: Approx. $1.1 \times I_{\text{AN}}$ for current output

Voltage limiter at $R_{\text{ext}} = \infty$: Approx. 13 V

Residual ripple in output current: < 0.5% p.p.

Response time: < 100 ms

Power supply $\rightarrow \bigcirc$

DC, AC power pack (DC or 45...400 Hz)

Table 2: Nominal voltages and tolerances

Nominal voltage U_N	Tolerance
24 ... 60 V DC / AC	DC - 15 ... + 33%
85 ... 230 V DC / AC	AC $\pm 15\%$

Power input: ≤ 1.5 W resp. ≤ 3 VA

Accuracy data (acc. to EN/IEC 60 770-1)

Basic accuracy: Limit error $\leq \pm 0.2\%$
 including linearity and reproducibility errors

Reference conditions:

Ambient temperature: 23 °C, ± 2 K

Power supply: 24 VDC $\pm 10\%$ and 230 VAC $\pm 10\%$

Output burden: Current: $0.5 \cdot R_{\text{ext max.}}$
 Voltage: $2 \cdot R_{\text{ext min.}}$

Influencing factors:

Temperature: $< \pm 0.1\%$ per 10 K

Burden influence: $< \pm 0.1\%$ for current output
 $< \pm 0.2\%$ for voltage output
 if $R_{\text{ext}} < 2 \cdot R_{\text{ext min.}}$

Longtime drift: $< \pm 0.3\%$ / 12 months

Switch-on drift: $< \pm 0.2\%$

Common and transverse mode influence: $< \pm 0.2\%$

Output + or - connected to ground: $< \pm 0.2\%$

Installation data

Mechanical design: Housing **P12/17** and **P12/17 St**
 See section "Dimensional drawings" for dimensions

Material of housing: Lexan 940 (polycarbonate)
 flammability class V-0 acc. to UL 94, self-extinguishing, non-dripping, free of halogen

Mounting: For snapping onto top-hat rail
 (35 x 15 mm or 35 x 7.5 mm) acc. to EN 50 022

Position of use: Any

Electrical terminals (fixed or pluggable): PHOENIX screw terminals with wire guards, for 0.14 mm² to 2.5 mm²

Weight: Approx. 0.1 kg

SINEAX TV 819, 1 channel Isolating Amplifier unipolar/bipolar

Electrical insulation: All circuits (measuring inputs / measuring outputs / power supply) are electrically insulated

Regulations

Electromagnetic compatibility: The standards EN 50 081-2 and EN 50 082-2 are observed

Protection (acc. to IEC 529 resp. EN 60 529): Housing IP 40
Terminals IP 20

Electrical standards: Acc. to IEC 1010 resp. EN 61 010

Permissible operating voltages acc. to EN 61 010-1

Increased isolation, contamination level 2, overvoltage category II, to 2000 m above sea level

	Input	Output
Power supply	1000 V	300 V
Input		600 V (1000 V)*

* Values in brackets are valid for overvoltage category I

Test voltages AC / 50 Hz / 1 minute

	Input	Output
Power supply	3700 V	3700 V
Input		3700 V

Ambient tests

EN 60 068-2-6: Vibration
Acceleration: ± 2 g
Frequency range: 10 ... 150 ... 10 Hz, rate of frequency sweep: 1 octave/minute

Number of cycles: 10, in each of the three axes

EN 60 068-2-27: Shock
Acceleration: 3×50 g
3 shocks each in 6 directions

EN 60 068-2-1/-2/-3: Cold, dry heat, damp heat

Environmental conditions

Commissioning temperature: -10 to $+55$ °C

Operating temperature: -25 to $+55$ °C

Storage temperature: -40 to $+70$ °C

Annual mean relative humidity: $\leq 75\%$

Altitude: 2000 m max.

Indoor use statement!

Table 3: Ordering information

(see also Table 1: "Standard versions")

Description	Marking
Order Code	819 -
1. Mechanical design	
Housing P12/17 for rail mounting, screw terminals not pluggable	3
Housing P12/17 St for rail mounting, screw terminals pluggable	9
2. Version / Power supply	
Standard, 24 ... 60 V DC/AC	1
Standard, 85 ... 230 V DC/AC	2
3. Function	
1 input max. 1000 V, 1 electrically insulated output	1
4. Input signal	
Input [V] []	9
[V] 0 ... 0.06 to 0 ... 1000, also live-zero, start value > 0 to 50% final value or span 0.06 to 1000 V between -1000 and 1000 , also bipolar asymmetrical	
Input [mA] []	Z
[mA] 0 ... 0.1 to 0 ... 40, also live-zero, start value > 0 to 50% final value or span 0.1 to 40 mA between -40 and 40 mA, also bipolar asymmetrical	
5. Output signal	
Output [V] []	9
[V] 0 ... 1 to 0 ... 10, 0.2 ... 1 to 2 ... 10 -1 ... 0 ... $+1$ to -10 ... 0 ... $+10$	
Output [mA] []	Z
[mA] 0 ... 1 to 0 ... 20, 0.2 ... 1 to 4 ... 20 -1 ... 0 ... $+1$ to -20 ... 0 ... $+20$	
6. Output characteristic	
Standard (directly proportional, $0 \dots Y / 0.2Y \dots Y / -Y \dots 0 \dots +Y$)	0
Inversely proportional, $(Y \dots 0 / Y \dots 0.2Y / +Y \dots 0 \dots -Y)$	1
7. Test certificate	
Without test certificate	0
Test certificate in German	D
Test certificate in English	E

Y = Output circuit full-scale value

SINEAX TV 819, 1 channel

Isolating Amplifier unipolar/bipolar

Dimensional drawings

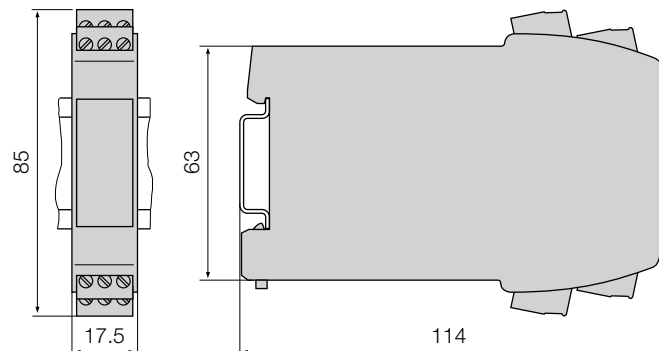
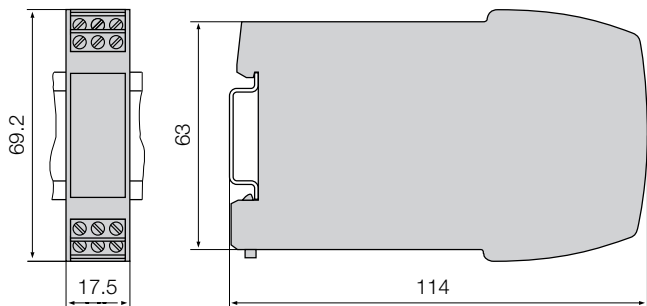

Fig. 2. SINEAX TV 819 in carrying rail housing **P12/17** clipped onto a top-hat rail (35 × 15 mm or 35 × 7.5 mm, acc. to EN 50 022), screw terminals not pluggable.

Fig. 3. SINEAX TV 819 in carrying rail housing **P12/17 St** clipped onto a top-hat rail (35 × 15 mm or 35 × 7.5 mm, acc. to EN 50 022), screw terminals pluggable.

Electrical connections

Measuring function / Application	DC voltage (direct input)	DC current	DC voltage (input via potential divider)
Measuring span	0.06 ... 40 V	0.1 ... 40 mA	> 40 ... 1000 V
Measuring range limits taking account of the max. measuring span	- 40 ... 0 ... 40 V	- 40 ... 0 ... 40 mA	- 1000 ... 0 ... 1000 V
Electrical connections			

Standard accessories

1 Operating Instructions in German, French and English

 **CAMILLE BAUER**
Rely on us.

По вопросам продажи и поддержки обращайтесь:

Архангельск (8182)63-90-72
Астана (7172)727-132
Астрахань (8512)99-46-04
Барнаул (3852)73-04-60
Белгород (4722)40-23-64
Брянск (4832)59-03-52
Владивосток (423)249-28-31
Волгоград (844)278-03-48
Вологда (8172)26-41-59
Воронеж (473)204-51-73
Екатеринбург (343)384-55-89
Иваново (4932)77-34-06
Ижевск (3412)26-03-58
Казань (843)206-01-48

Калининград (4012)72-03-81
Калуга (4842)92-23-67
Кемерово (3842)65-04-62
Киров (8332)68-02-04
Краснодар (861)203-40-90
Красноярск (391)204-63-61
Курск (4712)77-13-04
Липецк (4742)52-20-81
Магнитогорск (3519)55-03-13
Москва (495)268-04-70
Мурманск (8152)59-64-93
Набережные Челны (8552)20-53-41
Нижний Новгород (831)429-08-12
Новокузнецк (3843)20-46-81

Новосибирск (383)227-86-73
Омск (3812)21-46-40
Орел (4862)44-53-42
Оренбург (3532)37-68-04
Пенза (8412)22-31-16
Пермь (342)205-81-47
Ростов-на-Дону (863)308-18-15
Рязань (4912)46-61-64
Самара (846)206-03-16
Санкт-Петербург (812)309-46-40
Саратов (845)249-38-78
Севастополь (8692)22-31-93
Симферополь (3652)67-13-56
Смоленск (4812)29-41-54

Сочи (862)225-72-31
Ставрополь (8652)20-65-13
Сургут (3462)77-98-35
Тверь (4822)63-31-35
Томск (3822)98-41-53
Тула (4872)74-02-29
Тюмень (3452)66-21-18
Ульяновск (8422)24-23-59
Уфа (347)229-48-12
Хабаровск (4212)92-98-04
Челябинск (351)202-03-61
Череповец (8202)49-02-64
Ярославль (4852)69-52-93

Единый адрес для всех регионов: cmn@nt-rt.ru || www.camille-bauer.nt-rt.ru

PROCESS CONTROL ENGINEERING



ANGULAR POSITION ENGINEERING



HEAVY CURRENT ENGINEERING

