



Изолирующий усилитель SINEAX TV808-11, TV808-118, TV808-12

Архангельск (8182)63-90-72
Астана (7172)727-132
Астрахань (8512)99-46-04
Барнаул (3852)73-04-60
Белгород (4722)40-23-64
Брянск (4832)59-03-52
Владивосток (423)249-28-31
Волгоград (844)278-03-48
Вологда (8172)26-41-59
Воронеж (473)204-51-73
Екатеринбург (343)384-55-89
Иваново (4932)77-34-06
Ижевск (3412)26-03-58
Казань (843)206-01-48

Калининград (4012)72-03-81
Калуга (4842)92-23-67
Кемерово (3842)65-04-62
Киров (8332)68-02-04
Краснодар (861)203-40-90
Красноярск (391)204-63-61
Курск (4712)77-13-04
Липецк (4742)52-20-81
Магнитогорск (3519)55-03-13
Москва (495)268-04-70
Мурманск (8152)59-64-93
Набережные Челны (8552)20-53-41
Нижний Новгород (831)429-08-12
Новокузнецк (3843)20-46-81

Новосибирск (383)227-86-73
Омск (3812)21-46-40
Орел (4862)44-53-42
Оренбург (3532)37-68-04
Пенза (8412)22-31-16
Пермь (342)205-81-47
Ростов-на-Дону (863)308-18-15
Рязань (4912)46-61-64
Самара (846)206-03-16
Санкт-Петербург (812)309-46-40
Саратов (845)249-38-78
Севастополь (8692)22-31-93
Симферополь (3652)67-13-56
Смоленск (4812)29-41-54

Сочи (862)225-72-31
Ставрополь (8652)20-65-13
Сургут (3462)77-98-35
Тверь (4822)63-31-35
Томск (3822)98-41-53
Тула (4872)74-02-29
Тюмень (3452)66-21-18
Ульяновск (8422)24-23-59
Уфа (347)229-48-12
Хабаровск (4212)92-98-04
Челябинск (351)202-03-61
Череповец (8202)49-02-64
Ярославль (4852)69-52-93

Единый адрес для всех регионов: cmn@nt-rt.ru || www.camille-bauer.nt-rt.ru

использовано с разрешения официального
дистрибьютора АО «ЮЕ-Интернейшнл»

SINEAX TV 808, 1 channel Isolating Amplifier unipolar/bipolar

For electrically insulating, amplifying and converting DC signals

CE 0102  II (1) G

Application

The purpose of the isolating amplifier **SINEAX TV 808** (Fig. 1 and 2) is to electrically insulate input and output signals, respectively to amplify and/or change the signal level or type (current or voltage) of the input signals.

Variants

-  and non-Ex isolating amplifiers
- 36 standard input and output combinations selected by plug-in jumpers
- User-specific input and/or output ranges
- Power supply 24...60 V DC/AC or 85...230 V DC/AC

Please request our data sheet TV 808-12 Le for two-channel versions.

Features / Benefits

- Electric insulation between input, output (2.3 kV) and power supply (3.7 kV) / Prevents measurement errors due to potential leakage
- Flexibility provided by 36 different input and output combinations selected by simply positioning plug-in jumpers / No influence on accuracy / Reduced stocking
- Non-standard user-specific ranges available
- AC/DC power supply / Universal
- Available in type of protection "Intrinsic safety" [EEx ia] IIC (see "Table 4: Data on explosion protection")
- Provision for either snapping the isolating amplifier onto top-hat rails or securing it with screws to a wall or panel
- Housing only 17.5 mm (size S17 housing) / Low space requirement

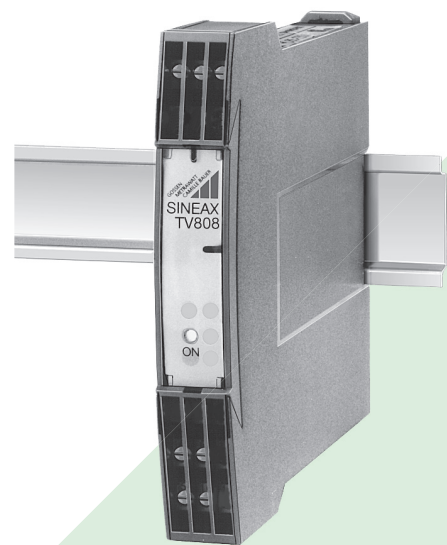

Fig. 1. Isolating amplifier SINEAX TV 808 in housing S17 clipped onto a top-hat rail.



Fig. 2. Isolating amplifier SINEAX TV 808 in housing S17 screw hole mounting brackets pulled out.

SINEAX TV 808, 1 channel

Isolating Amplifier unipolar/bipolar

Standard versions

Input and output set to 0...20 mA. Any of the standard ranges simply selected by positioning plug-in jumpers without influencing measurement accuracy.

Table 1: Standard (non-Ex) version

Standard ranges		Power supply	Order Code	Article Number
Input	Output			
0 ... 20 mA 4 ... 20 mA, ± 20 mA 2 ... 10 V, ± 10 V 0 ... 10 V	0 ... 20 mA 4 ... 20 mA, ± 20 mA 2 ... 10 V, ± 10 V 0 ... 10 V	24 ... 60 V DC/AC	808 – 1111	124 404
		85 ... 230 V DC/AC	808 – 1121	124 412

Please complete the Order Code 808 - 11.1 .. according to Table 3 "Ordering informations" for versions with user-specific input and/or output ranges.

Technical data

Measuring input \rightarrow

DC current: Standard ranges
0...20 mA, 4...20 mA, ± 20 mA
Limit values 0...0.1 to 0...50 mA
also live-zero,
start value > 0 to ≤ 50% final value
-0.1...0...+ 0.1 to
-50...0...+ 50 mA
also bipolar asymmetrical
 $R_i = 15 \Omega$

DC voltage: Standard ranges
0...10 V, 2...10 V, ± 10 V
Limit values
0...0.06 to 0...40, **Ex max. 30 V**
also live-zero,
start value > 0 to ≤ 50% final value
-0.06...0...+ 0.06 to
-40...0...+ 40 V,
Ex max. -30...0...+ 30 V
 $R_i = 100 \text{ k}\Omega$

Overload: DC current continuously 2 fold
DC voltage continuously 2-fold

Measuring output \rightarrow

DC current: Standard ranges
0...20 mA, 4...20 mA, ± 20 mA
limit values
0...1 to 0...20 mA
0.2...1 to 4...20 mA
-1...0...+ 1 to -20...0...+ 20 mA

Burden voltage: 12 V

External resistance: $R_{\text{ext max.}} [\text{k}\Omega] = \frac{12 \text{ V}}{I_{\text{AN}} [\text{mA}]}$
 $I_{\text{AN}} = \text{Output circuit full-scale value}$

DC voltage: Standard ranges
0...10 V, 2...10 V, ± 10 V
Limit values
0...1 to 0...10 V
0.2...1 to 2...10 V
-1...0...+ 1 to -10...0...+ 10 V

Burden: $R_{\text{ext min.}} [\text{k}\Omega] \geq \frac{U_{\text{AN}} [\text{V}]}{5 \text{ mA}}$

Current limiter at $R_{\text{ext max.}}$: Approx. $1.1 \times I_{\text{AN}}$ for current output

Voltage limiter at $R_{\text{ext}} = \infty$: Approx. 13 V

Residual ripple in output current: < 0.5% p.p.

Response time: < 50 ms

Power supply H \rightarrow

AC/DC power pack (DC and 45...400 Hz)

Table 2: Nominal voltages and tolerances

Nominal voltage U_N	Tolerance	Instrument version
24 ... 60 V DC/AC	DC - 15 ... + 33%	Standard (non-Ex)
85 ... 230 V ¹ DC/AC	AC ± 15%	
24 ... 60 V DC/AC	DC - 15 ... + 33%	Type of protection «Intrinsically safe» [Ex ia] IIC
85 ... 230 V AC	± 10%	
85 ... 110 V DC	- 15 ... + 10%	

Power input: ≤ 1.2 W resp. ≤ 3 VA

Accuracy data (acc. to DIN/IEC 770)

Basic accuracy: Limit error ≤ ± 0.2%
Including linearity and reproducibility errors

¹ For power supplies > 125 V, the auxiliary circuit should include an external fuse with a rating ≤ 20 A DC.

SINEAX TV 808, 1 channel Isolating Amplifier unipolar/bipolar

Reference conditions:

Ambient temperature	23 °C, ± 2 K
Power supply	24 V DC ± 10% and 230 V AC ± 10%
Output burden	Current: $0.5 \cdot R_{\text{ext}} \text{ max.}$ Voltage: $2 \cdot R_{\text{ext}} \text{ min.}$

Influencing factors:

Temperature	< ± 0.1% per 10 K
Bürdeeinfluss	< ± 0.1% for current output < ± 0,2% for voltage output if $R_{\text{ext}} < 2 \cdot R_{\text{ext}} \text{ min.}$
Longtime drift	< ± 0.3% / 12 months
Switch-on drift	< ± 0.2%
Common and transverse mode influence	< ± 0.2%
Output + or – connected to ground	< ± 0.2%

Installation data

Housing:	Housing S17 See section «Dimensional drawings»
Material of housing:	Lexan 940 (polycarbonate) flammability class V-0 acc. to UL 94, self-extinguishing, non-dripping, free of halogen
Mounting:	For snapping onto top-hat rail (35 × 15 mm or 35 × 7.5 mm) acc. to EN 50 022 or directly onto a wall or panel using the pull-out screw hole brackets
Position of use:	Any
Terminals:	DIN/VDE 0609 Screw terminals with wire guards, for light PVC wiring and max. 2 × 0.75 mm ² or 1 × 2.5 mm ²
Permissible vibrations:	2 g acc. to EN 60 068-2-6
Shock:	3 × 50 g 3 shocks each in 6 directions acc. to EN 60 068-2-27
Weight:	Approx. 0.18 kg

Electrical insulation:

All circuits (measuring input / measuring output / power supply) are electrically insulated

Regulations

Electromagnetic compatibility:	The standards DIN EN 50 081-2 and DIN EN 50 082-2 are observed
Intrinsically safe:	Acc. to EN 50 020: 1996-04
Protection (acc. to IEC 529 resp. EN 60 529):	Housing IP 40 Terminals IP 20
Electrical standards:	Acc. to IEC 1010 resp. EN 61 010
Operating voltages:	< 300 V between all insulated circuits
Contamination level:	2
Overvoltage category acc. to IEC 664:	III for power supply II for measuring input and measuring output
Double insulation:	Power supply versus all other circuits Measuring input versus measuring output
Test voltage:	Measuring input versus: Measuring output 2,3 kV, 50 Hz, 1 min. Power supply 3,7 kV, 50 Hz, 1 min. Measuring output versus: power supply 3.7 kV, 50 Hz, 1 Min.

Environmental conditions

Climatic rating:	Climate class 3Z acc. to VDI/VDE 3540
Commissioning temperature:	– 10 to + 55 °C
Operating temperature:	– 25 to + 55 °C, Ex – 20 to + 55 °C
Storage temperature:	– 40 to + 70 °C
Annual mean relative humidity:	≤ 75%
Altitude:	2000 m max.
Indoor use only!	

SINEAX TV 808, 1 channel

Isolating Amplifier unipolar/bipolar

Table 3: Ordering informations

(see also Table 1: "Standard versions")

Description	Marking
1. Mechanical design Housing S17 for rail and wall mounting	808 - 1
2. Number of channels 1 channel	1
3. Version / Power supply	
Standard / 24 ... 60 V DC/AC	1
Standard / 85 ... 230 V DC/AC	2
[EEx ia] IIC / 24 ... 60 V DC/AC (Input intrinsically safe)	3
[EEx ia] IIC / 85 ... 110 V DC / 230 V AC (Input intrinsically safe)	4
4. Function 1 input, 1 electrically insulated output	1
5. Input signal	
Input [V] <input type="text"/> [V] 0 ... 0.06 to 0 ... 40, Ex max. 30 also live-zero, start value > 0 to ≤ 50% final value [V] - 0.06 ... 0 ... + 0.06 to - 40 ... 0 ... + 40, Ex max. - 30 ... 0 ... + 30 also bipolar asymmetrical	9
Input [mA] <input type="text"/> [mA] 0 ... 0.1 to 0 ... 50 also live-zero, start value > 0 to ≤ 50% final value [mA] - 0.1 ... 0 ... + 0.1 to - 50 ... 0 ... + 50 also bipolar asymmetrical	Z

Description	Marking
6. Output signal	
Output [V] <input type="text"/> [V] 0 ... 1 to 0 ... 10 0.2 ... 1 to 2 ... 10 - 1 ... 0 ... + 1 to - 10 ... 0 ... + 10	9
Output [mA] <input type="text"/> [mA] 0 ... 1 to 0 ... 20 0.2 ... 1 to 4 ... 20 - 1 ... 0 ... + 1 to - 20 ... 0 ... + 20	Z

Possible special versions, e.g. increased climatic rating on inquiry.

Table 4: Data on explosion protection  **II (1) G**

Order code	Type of protection	Input	Output	Type Examination Certificate	Mounting location
808 - 113. ...	[EEx ia] IIC	$U_o = 6 \text{ V}$ $I_o = 63 \mu\text{A}$ $L_i = 20 \mu\text{H}$ $C_i = 20 \text{ nF}$ only for connection to certified intrinsically safe circuits with following maximum value: $U_o = 30 \text{ V}$	$U_m = 253 \text{ V AC}$ resp. 125 V DC	PTB 97 ATEX 2191	Outside the hazardous area

SINEAX TV 808, 1 channel Isolating Amplifier unipolar/bipolar

Electrical connections

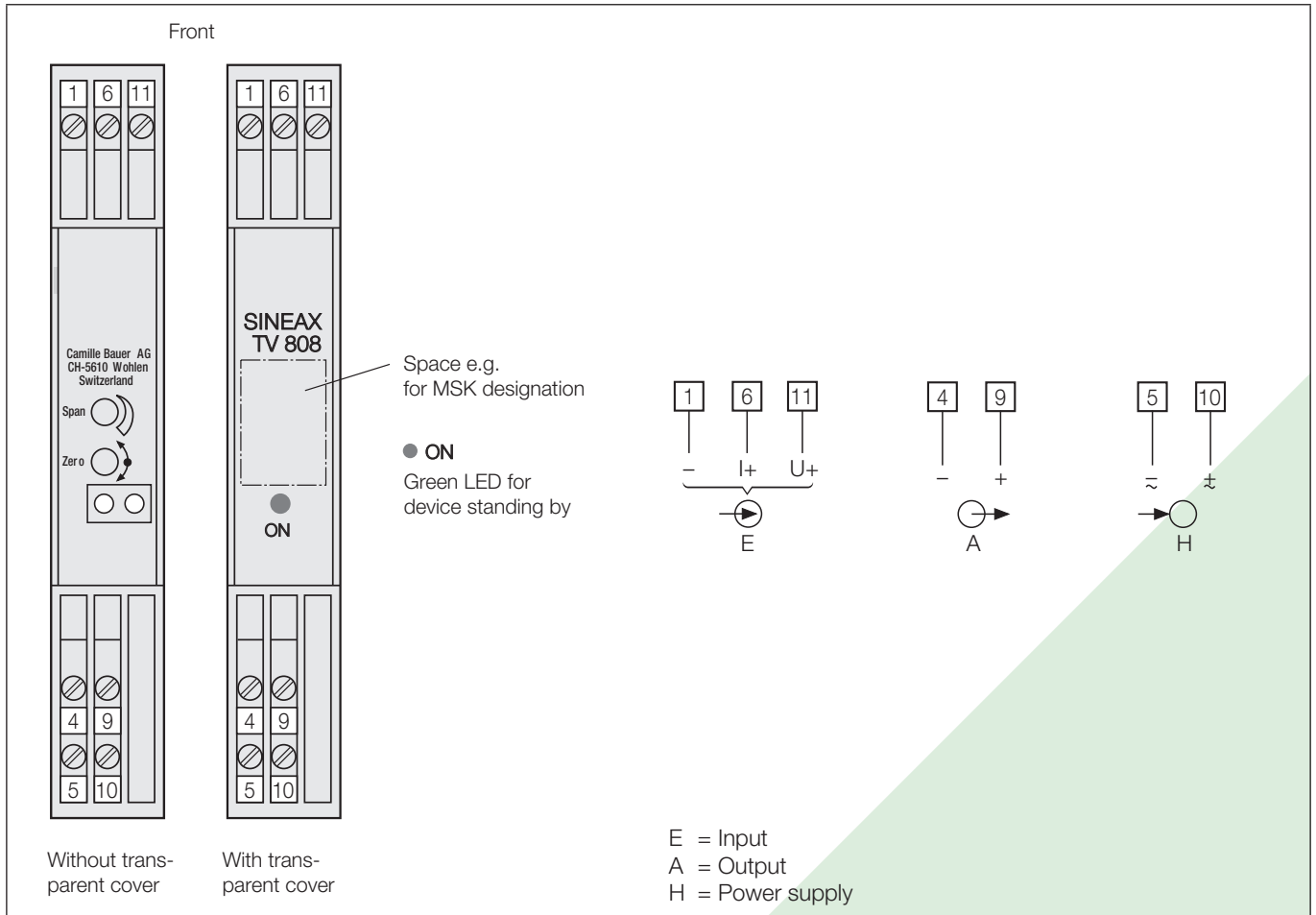

Configuration

The SINEAX TV 808 unit has to be opened before it can be configured.

Type of output signal (voltage or current)

The output can be configured for a voltage or current signal by inserting the plug-in jumpers **ST 4** and **ST 3** in position “U” or “I” (Fig. 3).

Output \rightarrow	Jumpers	
	ST 4	ST 3
Voltage [V]		
Current [mA]		

Standard input and output ranges

Two of the six plug-in jumpers **B1** to **B6** are used for selecting the standard ranges of the isolating amplifiers. Providing the potentiometers “Span” and “Zero” are not moved, changing the range has no influence on amplifier accuracy.

		4...20 mA	0...20 mA	-20...20 mA	2...10 V	0...10 V	-10...10 V
	4 ... 20 mA	B1, B4	B2, B4	B3, B4	B1, B4	B2, B4	B3, B4
	0 ... 20 mA	B1, B5	B2, B5	B3, B5	B1, B5	B2, B5	B3, B5
	-20 ... 20 mA	B1, B6	B2, B6	B3, B6	B1, B6	B2, B6	B3, B6
	2 ... 10 V	B1, B4	B2, B4	B3, B4	B1, B4	B2, B4	B3, B4
	0 ... 10 V	B1, B5	B2, B5	B3, B5	B1, B5	B2, B5	B3, B5
	-10 ... 10 V	B1, B6	B2, B6	B3, B6	B1, B6	B2, B6	B3, B6

SINEAX TV 808, 1 channel

Isolating Amplifier unipolar/bipolar

The default setting of the preferred versions ex stock is 0 ... 20 mA for input and output, i.e. jumpers are inserted in positions B2 and B5 and jumpers ST 4 and ST 3 are in position "I".

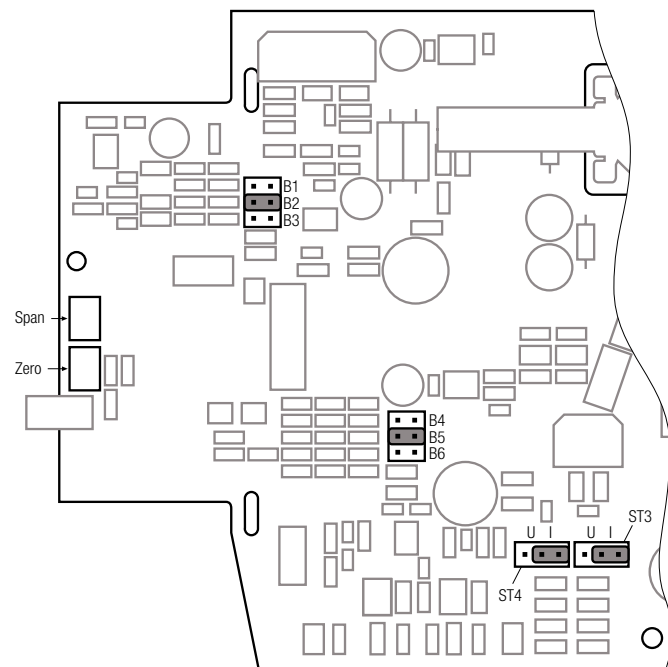

Fig. 3. Position of the jumpers ST 4 and ST 3, B1 to B6 and the potentiometer "Span" and "Zero".

Standard accessories

- 1 Operating Instructions in three languages: German, French, English
- 2 Withdrawing handle (for opening the housing)
- 2 Labels (under transparent cover)
- 1 Type Examination Certificate (for instruments in type of protection "Intrinsically safe" only)

Dimensional drawings

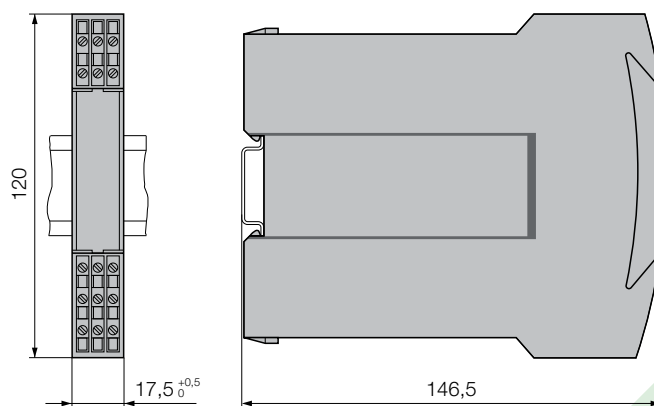

Fig. 4. SINEAX TV 808 in housing S17 clipped onto a top-hat rail (35 x 15 mm or 35 x 7.5 mm, acc. to EN 50 022).

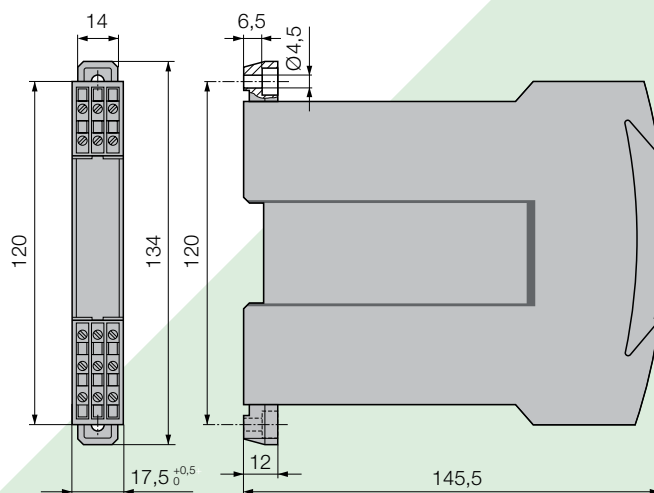

Fig. 5. SINEAX TV 808 in housing S17, screw hole mounting brackets pulled out.

 **CAMILLE BAUER**
Rely on us.

По вопросам продажи и поддержки обращайтесь:

Архангельск (8182)63-90-72
Астана (7172)727-132
Астрахань (8512)99-46-04
Барнаул (3852)73-04-60
Белгород (4722)40-23-64
Брянск (4832)59-03-52
Владивосток (423)249-28-31
Волгоград (844)278-03-48
Вологда (8172)26-41-59
Воронеж (473)204-51-73
Екатеринбург (343)384-55-89
Иваново (4932)77-34-06
Ижевск (3412)26-03-58
Казань (843)206-01-48



Калининград (4012)72-03-81
Калуга (4842)92-23-67
Кемерово (3842)65-04-62
Киров (8332)68-02-04
Краснодар (861)203-40-90
Красноярск (391)204-63-61
Курск (4712)77-13-04
Липецк (4742)52-20-81
Магнитогорск (3519)55-03-13
Москва (495)268-04-70
Мурманск (8152)59-64-93
Набережные Челны (8552)20-53-41
Нижний Новгород (831)429-08-12
Новокузнецк (3843)20-46-81

Новосибирск (383)227-86-73
Омск (3812)21-46-40
Орел (4862)44-53-42
Оренбург (3532)37-68-04
Пенза (8412)22-31-16
Пермь (342)205-81-47
Ростов-на-Дону (863)308-18-15
Рязань (4912)46-61-64
Самара (846)206-03-16
Санкт-Петербург (812)309-46-40
Саратов (845)249-38-78
Севастополь (8692)22-31-93
Симферополь (3652)67-13-56
Смоленск (4812)29-41-54



Сочи (862)225-72-31
Ставрополь (8652)20-65-13
Сургут (3462)77-98-35
Тверь (4822)63-31-35
Томск (3822)98-41-53
Тула (4872)74-02-29
Тюмень (3452)66-21-18
Ульяновск (8422)24-23-59
Уфа (347)229-48-12
Хабаровск (4212)92-98-04
Челябинск (351)202-03-61
Череповец (8202)49-02-64
Ярославль (4852)69-52-93

Единый адрес для всех регионов: cmn@nt-rt.ru || www.camille-bauer.nt-rt.ru

PROCESS CONTROL ENGINEERING

ANGULAR POSITION ENGINEERING

HEAVY CURRENT ENGINEERING

