

## Трансмиттер углового положения KINAX HW730 / HW730-Ex

Архангельск (8182)63-90-72  
Астана (7172)727-132  
Астрахань (8512)99-46-04  
Барнаул (3852)73-04-60  
Белгород (4722)40-23-64  
Брянск (4832)59-03-52  
Владивосток (423)249-28-31  
Волгоград (844)278-03-48  
Вологда (8172)26-41-59  
Воронеж (473)204-51-73  
Екатеринбург (343)384-55-89  
Иваново (4932)77-34-06  
Ижевск (3412)26-03-58  
Казань (843)206-01-48

Калининград (4012)72-03-81  
Калуга (4842)92-23-67  
Кемерово (3842)65-04-62  
Киров (8332)68-02-04  
Краснодар (861)203-40-90  
Красноярск (391)204-63-61  
Курск (4712)77-13-04  
Липецк (4742)52-20-81  
Магнитогорск (3519)55-03-13  
Москва (495)268-04-70  
Мурманск (8152)59-64-93  
Набережные Челны (8552)20-53-41  
Нижний Новгород (831)429-08-12  
Новокузнецк (3843)20-46-81

Новосибирск (383)227-86-73  
Омск (3812)21-46-40  
Орел (4862)44-53-42  
Оренбург (3532)37-68-04  
Пенза (8412)22-31-16  
Пермь (342)205-81-47  
Ростов-на-Дону (863)308-18-15  
Рязань (4912)46-61-64  
Самара (846)206-03-16  
Санкт-Петербург (812)309-46-40  
Саратов (845)249-38-78  
Севастополь (8692)22-31-93  
Симферополь (3652)67-13-56  
Смоленск (4812)29-41-54

Сочи (862)225-72-31  
Ставрополь (8652)20-65-13  
Сургут (3462)77-98-35  
Тверь (4822)63-31-35  
Томск (3822)98-41-53  
Тула (4872)74-02-29  
Тюмень (3452)66-21-18  
Ульяновск (8422)24-23-59  
Уфа (347)229-48-12  
Хабаровск (4212)92-98-04  
Челябинск (351)202-03-61  
Череповец (8202)49-02-64  
Ярославль (4852)69-52-93

Единый адрес для всех регионов: [cmn@nt-rt.ru](mailto:cmn@nt-rt.ru) || [www.camille-bauer.nt-rt.ru](http://www.camille-bauer.nt-rt.ru)

использовано с разрешения официального  
дистрибьютора АО «ЮЕ-Интернейшнл»

# KINAX HW730

## Absolute hollow-shaft transmitter for angular position

### For industrial applications in rough environments

KINAX HW730 is a very robust, absolute hollow-shaft transmitter for angular position, which is particularly suited to applications in rough environments due to its unique capacitive measuring principle. It acquires the angular position of a shaft in a non-contact manner and converts it into an impressed direct current proportional to the measured value.

The high mechanical capacity, the robust design, easy assembly, the variety of connection options and free parametrization as well as the large diameter hollow-shaft (up to 30 mm) offer the highest degree of quality and flexibility in application and installation.



### Your customer benefit

#### LOW LIFE-CYCLE COSTS DUE TO:

##### TESTED TOP QUALITY

- Waterproof and dustproof IP67/IP69K
- Suitable for ocean-going vessels acc. GL
- Explosion protection acc. ATEX and IECEx intrinsic safety "ia" (gas and dust) and protection by housing "tb" (dust)

##### SAFE, FREE OF MAINTENANCE

- High accuracy ( $\pm 0.1\%$ )
- Resistant to high mechanical stress due to its robust design and high-quality materials
- High immunity against magnetic fields
- Safe electrical connection and reliability due to spring-type push terminal and reverse voltage protection

##### EASY AND FAST COMMISSIONING

- Hollow-shaft up to 30 mm
- Reliable clamp flange
- 2-wire connection with cable gland or M12 sensor plug
- Free on-site parameterising

### Technical data

#### General

Measured quantity: Angle of rotation  
 Measuring principle: Capacitive method

#### Measuring input

Angle measuring range: Programmable between 0 ... 360°  
 Hollow-shaft diameter:  $\varnothing 30$  mm [1.181"]  
 Reduction of the hollow-shaft- $\varnothing$  by adapter sleeves  
 Starting torque: max. 0.5 Nm [4.248 in-oz]  
 Sense of rotation: Adjustable

#### Measuring output

Output variable  $I_A$ : Load-independent DC current, proportional to the input angle  
 Standard range: 4 ... 20 mA, 2-wire protected against wrong polarity

Power supply:

Standard NEx:  
 nominal voltage 24 VDC  $\begin{matrix} +30\% \\ -50\% \end{matrix}$

Explosion protection intrinsic ia:  
 input voltage  $U_i$ : 12 ... 30VDC  
 max. input current  $I_i$ : 160mA  
 max. input power  $P_i$ : 1W  
 max. internal capacitance  $C_i$ : 22nF  
 max. internal inductance  $L_i$ : 7.3  $\mu$ H

Explosion prevention (Protection by enclosure) tb:  
 nominal voltage 24 VDC  $\begin{matrix} +30\% \\ -50\% \end{matrix}$

Response time:  
 External resistance:  
 (load)

< 3.5 ms  

$$R_{\text{ext.max.}} [\text{k}\Omega] = \frac{H [\text{V}]-12\text{V}}{I_A [\text{mA}]}$$

H = Power supply  
 $I_A$  = Output signal end value

# KINAX HW730

## Absolute hollow-shaft transmitter for angular position

### Accuracy data

Basic accuracy:  $\pm 0.1\%$  at  $360^\circ$

Accuracy cut lower angle ranges:

90°	60°	30°
$\pm 0.22\%$	$\pm 0.29\%$	$\pm 0.53\%$

Additional errors (cumulative):

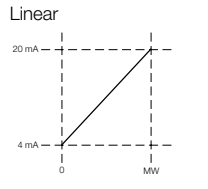
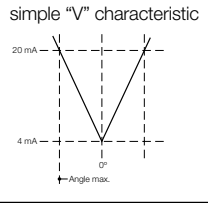
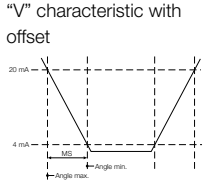
Output characteristic	Definition	Additional error
	Programmed Angle max. = MW Angle min. = $0^\circ$	$f_{Add} = \left( \frac{0.14^\circ}{MW} \times 100 - 0.04 \right)$ $[f_{Add}] = \%$
	ex. at $90^\circ$ : $f = f_{Add} + f_{Abs} = 0.12\% + 0.1\% = 0.22\%$	
	Programmed Angle max. = MW Angle min. = $0^\circ$	$f_{Add} = \left( \frac{0.14^\circ}{MW} \times 100 - 0.04 \right)$ $[f_{Add}] = \%$
	$MS = (\text{angle max.}) - (\text{angle min.})$ angle max. = $\pm$ final angle angle min. = $> 0^\circ$	$f_{Add} = \left( \frac{0.14^\circ}{MW} \times 100 - 0.04 \right)$ $[f_{Add}] = \%$

Resolution:  $\pm 0.1^\circ$  at  $360^\circ$

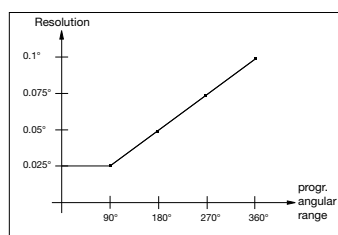

Reproducibility:  $< 0.1^\circ$

Influence of temperature output current (-40...+85°C):  
[-40 ... +185°F]

$\pm 0.04\%$  / 10K

### Installation data

Material: Aluminium AW-6023 T6 anodized

Mounting position: Any

Connections: 2-pin spring-type terminal block or sensor plug connector metal (M12 x 1 / 4 poles / only for NEX version)

Weight: Approx. 820 g

### Regulations

Spurious radiation: EN 61000-6-3

Immunity: EN 61000-6-2

Degree of pollution: 2

Admissible common-mode voltage: 100 V AC, CAT II

Test voltage: 750 V DC, 1 min.  
All connections against housing

Housing protection: IP 67 acc. to EN 60 529  
IP 69k acc. to EN 40 050-9

### Environmental conditions

Climatic rating: Standard (NEx):  
Temperature  $-40 \dots +85^\circ\text{C}$   
[-40 ... +185°F]  
Rel. humidity  $\leq 95\%$  non-condensing

Explosion protection:  
Temperature  $-40 \dots +75^\circ\text{C}$   
[-40 ... +158°F]  
Rel. humidity  $\leq 95\%$  non-condensing

Vibration resistance:  $\leq 100 \text{ m/s}^2 / 10 \dots 500 \text{ Hz}$   
according to EN 60068-2-6

Shock resistance:  $1000 \text{ m/s}^2 / 11 \text{ ms}$   
according to EN 60068-2-27

Transportation and storage temperature:  $-40 \dots +85^\circ\text{C}$  [-40° ... +185°F]

### Operation in potentially explosive environments:

Gas explosion prevention: Labeling: Ex ia IIC T4 Gb

Conform to standard: ATEX:  
EN 60079-0:2009  
EN 60079-11:2007

IECEX:  
IEC 60079-0:2011  
IEC 60079-11:2011-06

Type of protection: ia  
Temperature class: T4

Group according to EN60079-01:2009: II

Dust explosion prevention: Labeling: Ex ia IIIC T80°C Db  
or Ex tb IIIC T80°C Db

Conform to standard: ATEX:  
EN 60079-0:2009  
EN 60079-11:2007  
EN 61241-31:2009

IECEX:  
IEC 60079-0:2011  
IEC 60079-11:2011-06  
IEC 61241-31:2008

Type of protection: ia  
or tb (Protection by enclosure)

max. surface temperature:  $80^\circ\text{C}$

Group according to EN60079-01:2009: III

# KINAX HW730

## Absolute hollow-shaft transmitter for angular position

### Dimensional drawing

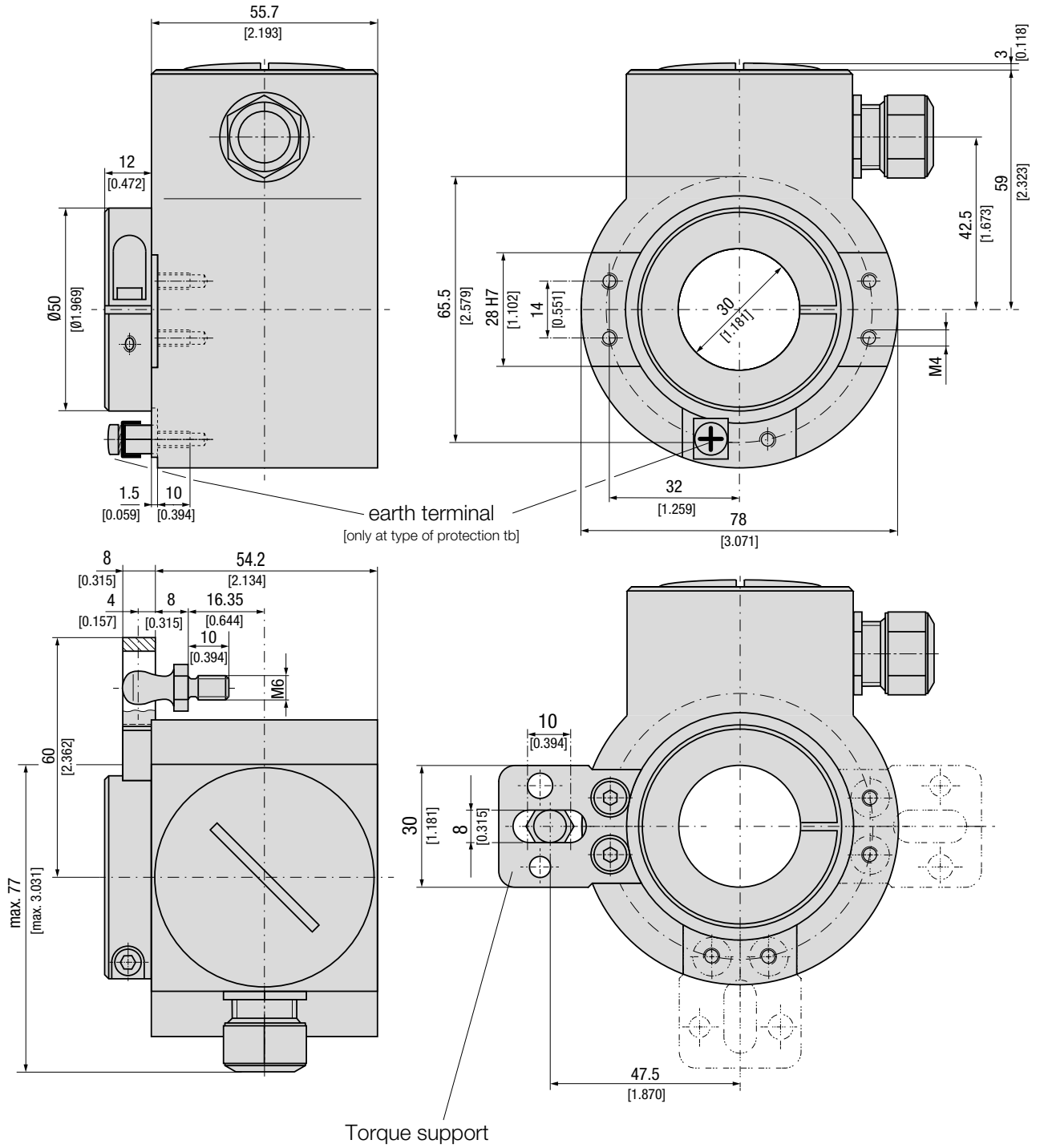

# KINAX HW730

## Absolute hollow-shaft transmitter for angular position

### Programming

Mounting example

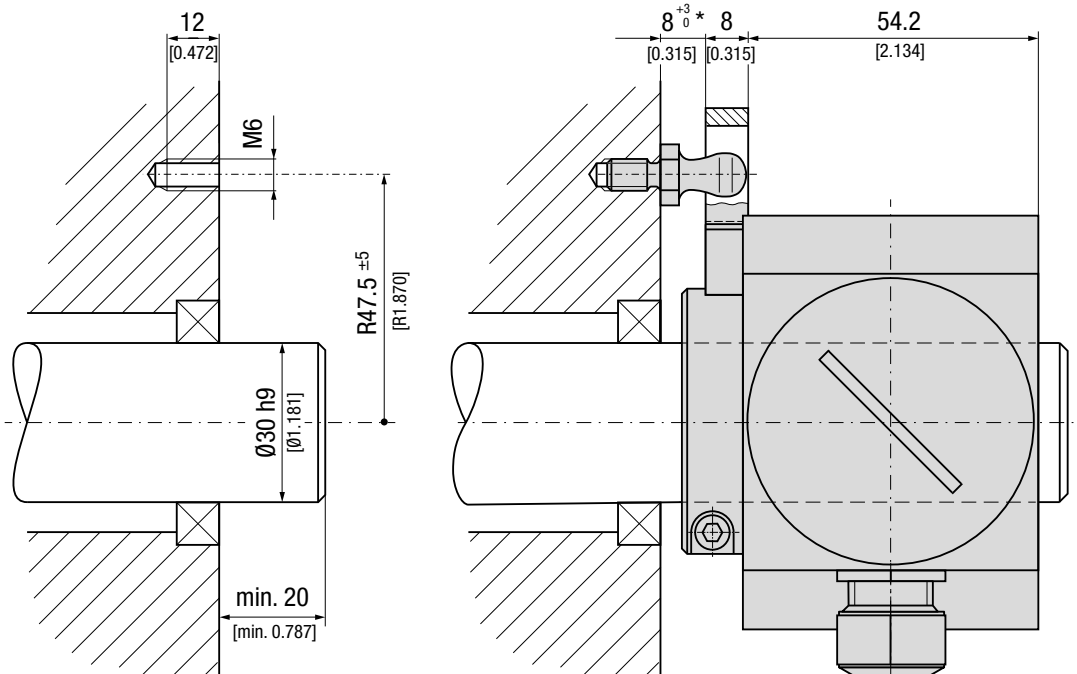

\* Can be increased with spacer bolts.

### Electrical connections

The electrical wires are connected to the transmitter via an M12 x 1 / 4-pole plug connector (only in the non-Ex variant) or an M16 x 1.5 cable gland. The cable gland version is connected according to the connection diagram via a spring-type push terminal. The Ex variant may only be used with the threaded cable connection supplied.

Permissible cable-Ø: NEx 6-10 mm  
Ex 4-8 mm  
max. conductor cross-section: 2.5 mm<sup>2</sup>

Connection allocation spring-type terminal block

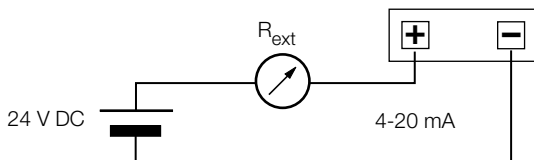

Connection allocation plug (only for non Ex version)

Pin	Plug
1	+
2	-
3	not connected
4	⊥

### Programming

Parameters may be set by keys and DIP switches right at the device. Zero point, span and direction of rotation are set independently of each other. This facilitates the adjustment in commissioning considerably.

In case of an order with a measuring range parameterised at the factory, the zero point may be set by a key while the defined span is preserved.

The factory setting can always be restored in case of maloperation.



# KINAX HW730

## Absolute hollow-shaft transmitter for angular position

### Specification and ordering information

Description	Blocking code	No-go with blocking code	Article No./ Feature
<b>KINAX WT720</b>	<b>Order code 730 - xxxx xxxx xx</b>		730 –
<b>1. Version</b>			
Standard			1
ATEX EX II 2G Ex ia IIC T4 Gb II 2D Ex ia IIIC T80°C Db	A		2
ATEX EX II 2D Ex tb IIIC T80°C Db	A		3
IECEX Ex ia IIC T4 Gb Ex ia IIIC T80°C Db	A		4
IECEX Ex tb IIIC T80°C Db	A		5
<b>2. Angle area mechanically</b>			
Single-Turn (360°)			1
<b>3. Hollow-shaft diameter</b>			
Hollow-shaft 10 mm [0.393"], electrically insulating			1
Hollow-shaft 12 mm [0.472"], electrically insulating			2
Hollow-shaft 16 mm [0.63"], electrically insulating			3
Hollow-shaft 20 mm [0.787"], electrically insulating			4
Hollow-shaft 30 mm [1.181"], electrically insulating			5
Hollow-shaft 18 mm [0.708"], electrically insulating			6
Hollow-shaft 1/2" (12.7 mm), electrically insulating			A
Hollow-shaft 5/8" (15.875 mm), electrically insulating			B
Hollow-shaft 3/4" (19.05 mm), electrically insulating			C
Hollow-shaft 7/8" (22.225 mm) electrically insulating			D
Hollow-shaft 1" (25.4 mm), electrically insulating			E
<b>4. Torque support</b>			
Standard			1
<b>5. Output variable</b>			
Current, 4...20 mA, two wire	B		1
Modbus/TCP with PoE -> in progress	C	A	2
<b>6. Electrical connections</b>			
Gland standard			1
Gland with increased strain relief			2
Sensor plug M12 / 4-pole		A, C	3
Sensor plug M12 / 4-pole d-coded		A, B	4
<b>7. Test certificate</b>			
Without test certificate			0
Test certificate in German			D
Test certificate in English			E
<b>8. Direction of rotation</b>			
Direction of rotation clockwise	J		0
Direction of rotation counter-clockwise	J, G		1
V-characteristic	K, G		2

# KINAX HW730

## Absolute hollow-shaft transmitter for angular position

Description		Blocking code	No-go with blocking code	Article No./ Feature
<b>KINAX WT720</b>		<b>Order code 730 - xxxx xxxx xx</b>		730 -
<b>9. Measuring range</b>				
Basic configuration (linear, 0 ... 360°)			K, G	0
[°angle], 0...end value:		Switching point:	K C	9
V-characteristic [± ° angle]	vmax1:	vmin1:	J, C	Z
	vmax2:	vmin2:		
<b>10. Climatic rating / Marine version</b>				
Standard				0
Version GL (Germanischer Lloyd)				G

### Accessories

Article	Article-Nr.
Plug connector for M12 sensor plug, 5 poles	168 105
Torque support set HW730	169 749
Adapter sleeve HW730 Ø 10mm	168 874
Adapter sleeve HW730 Ø 12 mm	168 882
Adapter sleeve HW730 Ø 16 mm	168 907
Adapter sleeve HW730 Ø 18 mm	171 976
Adapter sleeve HW730 Ø 20 mm	168 915
Adapter sleeve HW730 Ø 1/2" (12.7 mm)	171 984
Adapter sleeve HW730 Ø 5/8" (15.875 mm)	171 992
Adapter sleeve HW730 Ø 3/4" (19.05 mm)	172 007
Adapter sleeve HW730 Ø 7/8" (22.225 mm)	172 015
Adapter sleeve HW730 Ø 1" (25.4 mm)	172 023

### Scope of delivery

- 1 Hollow-shaft transmitter for angular position (according to Order)
- 1 Torque support set HW730 (169 749)
- 1 Operating Instruction german, english, french (157 835)

### Approvals

Approval	Identification
Explosion protection according to IECEx	Ex ia IIC T4 Gb Ex ia IIIC T80°C Db Ex tb IIIC T80°C Db
Explosion protection according to ATEX	Ex II 2G Ex ia IIC T4 Gb Ex II 2D Ex ia IIIC T80°C Db Ex II 2D Ex tb IIIC T80°C Db
Germanischer Lloyd	D, H, EMC1

You find power supply units for KINAX HW730 in our process instrumentation product range.

SINEAX B812	SINEAX B811
1-channel power supply unit	1-channel power supply unit
to feed 2-wire transmitters	

CAMILLE BAUER

**По вопросам продажи и поддержки обращайтесь:**

**Архангельск** (8182)63-90-72  
**Астана** (7172)727-132  
**Астрахань** (8512)99-46-04  
**Барнаул** (3852)73-04-60  
**Белгород** (4722)40-23-64  
**Брянск** (4832)59-03-52  
**Владивосток** (423)249-28-31  
**Волгоград** (844)278-03-48  
**Вологда** (8172)26-41-59  
**Воронеж** (473)204-51-73  
**Екатеринбург** (343)384-55-89  
**Иваново** (4932)77-34-06  
**Ижевск** (3412)26-03-58  
**Казань** (843)206-01-48

**Калининград** (4012)72-03-81  
**Калуга** (4842)92-23-67  
**Кемерово** (3842)65-04-62  
**Киров** (8332)68-02-04  
**Краснодар** (861)203-40-90  
**Красноярск** (391)204-63-61  
**Курск** (4712)77-13-04  
**Липецк** (4742)52-20-81  
**Магнитогорск** (3519)55-03-13  
**Москва** (495)268-04-70  
**Мурманск** (8152)59-64-93  
**Набережные Челны** (8552)20-53-41  
**Нижний Новгород** (831)429-08-12  
**Новокузнецк** (3843)20-46-81

**Новосибирск** (383)227-86-73  
**Омск** (3812)21-46-40  
**Орел** (4862)44-53-42  
**Оренбург** (3532)37-68-04  
**Пенза** (8412)22-31-16  
**Пермь** (342)205-81-47  
**Ростов-на-Дону** (863)308-18-15  
**Рязань** (4912)46-61-64  
**Самара** (846)206-03-16  
**Санкт-Петербург** (812)309-46-40  
**Саратов** (845)249-38-78  
**Севастополь** (8692)22-31-93  
**Симферополь** (3652)67-13-56  
**Смоленск** (4812)29-41-54

**Сочи** (862)225-72-31  
**Ставрополь** (8652)20-65-13  
**Сургут** (3462)77-98-35  
**Тверь** (4822)63-31-35  
**Томск** (3822)98-41-53  
**Тула** (4872)74-02-29  
**Тюмень** (3452)66-21-18  
**Ульяновск** (8422)24-23-59  
**Уфа** (347)229-48-12  
**Хабаровск** (4212)92-98-04  
**Челябинск** (351)202-03-61  
**Череповец** (8202)49-02-64  
**Ярославль** (4852)69-52-93

**Единый адрес для всех регионов: [cmn@nt-rt.ru](mailto:cmn@nt-rt.ru) || [www.camille-bauer.nt-rt.ru](http://www.camille-bauer.nt-rt.ru)**

**PROCESS CONTROL ENGINEERING**



**ANGULAR POSITION ENGINEERING**



**HEAVY CURRENT ENGINEERING**

