

Трансмиситтер углового положения KINAX WT717

Архангельск (8182)63-90-72
Астана (7172)727-132
Астрахань (8512)99-46-04
Барнаул (3852)73-04-60
Белгород (4722)40-23-64
Брянск (4832)59-03-52
Владивосток (423)249-28-31
Волгоград (844)278-03-48
Вологда (8172)26-41-59
Воронеж (473)204-51-73
Екатеринбург (343)384-55-89
Иваново (4932)77-34-06
Ижевск (3412)26-03-58
Казань (843)206-01-48

Калининград (4012)72-03-81
Калуга (4842)92-23-67
Кемерово (3842)65-04-62
Киров (8332)68-02-04
Краснодар (861)203-40-90
Красноярск (391)204-63-61
Курск (4712)77-13-04
Липецк (4742)52-20-81
Магнитогорск (3519)55-03-13
Москва (495)268-04-70
Мурманск (8152)59-64-93
Набережные Челны (8552)20-53-41
Нижний Новгород (831)429-08-12
Новокузнецк (3843)20-46-81

Новосибирск (383)227-86-73
Омск (3812)21-46-40
Орел (4862)44-53-42
Оренбург (3532)37-68-04
Пенза (8412)22-31-16
Пермь (342)205-81-47
Ростов-на-Дону (863)308-18-15
Рязань (4912)46-61-64
Самара (846)206-03-16
Санкт-Петербург (812)309-46-40
Саратов (845)249-38-78
Севастополь (8692)22-31-93
Симферополь (3652)67-13-56
Смоленск (4812)29-41-54

Сочи (862)225-72-31
Ставрополь (8652)20-65-13
Сургут (3462)77-98-35
Тверь (4822)63-31-35
Томск (3822)98-41-53
Тула (4872)74-02-29
Тюмень (3452)66-21-18
Ульяновск (8422)24-23-59
Уфа (347)229-48-12
Хабаровск (4212)92-98-04
Челябинск (351)202-03-61
Череповец (8202)49-02-64
Ярославль (4852)69-52-93

Единый адрес для всех регионов: cmn@nt-rt.ru || www.camille-bauer.nt-rt.ru

использовано с разрешения официального
дистрибьютора АО «ЮЕ-Интернейшнл»

KINAX WT717

Programmable transmitter for angular position

For industrial applications in rough environments

KINAX WT717 is a robust, programmable angular position transmitter, which is particularly suited to applications in rough environments due to its unique capacitive measuring principle. It acquires the angular position of a shaft in a non-contact manner and converts it into an impressed direct current proportional to the measured value.

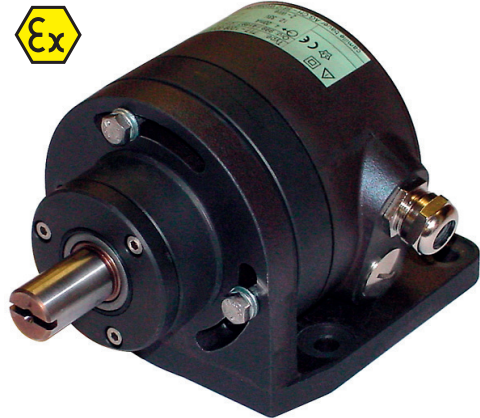

Your customer benefit

LOW LIFE-CYCLE COSTS DUE TO:

TESTED TOP QUALITY

- Capacitive Measuring principle
- Explosion protection acc. ATEX and IECEx intrinsic safety "ia" (gas)

SAFE, FREE OF MAINTENANCE

- 4...20mA analog output signal with 2-wire connection
- Resistant to high mechanical stress due to its robust design and high-quality materials
- High immunity against magnetic fields

EASY AND FAST COMMISSIONING

- No wear, low annual maintenance
- Measuring range, sense of rotation, characteristic and switch point can be parameterised via programming software
- Measured value simulation already during installation is possible

Technical data

General

Measured quantity: Angle of rotation
 Measuring principle: Capacitive method

Measuring input

Angle measuring range: 0...≥ 5 to 0... ≤ 350°(without gear)
 0...1600 turns (with gear)
 Drive shaft diameter: Ø 19 mm [0.748"], Ø 12 mm [0.472"]
 Starting torque: max. 0.25 Nm [35.402 in-oz]
 Sense of rotation: clockwise or counter-clockwise

Measuring output

Output variable I_A : Load-independent DC current, proportional to the input angle
 Zero point variation: approx. ± 5 %
 Final value variation: approx. + 5 %
 Current limitation: I_A max. 40 mA
 Standard range: 4...20 mA, wire connection

Power supply:

Standard (Non-Ex):
 input voltage U_i : 12...33 V
 Explosion protection intrinsic ia:
 input voltage U_i : 12 ... 30 VDC
 max. input current I_i : 160 mA
 max. input power P_i : 1 W
 max. internal capacitance C_i : 6.6 nF
 max. internal inductance L_i : is negligible

Residual ripple in output current:

0.3 % p.p.

Response time:

< 5 ms

External resistance: (load)

$$R_{\text{ext max.}} [\text{k}\Omega] = \frac{H [\text{V}] - 12 \text{ V}}{I_A [\text{mA}]}$$

H = Power supply
 I_A = Output signal end value

Accuracy data

Basic accuracy: 0.5 % with characteristic linear
 Adjustments 350° version
 measuring range > 50...350°
 characteristic linear
 50° version
 measuring range ≥ 10...50°
 characteristic linear

KINAX WT717

Programmable transmitter for angular position

Additional errors (cumulative):

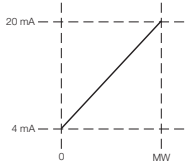
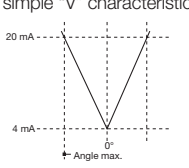
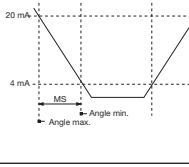
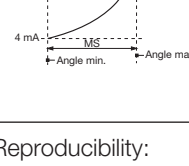
Characteristic	Definition	Additional error
	Programmed Angle max. = MW Angle min. = 0° $[f_{Add}] = \%$	Device version 350°: $f_{Add} = \left(\frac{0.18^\circ}{MW} \times 100 - 0.05 \right)$ Device version 50°: $f_{Add} = \left(\frac{0.05^\circ}{MW} \times 100 - 0.05 \right)$ ex. with MW=180°: $f = f_{Add} + f_{Abs} = 0.05 \% + 0.5 \% = 0.55 \%$
	Programmed Angle max. = MW Angle min. = 0° $[f_{Add}] = \%$	Device version 350°: $f_{Add} = \left(\frac{0.18^\circ}{MW} \times 100 \right)$ Device version 50°: $f_{Add} = \left(\frac{0.05^\circ}{MW} \times 100 \right)$
	$MS = (\text{angle max.}) - (\text{angle min.})$ Angle max. = ± final angle Angle min. = > 0° $[f_{Add}] = \%$	Device version 350°: $f_{Add} = \left(\frac{0.25^\circ}{MS} \times 100 \right)$ Device version 50°: $f_{Add} = \left(\frac{0.09^\circ}{MS} \times 100 \right)$
	$MS = (\text{angle max.}) - (\text{angle min.})$ $[f_{Add}] = \%$	Device version 350°: $f_{Add} = \left(\frac{0.25^\circ}{MS} \times 100 \right)$ Device version 50°: $f_{Add} = \left(\frac{0.09^\circ}{MS} \times 100 \right)$

Reproducibility: < 0.2 %
 Influence of temperature
 output current
 (-40...+70 °C):
 [-40 ... +158 °F] ± 0.2 % / 10 K

Installation data

Housing: Steel (finish QPQ) standard
 High-grade steel 1.4462 sea-water
 Rear (cover): Aluminium (Silafont)
 Mounting position: Any
 Connections: Screwed cable gland metal

There are 2 screw terminals and the programming connection in the rear cover. The screw terminals accept gauges up to 1,5 mm² and are accessible after removing the cover.

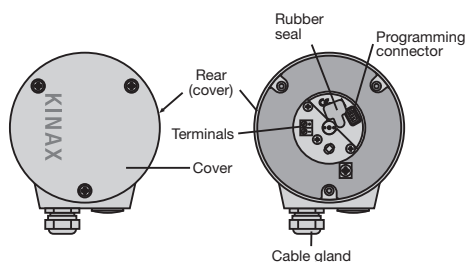

Permissible static load on the shaft:

Max. 1000 N (radial)
 Max. 500 N (axial)

If subjected to vibration the shaft load should be as low as possible to ensure optimum life of the bearing

Bearing play influence
 Weight:

± 0.1 %
 Approx. 2.9 kg (without additional gear)
 Approx. 3.9 kg (with additional gear)
 every 0.5 kg for foot or flange

Regulations

Spurious radiation: EN 61000-6-3
 Immunity: EN 61000-6-2
 Test voltage: 750 V DC, 50 Hz, 1 min.
 All connections against housing

 Admissible common-mode voltage: 100 V AC, 50 Hz
 Impulse voltage withstand: 1 kV, 1.2/50 μs, 0.5 Ws, CAT II
 Housing protection: IP 66 acc. to EN 60 529

Environmental conditions

Climatic rating: Standard (NEx):
 Temperature -25 ... +70 °C
 [-13 ... +158 °F]
 Rel. humidity ≤ 90 % non-condensing
Version with improved climatic rating
 Temperature -40 to +70 °C
 [-40...158 °F]
 Annual mean relative humidity ≤ 95 %

Ex version

Max. performance	Temperature class		
	Pi	T6	T4
1000 mW	40 °C [104 °F]	55 °C [131 °F]	75 °C [167 °F]
900 mW	44 °C [111 °F]	59 °C [138.2 °F]	75 °C [167 °F]
800 mW	49 °C [120.2 °F]	64 °C [147.2 °F]	75 °C [167 °F]
700 mW	54 °C [129.2 °F]	69 °C [156.2 °F]	75 °C [167 °F]
660 mW	56 °C [132.8 °F]	71 °C [159.8 °F]	75 °C [167 °F]

Permissible vibration:
 (without addit. gear):

0...200 Hz,
 10 g continuous, 15 g for 2 h
 200...500 Hz,
 5 g continuous, 10 g for 2 h
 3 × 50 g every 10 impulses
 in all axes

Shock:

Transportation and storage temperature:

-40 ... +80 °C [-40° ... +176 °F]

KINAX WT717

Programmable transmitter for angular position

Operation in potentially explosive environments:

Gas explosion

prevention: Labeling: Ex ia IIC T6 Gb

Conform to ATEX:
standard: EN 60079-0:2012
EN 60079-11:2012

Type of protection: ia

Temperature class: T6, T5, T4

Group according to
EN 60079-00:2012: II

Dimensional drawing

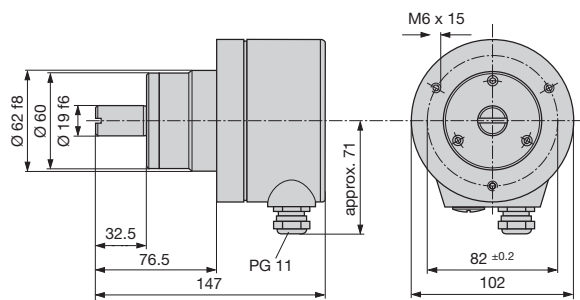

Fig 1. KINAX WT717.

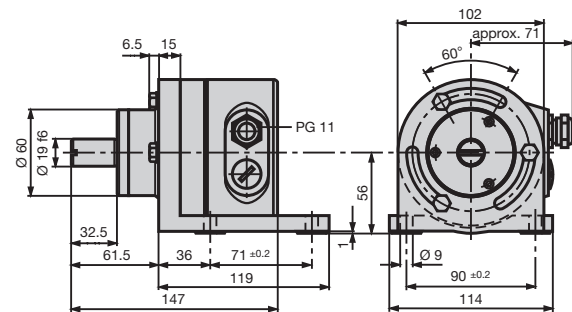

Fig 2. KINAX WT717 with foot.

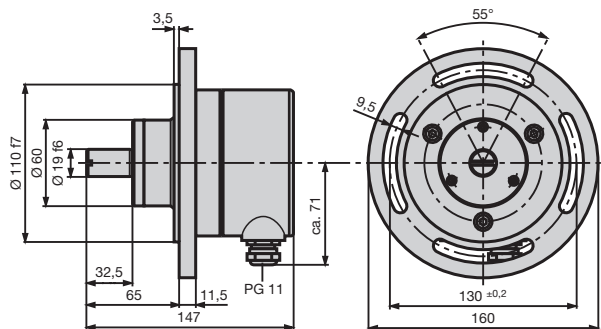

Fig 3. KINAX WT717 with flange.

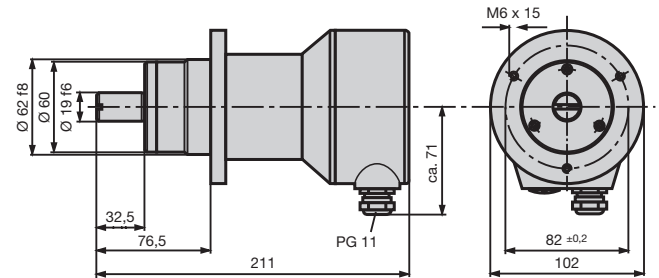

Fig 4. KINAX WT717 with additional gear.

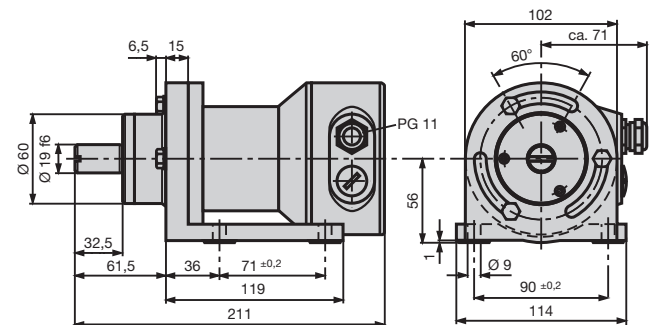

Fig 5. KINAX WT717 with additional gear and foot.

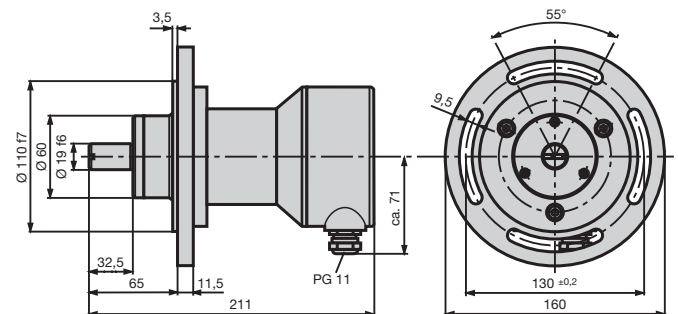

Fig 6. KINAX WT717 with additional gear and flange.

Montage

The six versions of the transmitter differ in their mechanical design. Two of them are intended for mounting directly on the device being measured. The others are equipped with a mounting bracket or a flange. Three M6 screws are needed for the "directly" mounted versions and four M8 nuts and bolts for these "with a bracket" or "with a flange". The screws, respectively nuts and bolts are not supplied, because the required length varies according to the thickness of the mounting surface.

The relationship between the three types of mounting, or more precisely the corresponding cut-out diagrams and the different versions of the transmitter can be seen from table on page 4.

KINAX WT717

Programmable transmitter for angular position

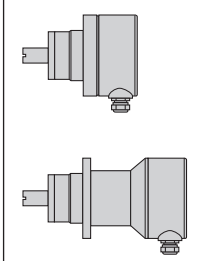
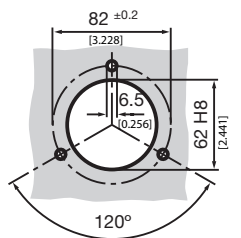
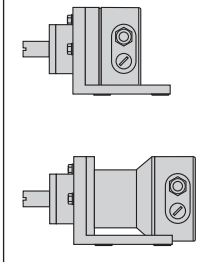
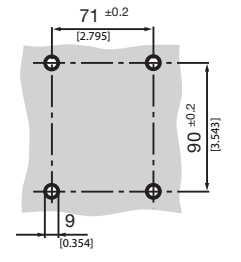
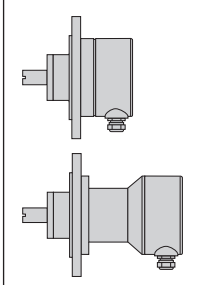
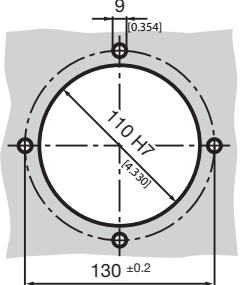
Transmitter versions	Drilling and cut-out diagrams for mounting transmitters ...	
	... directly	
	... with a bracket	
	... with a flange	

Electrical connections

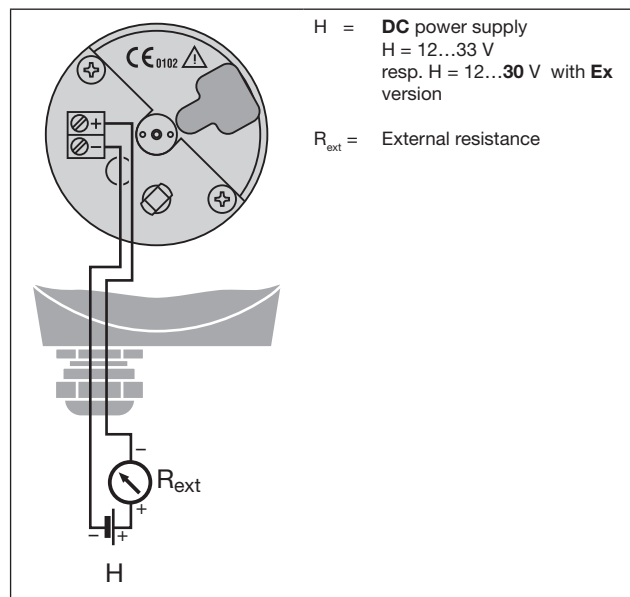

Programming

A PC, the programming cable PK 610 plus ancillary cable and the configuration software 2W2 are required to program the transmitter. (Details of the programming cable and the software are to be found in the separate data sheet: PK 610 Le).

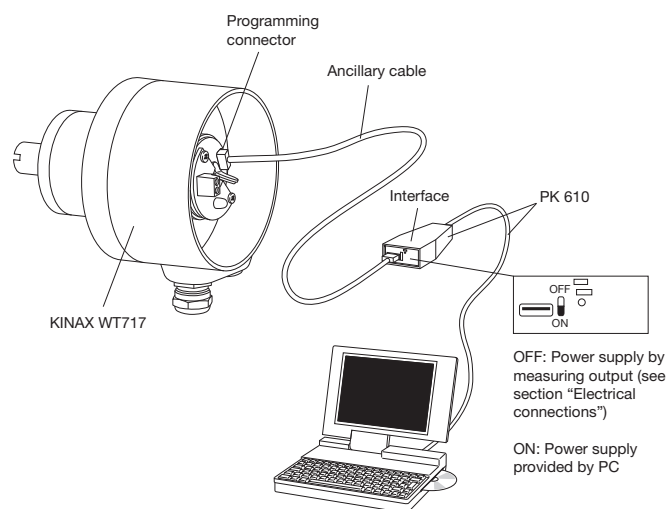

Fig. 7. Example of the set-up for programming a KINAX WT 717 without the power supply. For the case the switch on the interface must be set to "ON".

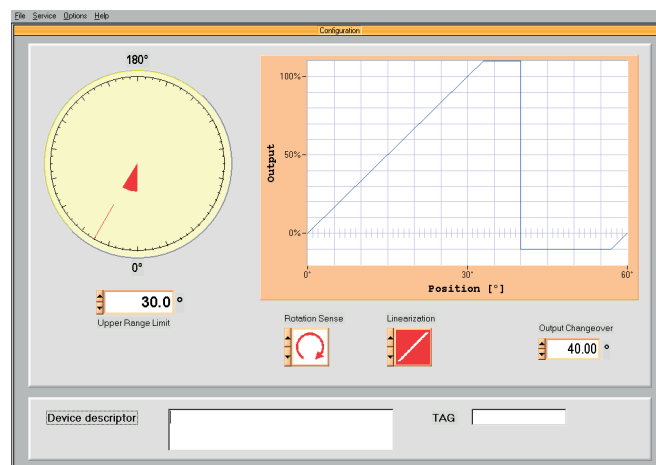

Fig. 8. Print screen example of the menu-controlled programming software.

KINAX WT717

Programmable transmitter for angular position

Table 2: Specification and ordering information

Description	*Blocking code	No-go with blocking code	Article No./ Feature
KINAX WT 717 Order code 717 - xxxx xxxx xxxx x			717 –
Features, Selection			
1. Version of the transmitter			
Standard			1
Ex ia IIC T6, CENELEC/ATEX, measuring output intrinsically safe	K		2
Sea-water resistant version	L	M	3
Sea-water resistant version with additional gear	M		4
Ex ia IIC, CENELEC/ATEX, sea-water resistant version	LK	M	5
2. Mechanical angle range			
Angle range to 50°			1
Angle range > 50 to 350°			2
3. Sense of rotation (in view of drive shaft)			
Sense of rotation clockwise	D		0
Sense of rotation counterclockwise	E		1
For “V” characteristic	F	M	2
Lines 1 and 2: Not possible for transmitters with basic configuration			
4. Measuring range			
Basic configuration, programmed	G	EF	0
[°angle], 0 to final value / switching point:		F	9
Final value ≥ 10 to 50° with angle range ≥ 50°, > 50 to 350° with angle range > 350°			
Switching point > Final value, max. 60° with angle range ≥ 50°, > Final value, max. 360° with angle range > 350° ≥ 105% final value with non-linear characteristic (Lines 1 to 4 in feature 5)			
“V” characteristic [± °angle], min/max.:		DE	Z
Minimal value: > 0			
Maximal value: ≥ 25 with angle range ≥ 50°, Span (max. value – min. value) ≥ 5°; > 25 to 175 with angle range > 350°, span ≥ 25° symmetrical about the center line, e.g. [± angle], min/max.: 15/120 correspond: – 120 to – 15 to 0 to 15 to 120° angle (input) + 20 to 4 to < 4 to 4 to +20 mA (output)			
5. Characteristic of output variable			
Characteristic linear			0
Function X to the power of 1/2		FG	1
Function X to the power of 3/2		FG	2
Function X to the power of 5/2		FG	3
Customized		FG	4
(on inquiry): Give an algorithm or fixed points (23 values in 5% steps from – 5% to 105% of the measuring range, output continuously variable – 10 to 110%)			
Lines 1 to 4: Not possible with “V” characteristic			

KINAX WT717

Programmable transmitter for angular position

Description	*Blocking code	No-go with blocking code	Article No./ Feature
KINAX WT 717	Order code 717 - xxxx xxxx xxxx x		717 -
Features, Selection			
6. Test certificate			
Without test certificate			0
Test certificate in German			D
Test certificate in English			E
7. Marking the system zero position			
System zero position not marked			0
System zero position marked		G	1
8. Climatic rating			
Standard climatic rating			0
Improved climatic rating			1
9. Mounting mode			
Mounting without foot/flange			0
With foot (mounted)			1
With flange (mounted)			2
10. Marine version			
Without			0
11. Vibration resistance			
Standard vibration resistance			0
Increased vibration resistance	H	M	M
12. Additional gear 2:1 to 144:1			
Without additional gear			0
Transformation 2 : 1	J	FHKL	1
Transformation 4 : 1	J	FHKL	2
Transformation 5 : 1	J	FHKL	3
Transformation 6 : 1	J	FHKL	4
Transformation 8 : 1	J	FHKL	5
Transformation 10 : 1	J	FHKL	A
Transformation 12 : 1	J	FHKL	B
Transformation 12,5 : 1	J	FHKL	C
Transformation 15 : 1	J	FHKL	D
Transformation 16 : 1	J	FHKL	E
Transformation 20 : 1	J	FHKL	F
Transformation 22 : 1	J	FHKL	G
Transformation 24 : 1	J	FHKL	H
Transformation 25 : 1	J	FHKL	J
Transformation 30 : 1	J	FHKL	K
Transformation 32 : 1	J	FHKL	L
Transformation 36 : 1	J	FHKL	M

KINAX WT717

Programmable transmitter for angular position

Description	*Blocking code	No-go with blocking code	Article No./ Feature
KINAX WT 717 Order code 717 - xxxx xxxx xxxx x			717 -
Features, Selection			
12. Additional gear 2:1 to 144:1 (Continuation)			
Transformation 40 : 1	J	FHKL	N
Transformation 50 : 1	J	FHKL	O
Transformation 60 : 1	J	FHKL	P
Transformation 64 : 1	J	FHKL	Q
Transformation 72 : 1	J	FHKL	R
Transformation 75 : 1	J	FHKL	S
Transformation 80 : 1	J	FHKL	T
Transformation 100 : 1	J	FHKL	U
Transformation 120 : 1	J	FHKL	V
Transformation 144 : 1	J	FHKL	W
13. Additional gear 150:1 to 1600:1			
Without additional gear			0
Transformation 150 : 1		FHJKL	1
Transformation 160 : 1		FHJKL	2
Transformation 180 : 1		FHJKL	3
Transformation 200 : 1		FHJKL	4
Transformation 240 : 1		FHJKL	A
Transformation 250 : 1		FHJKL	B
Transformation 300 : 1		FHJKL	C
Transformation 330 : 1		FHJKL	D
Transformation 360 : 1		FHJKL	E
Transformation 375 : 1		FHJKL	F
Transformation 400 : 1		FHJKL	G
Transformation 450 : 1		FHJKL	H
Transformation 480 : 1		FHJKL	J
Transformation 500 : 1		FHJKL	K
Transformation 550 : 1		FHJKL	L
Transformation 600 : 1		FHJKL	M
Transformation 660 : 1		FHJKL	N
Transformation 720 : 1		FHJKL	O
Transformation 750 : 1		FHJKL	P
Transformation 800 : 1		FHJKL	Q
Transformation 880 : 1		FHJKL	R
Transformation 900 : 1		FHJKL	S
Transformation 1000 : 1		FHJKL	T
Transformation 1024 : 1		FHJKL	U
Transformation 1200 : 1		FHJKL	V
Transformation 1600 : 1		FHJKL	W

KINAX WT717

Programmable transmitter for angular position

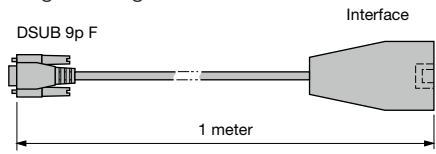
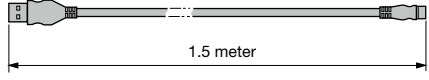

Accessories

Description	Order No.
Programming cable PK 610 	137 887
Ancillary cable 	141 440
Configuration software 2W2 Windows 95 or higherr on CD in German and English In addition, the CD contains all configuration programmes presently available for Camille Bauer products	146 557
Mounting foot	997 182
Mounting flange	997 190
Different bellow couplings	xxx xxx
Different helical and cross-slotted coupling	xxx xxx
Different spring washer coupling	xxx xxx

Scope of delivery

- 1 Transmitter for angular position KINAX WT717 (according to Order)
- 1 Operating instructions in German, French, English and Russian
- 1 Type examination certificate, only with ATEX-approval

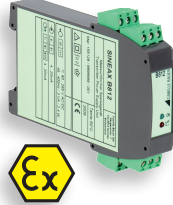
You find power supply units for KINAX WT717 in our process instrumentation product range.

SINEAX B812 1-channel power supply unit	SINEAX B811 1-channel power supply unit
	

Approvals

Approval	Identification
 Explosion protection according to ATEX	Ex II 2G Ex ia IIC T6 Gb

 **CAMILLE BAUER**
Rely on us.

По вопросам продажи и поддержки обращайтесь:

Архангельск (8182)63-90-72
Астана (7172)727-132
Астрахань (8512)99-46-04
Барнаул (3852)73-04-60
Белгород (4722)40-23-64
Брянск (4832)59-03-52
Владивосток (423)249-28-31
Волгоград (844)278-03-48
Вологда (8172)26-41-59
Воронеж (473)204-51-73
Екатеринбург (343)384-55-89
Иваново (4932)77-34-06
Ижевск (3412)26-03-58
Казань (843)206-01-48

Калининград (4012)72-03-81
Калуга (4842)92-23-67
Кемерово (3842)65-04-62
Киров (8332)68-02-04
Краснодар (861)203-40-90
Красноярск (391)204-63-61
Курск (4712)77-13-04
Липецк (4742)52-20-81
Магнитогорск (3519)55-03-13
Москва (495)268-04-70
Мурманск (8152)59-64-93
Набережные Челны (8552)20-53-41
Нижний Новгород (831)429-08-12
Новокузнецк (3843)20-46-81

Новосибирск (383)227-86-73
Омск (3812)21-46-40
Орел (4862)44-53-42
Оренбург (3532)37-68-04
Пенза (8412)22-31-16
Пермь (342)205-81-47
Ростов-на-Дону (863)308-18-15
Рязань (4912)46-61-64
Самара (846)206-03-16
Санкт-Петербург (812)309-46-40
Саратов (845)249-38-78
Севастополь (8692)22-31-93
Симферополь (3652)67-13-56
Смоленск (4812)29-41-54

Сочи (862)225-72-31
Ставрополь (8652)20-65-13
Сургут (3462)77-98-35
Тверь (4822)63-31-35
Томск (3822)98-41-53
Тула (4872)74-02-29
Тюмень (3452)66-21-18
Ульяновск (8422)24-23-59
Уфа (347)229-48-12
Хабаровск (4212)92-98-04
Челябинск (351)202-03-61
Череповец (8202)49-02-64
Ярославль (4852)69-52-93

Единый адрес для всех регионов: cmn@nt-rt.ru || www.camille-bauer.nt-rt.ru

PROCESS CONTROL ENGINEERING



ANGULAR POSITION ENGINEERING



HEAVY CURRENT ENGINEERING

