



Преобразователь частоты SINEAX F534

Архангельск (8182)63-90-72
Астана (7172)727-132
Астрахань (8512)99-46-04
Барнаул (3852)73-04-60
Белгород (4722)40-23-64
Брянск (4832)59-03-52
Владивосток (423)249-28-31
Волгоград (844)278-03-48
Вологда (8172)26-41-59
Воронеж (473)204-51-73
Екатеринбург (343)384-55-89
Иваново (4932)77-34-06
Ижевск (3412)26-03-58
Казань (843)206-01-48

Калининград (4012)72-03-81
Калуга (4842)92-23-67
Кемерово (3842)65-04-62
Киров (8332)68-02-04
Краснодар (861)203-40-90
Красноярск (391)204-63-61
Курск (4712)77-13-04
Липецк (4742)52-20-81
Магнитогорск (3519)55-03-13
Москва (495)268-04-70
Мурманск (8152)59-64-93
Набережные Челны (8552)20-53-41
Нижний Новгород (831)429-08-12
Новокузнецк (3843)20-46-81

Новосибирск (383)227-86-73
Омск (3812)21-46-40
Орел (4862)44-53-42
Оренбург (3532)37-68-04
Пенза (8412)22-31-16
Пермь (342)205-81-47
Ростов-на-Дону (863)308-18-15
Рязань (4912)46-61-64
Самара (846)206-03-16
Санкт-Петербург (812)309-46-40
Саратов (845)249-38-78
Севастополь (8692)22-31-93
Симферополь (3652)67-13-56
Смоленск (4812)29-41-54

Сочи (862)225-72-31
Ставрополь (8652)20-65-13
Сургут (3462)77-98-35
Тверь (4822)63-31-35
Томск (3822)98-41-53
Тула (4872)74-02-29
Тюмень (3452)66-21-18
Ульяновск (8422)24-23-59
Уфа (347)229-48-12
Хабаровск (4212)92-98-04
Челябинск (351)202-03-61
Череповец (8202)49-02-64
Ярославль (4852)69-52-93

Единый адрес для всех регионов: cmn@nt-rt.ru || www.camille-bauer.nt-rt.ru

использовано с разрешения официального дистрибьютора
АО «ЮЕ-Интернейшнл»

SINEAX F534

Transducer for Measuring Frequency

Carrying rail housing P13/70



Application

The transducer **SINEAX F534** (Fig. 1) is intended for frequency measurement. The instrument change the measured value into a proportional **load independent** DC current or DC voltage.

The transducer fulfils all the important requirements and regulations concerning electromagnetic compatibility **EMC** and **Safety** (IEC 1010 resp. EN 61 010). It was developed and is manufactured and tested in strict accordance with the **quality assurance standard** ISO 9001.



Fig. 1. Transducer SINEAX F534 in housing P13/70 clipped onto a top-hat rail.

Features / Benefits

- **Measuring input:** Sine, rectangular or distorted wave forms of nominal input voltage with dominant fundamental waves

Measured variable	Nominal input voltage	Measuring range limits
Frequency	10 to 690 V	10 Hz to 1.5 kHz

- **Measuring output:** Unipolar, bipolar or live zero output variables
- **Measuring principle:** Digital period measurement
- **AC/DC power supply / Universal**
- **Standard as marine version per Lloyd's Register of Shipping**

Overload capacity:

Input quantity	Number of applications	Duration of one application	Interval between two successive applications
$1.2 \times U_N^1$	—	continuously	—
$2 \times U_N^1$	10	1 s	10 s

¹ But max. 264 V with power supply from voltage measuring input

Wave form: Any; fundamental wave only taken into account

Technical data

General

Measured quantity: Frequency
 Measuring principle: Digital period measurement

Measuring input →

Measuring ranges: Selectable between $f_u = 10$ Hz and $f_o = 1500$ Hz
 Min. span: $f_u / (f_o - f_u) < 50$
 Nominal input voltage U_N : 10 ... 230 V or 230 ... 690 V (max. 230 V with power supply from voltage measuring input)
 Own consumption: $< U_N \cdot 1.5$ mA

Measuring output →

Load-independent DC current: 0 ... 1 to 0 ... 20 mA resp. live zero
 1 ... 5 to 4 ... 20 mA ± 1 to ± 20 mA
 Burden voltage: + 15 V, resp. - 12 V
 Load-independent DC voltage: 0 ... 1 to 0 ... 10 V resp. live zero
 0.2 ... 1 to 2 ... 10 V ± 1 to ± 10 V
 Load capacity: Max. 4 mA

SINEAX F534

Transducer for Measuring Frequency

Voltage limit under $R_{\text{ext}} = \infty$:	$\leq 25 \text{ V}$
Current limit under voltage output:	Approx. 30 mA
Residual ripple in output current:	$< 0.5\% \text{ p.p.}$
Nominal value of response time:	4 periods of the measuring frequency
Other ranges:	2, 8 or 16 periods of the measuring frequency

Accuracy (acc. to EN 60 688)

Reference value:	Output span
Basic accuracy:	Class 0.2

Reference conditions

Ambient temperature	15 ... 30 °C
Input voltage	U_{min} to U_{max}
Input frequency	Within the measuring span
Distortion factor	No influence
Power supply	At nominal range
Output burden	ΔR_{ext} max.

Safety

Protection class:	II (protection isolated, EN 61 010)
Housing protection:	IP 40 (test wire, EN 60 529) IP 20, terminals (test finger, EN 60 529)
Contamination level:	2
Overvoltage category:	III
Rated insulation voltage (against earth):	230 resp. 400 V, input 230 V, power supply 40 V, output
Test voltage:	50 Hz, 1 min. acc. to EN 61 010-1 3700 resp. 5550 V, input versus all other circuits as well as outer surface 3700 V, power supply versus output as well as outer surface 490 V, output versus outer surface

Power supply → AC/DC power pack (DC or 50/60 Hz)

Table 1: Rated voltages and permissible variations

Rated voltage	Tolerance
85 ... 230 V DC / AC	DC – 15 ... + 33%
24 ... 60 V DC / AC	AC $\pm 15\%$

Power supply from voltage measuring input:	24 ... 60 V AC or 85 ... 230 V AC, Note: 40 Hz $< f <$ 400 Hz
Option:	Connect to the low tension to terminals 12 and 13 24 V AC or 24 ... 60 V DC
Power consumption:	3 VA

Installation data

Mechanical design:	Housing P13/70
Material of housing:	Lexan 940 (polycarbonate), flammability Class acc. to UL 94, self-extinguishing, non-dripping, free of halogen
Mounting:	For rail mounting
Mounting position:	Any
Weight:	Approx. 0.23 kg

Connecting terminals

Connection element:	Screw-type terminals with indirect wire pressure
Permissible cross section of the connection leads:	$\leq 4.0 \text{ mm}^2$ single wire or $2 \times 2.5 \text{ mm}^2$ fine wire

Environmental conditions

Operating temperature:	– 10 to + 55 °C
Storage temperature:	– 40 to + 70 °C
Relative humidity:	$\leq 75\%$, no dew
Altitude:	2000 m max.
Indoor use statement!	

Ambient tests

EN 60 068-2-6:	Vibration
Acceleration:	$\pm 2 \text{ g}$
Frequency range:	10 ... 150 ... 10 Hz, rate of frequency sweep: 1 octave/minute
Number of cycles:	10, in each of the three axes
EN 60 068-2-27:	Shock
Acceleration:	$3 \times 50 \text{ g}$ 3 shocks each in 6 directions
EN 60 068-2-1/-2/-3:	Cold, dry heat, damp heat
IEC 1000-4-2/-3/-4/-5/-6 EN 55 011:	Electromagnetic compatibility

Germanischer Lloyd

Type approval certificate:	No. 12 261-98 HH
Ambient category:	C
Vibration:	0.7 g

SINEAX F534

Transducer for Measuring Frequency

Output characteristic

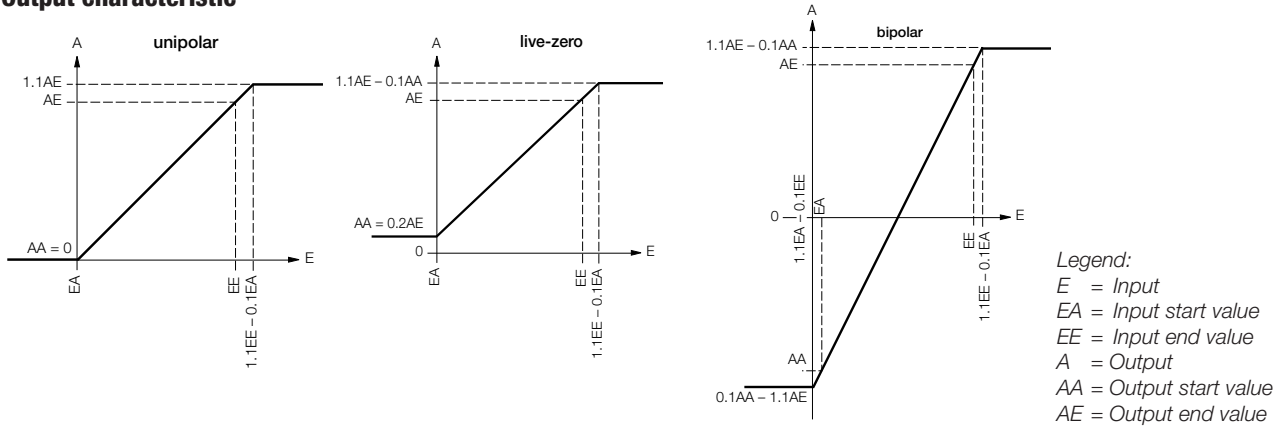

Table 2: Specification and ordering information

Description	*Blocking code	no-go with blocking code	Article No./ Feature
SINEAX F534	Order code 534 - xxxx xx		534 -
Features, Selection			
1. Mechanical design			
Housing P13/70 for rail mounting			4
2. Nominal input voltage			
U_N : 10 ... 230 V			1
U_N : > 230 ... 690 V	A		2
Not possible with power supply from measuring input			
3 phase system: Input voltage = phase to phase voltage			
3. Measuring range			
45 ... 50 ... 55 Hz			1
47 ... 49 ... 51 Hz			2
47.5 ... 50 ... 52.5 Hz			3
48 ... 50 ... 52 Hz			4
58 ... 60 ... 62 Hz			5
Non-standard limit values [Hz]			
Start value $f_a \geq 10$ Hz, end value $f_e \leq 1.5$ kHz			
Min. span $f_a / (f_e - f_a) < 50$			
With power supply from measuring input min. 40 Hz, max. 400 Hz			9
4. Output signal			
0 ... 20 mA			1
4 ... 20 mA			2
Non-standard 0 ... 1.00 to 0 ... < 20, -1.00 ... 0 ... 1.00 to -20 ... 0 ... 20 (symmetrical) [mA]			9
1 ... 5 to < (4 ... 20) ($AA/AE = 1/5$)			
0 ... 10 V			A
Non-standard 0 ... 1.00 to 0 ... < 10, -1.00 ... 0 ... 1.00 to -10 ... 0 ... 10 (symmetrical) [V]			Z
0.2 ... 1 to 2 ... 10 ($AA/AE = 1/5$)			
AA = Output start value, AE = Output end value			
5. Power supply			
85 ... 230 V DC / AC			1
24 ... 60 V DC / AC			2
Internal from measuring input (24 ... 60 V AC)		A	3
Internal from measuring input (85 ... 230 V AC)		A	4
Connect to the low tension 24 V AC / 24 ... 60 V DC			5

SINEAX F534

Transducer for Measuring Frequency

Description	*Blocking code	no-go with blocking code	Article No./ Feature
SINEAX F534	Order code 534 - xxxx xx		534 -
Features, Selection			
6. Response time			
4 periods of the input frequency (standard)			1
2 periods of the input frequency			2
8 periods of the input frequency			3
16 periods of the input frequency			4

* Lines with letter(s) under "no-go" cannot be combined with preceding lines having the same letter under "Blocking code".

Electrical connections

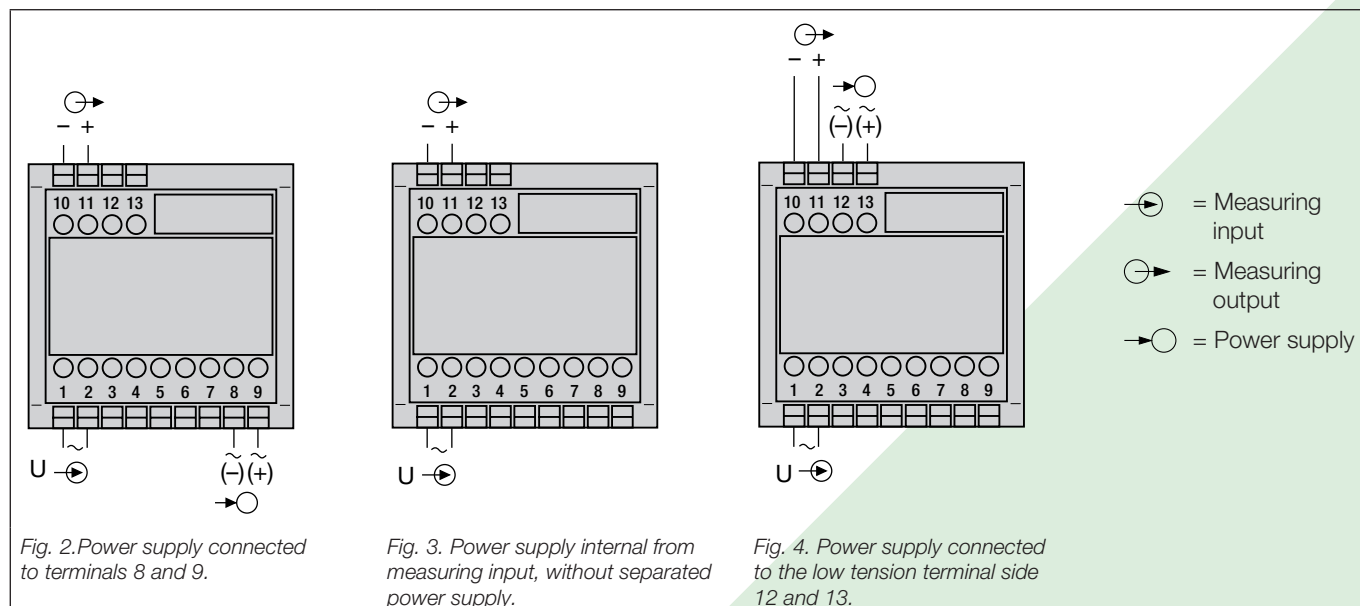

Dimensional drawing

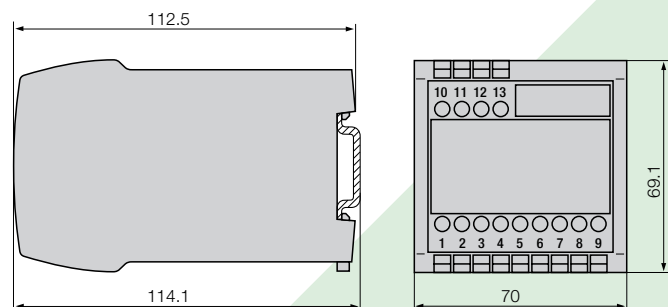

Fig. 5. Housing P13/70 clipped onto a top-hat rail (35 x 15 mm or 35 x 7.5 mm, acc. to EN 50 022).

Standard accessories

1 Operating Instructions in three languages: German, French, English

CAMILLE BAUER
Rely on us.

По вопросам продажи и поддержки обращайтесь:

Архангельск (8182)63-90-72
Астана (7172)727-132
Астрахань (8512)99-46-04
Барнаул (3852)73-04-60
Белгород (4722)40-23-64
Брянск (4832)59-03-52
Владивосток (423)249-28-31
Волгоград (844)278-03-48
Вологда (8172)26-41-59
Воронеж (473)204-51-73
Екатеринбург (343)384-55-89
Иваново (4932)77-34-06
Ижевск (3412)26-03-58
Казань (843)206-01-48



Калининград (4012)72-03-81
Калуга (4842)92-23-67
Кемерово (3842)65-04-62
Киров (8332)68-02-04
Краснодар (861)203-40-90
Красноярск (391)204-63-61
Курск (4712)77-13-04
Липецк (4742)52-20-81
Магнитогорск (3519)55-03-13
Москва (495)268-04-70
Мурманск (8152)59-64-93
Набережные Челны (8552)20-53-41
Нижний Новгород (831)429-08-12
Новокузнецк (3843)20-46-81

Новосибирск (383)227-86-73
Омск (3812)21-46-40
Орел (4862)44-53-42
Оренбург (3532)37-68-04
Пенза (8412)22-31-16
Пермь (342)205-81-47
Ростов-на-Дону (863)308-18-15
Рязань (4912)46-61-64
Самара (846)206-03-16
Санкт-Петербург (812)309-46-40
Саратов (845)249-38-78
Севастополь (8692)22-31-93
Симферополь (3652)67-13-56
Смоленск (4812)29-41-54



Сочи (862)225-72-31
Ставрополь (8652)20-65-13
Сургут (3462)77-98-35
Тверь (4822)63-31-35
Томск (3822)98-41-53
Тула (4872)74-02-29
Тюмень (3452)66-21-18
Ульяновск (8422)24-23-59
Уфа (347)229-48-12
Хабаровск (4212)92-98-04
Челябинск (351)202-03-61
Череповец (8202)49-02-64
Ярославль (4852)69-52-93

Единый адрес для всех регионов: cmn@nt-rt.ru || www.camille-bauer.nt-rt.ru

PROCESS CONTROL ENGINEERING

ANGULAR POSITION ENGINEERING

HEAVY CURRENT ENGINEERING

