



Многофункциональный измеритель мощности A2000

Архангельск (8182)63-90-72
Астана (7172)727-132
Астрахань (8512)99-46-04
Барнаул (3852)73-04-60
Белгород (4722)40-23-64
Брянск (4832)59-03-52
Владивосток (423)249-28-31
Волгоград (844)278-03-48
Вологда (8172)26-41-59
Воронеж (473)204-51-73
Екатеринбург (343)384-55-89
Иваново (4932)77-34-06
Ижевск (3412)26-03-58
Казань (843)206-01-48

Калининград (4012)72-03-81
Калуга (4842)92-23-67
Кемерово (3842)65-04-62
Киров (8332)68-02-04
Краснодар (861)203-40-90
Красноярск (391)204-63-61
Курск (4712)77-13-04
Липецк (4742)52-20-81
Магнитогорск (3519)55-03-13
Москва (495)268-04-70
Мурманск (8152)59-64-93
Набережные Челны (8552)20-53-41
Нижний Новгород (831)429-08-12
Новокузнецк (3843)20-46-81

Новосибирск (383)227-86-73
Омск (3812)21-46-40
Орел (4862)44-53-42
Оренбург (3532)37-68-04
Пенза (8412)22-31-16
Пермь (342)205-81-47
Ростов-на-Дону (863)308-18-15
Рязань (4912)46-61-64
Самара (846)206-03-16
Санкт-Петербург (812)309-46-40
Саратов (845)249-38-78
Севастополь (8692)22-31-93
Симферополь (3652)67-13-56
Смоленск (4812)29-41-54

Сочи (862)225-72-31
Ставрополь (8652)20-65-13
Сургут (3462)77-98-35
Тверь (4822)63-31-35
Томск (3822)98-41-53
Тула (4872)74-02-29
Тюмень (3452)66-21-18
Ульяновск (8422)24-23-59
Уфа (347)229-48-12
Хабаровск (4212)92-98-04
Челябинск (351)202-03-61
Череповец (8202)49-02-64
Ярославль (4852)69-52-93

Единый адрес для всех регионов: cmn@nt-rt.ru || www.camille-bauer.nt-rt.ru

использовано с разрешения официального
дистрибьютора АО «ЮЕ-Интернейшнл»

A2000

Multifunctional Power Meter

3-348-980-03
20/2.15

- Measurement of current, voltage, active, reactive and apparent power, power factor, active and reactive energy, harmonic distortion and harmonics
- 2 additional measuring inputs (optional)
- Precision measured values with error limits of 0.25% for U and I
- Depending upon model, capable of communications with Profibus-DP, LONWORKS interface or RS 485 interface with Modbus RTU and other protocols
- Front panel dimensions: 144 x 144 mm
- Minimal installation depth of less than 60 mm
- Good legibility thanks to the high contrast, 14 mm LED display
- Continuous recording of selected measured values for load profile and statistical purposes (optional)
- Interference recording function with high speed recording of events and pre-event history (optional)
- Electrically isolated current inputs
- Two limit value contacts which can be assigned as desired to measured values



Applications

The measuring instrument is used for the analysis of alternating current systems, in particular where conventional analog measuring instruments included in distribution systems no longer fulfill continuously growing demands. This is especially applicable where harmonic distortion and harmonics are crucial in addition to current, voltage and power.

As a further range of applications, the meter is also capable of eliminating combined use of measuring instruments which are operated simultaneously along with conventional recorders and fault indicators. In combination with current and voltage transformers, the instrument performs the most important measurements required in low and medium-voltage systems.

Analog outputs, limit values and interfaces are available for the monitoring and processing of measured values. A time curve is simultaneously recorded for up to 12 measured values in a fail-safe system if the instrument version with integrated memory is utilized. Important measured values can be monitored continuously over a long period of time, or recording can be triggered for a specified duration by an event. In the case of event controlled recording, it is also possible to record the pre-history which lead up to the event at the same speed. This provides the user with a comprehensive overview of the pre-history which has resulted in an error. The instrument thus fulfills the function of a fault recorder significantly better than conventional paper chart recorders.

Applicable Regulations and Standards

IEC/EN 61010-1 / VDE 0411 Part 1	Safety requirements for electrical equipment for measurement, control and laboratory use
DIN 43864	Current interface for pulse transmission between impulse meters and tariff devices (for pulse output)
DIN EN 61 326 VDE 0843 Part 20	Electrical equipment for measurement, control and laboratory use – EMC requirements
IEC/EN 60529/VDE 0470 Part 1	Protection provided by enclosures (IP code)

Function and Operational Principle

The measuring instrument acquires instantaneous values for star-connected voltages and currents at three-phase electrical systems. If no neutral is available, the instrument automatically creates a virtual neutral point. The speed at which measured values are logged depends upon the respective line frequency. Each measured value is updated 32 times per period, which allows for the acquirement of measuring signals of up to the 15th harmonic.

After these values have been stored to memory, analysis and calculation of data such as delta and star-connected currents and voltages begin, as well as the determination of parameters for power, power factor, energy, harmonic distortion and harmonics. The values are calculated in accordance with DIN 40110 Part 1 and 2.

All calculated values are available to the display, the serial interface, the analog outputs and the limit value monitoring system.

A2000

Multifunctional Power Meter

Data Storage

Up to 12 measured values can be selected for storage to memory. The measuring instrument acquires these measured values once every 300 ms and stores them first to intermediate memory. These values are then averaged in accordance with the selected sampling rate and are stored to permanent memory as mean values. The sampling rate is adjustable from 300 ms to max. 24 hours. Recording is triggered by means of internally selected limit values. The duration of the recording can be set within a range of 1 minute to 31 days. Several events can thus be stored to memory, one after the other. The trigger level which starts the recording can be set to either 0%, 25%, 50% or 75% for the duration of any given recording. This provides the user with an overview of the pre-history of the event which triggered recording, including time and date.

Continuous recording is also possible.

The memory has a capacity for up to 250,000 values. The maximum possible duration of a recording depends upon the number of recorded measured values (1 to 12), and the sampling rate at which they are to be recorded (0.3 s to 24 h).

The memory module is a buffered CMOS RAM. Data integrity is assured for at least 8 years.

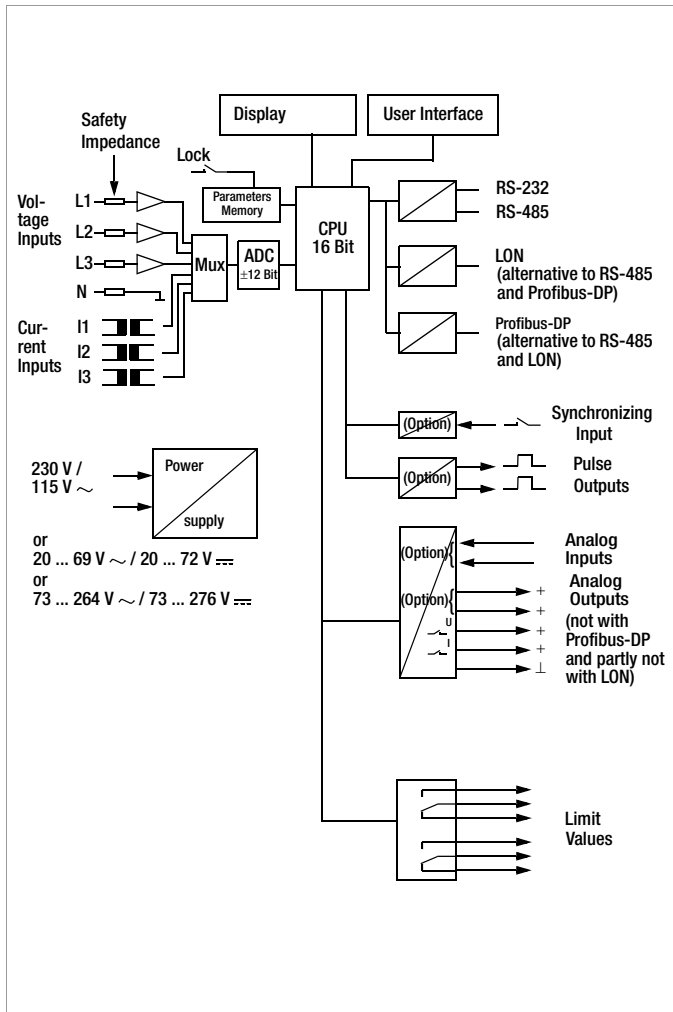
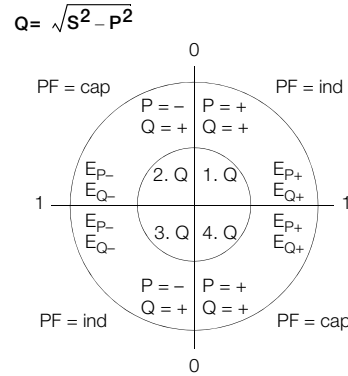

Fig. 1 Schematic Diagram

Representation of Values for Power and Power Factor According to the Selected Parameters Configuration

$d_i n$ = calculation of reactive power per DIN 40110 without + or - sign



$\int u n$ = calculation of reactive power with + or - sign

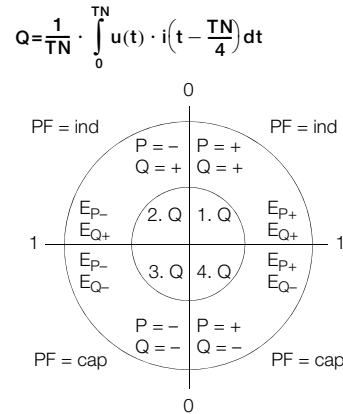

$\int \sigma n P$ = compensating reactive power (reactive power is only produced if current and voltage have different + or - signs)

$$Q = -\frac{2}{TN} \cdot \int_0^{TN} u(t) \cdot i(t) dt$$

for $u(t) \cdot i(t) < 0$

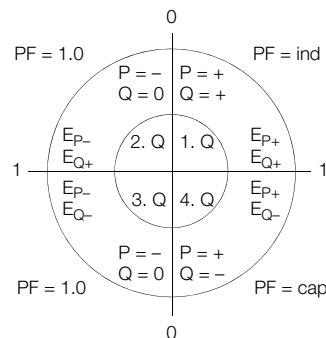

Fig. 2 Values for Power and Power Factor

A2000

Multifunctional Power Meter

Energy Display

The instrument is equipped with eight energy meters for the display of energy values. The following energy values appear at these displays upon shipment from the factory:

- Active energy for phases 1, 2 and 3, as well as for the overall system
- Reactive energy for phases 1, 2 and 3, as well as for the overall system

The meters can be reconfigured to display the following energy values during instrument configuration:

Active energy, high tariff,	import for the overall system
Active energy, low tariff,	import for the overall system
Active energy, high tariff,	export for the overall system
Active energy, low tariff,	export for the overall system
Reactive energy, high tariff,	import for the overall system
Reactive energy, low tariff,	import for the overall system
Reactive energy, high tariff,	export for the overall system
Reactive energy, low tariff,	export for the overall system

Switching from high to low tariff can be accomplished either by means of the synchronization input, an external contact or the data logger's internal clock (only possible if the instrument version with data logger is utilized).

Harmonic Analysis

Harmonic analysis is performed approximately once per second using the 32 averaged, sampled values per signal and mains period. FFT (fast Fourier transformation) provides components up to the 15th harmonic to this end. These are used to calculate the RMS values of the fundamental harmonic (HD 1) and the individual higher harmonics (HD 2 ... 15), as well as total harmonic distortion (THD). These effective values are displayed for the phase currents, and harmonic distortion is displayed for the phase voltages (RMS values with reference to the RMS value for the overall signal).

Due to the fact that the A2000 is not equipped with a special antialiasing filter, distortion in excess of the 17th order may influence measurement results for the higher harmonics.

Serial Interfaces

As standard equipment, the measuring instrument is provided with an RS 232 and an RS 485 interface. Both interfaces use the same protocol, which can be selected as desired.

The GMC device bus per DIN draft 19244, protocol per EN 60870 and Modbus RTU are available. A baud rate of 1200, 2400, 4800, 9600 or 19,200 can be selected. The address can be set within a range of 0 to 254, and parity can be set to even, odd, none or space.

Several measured values are always transmitted with one data word, allowing for especially fast transmission.

In the versions with LONWORKS interface the serial interface RS 485 has been dimensioned for the LONWORKS interface. No additional settings are required for LON.

In the versions with Profibus DP the serial interface RS 485 has been dimensioned for the Profibus DP. The selected address is valid for the RS 232, as well as for the Profibus DP. Addresses greater than or equal to 126 are interpreted as Profibus address 126, and can thus be used to allow for the assignment of an address to the instrument via the Profibus.

The selected baud rate only applies to the RS 232 interface for these instrument versions. The master determines transmission

speed for the Profibus. The A2000 can be operated at the Profibus DP at transmission speeds of up to 12 mega-baud.

LONWORKS Interface

The power meters can be alternatively equipped with a LON interface. In this case, the LONWORKS interface replaces the RS 485. The RS 232 interface is still used for configuring parameters and for reading out the contents of the data memory. The optional data logger can be used with these instrument versions as well, in which case the read-out of recorded data is accomplished via the RS 232 interface.

Profibus DP

All measurement data, except for values stored to the data logger, can be read out via the bus link. Transmission speeds of up to 12 mega-baud are possible. The standard Profibus 9-pin plug is used to connect these measuring instruments to the Profibus DP.

Programming

The instrument can be programmed either with the keys at the front panel or via serial interface. All selected values remain in memory, even if mains failure should occur.

All programmed parameters, except for the limit values, can be protected against inadvertent change with a switch (*LOCK*) at the instrument's rear panel.

This assures that the instrument configuration is not changed during limit value selection.

Alternatively, the *LOCK* switch can be programmed to protect all parameters, including the limit values, against unauthorized modification.

The following values can be set during programming:

Type of Electrical System

- 4-wire unbalanced load or
- 3-wire unbalanced load or
- 3-wire balanced load

The energy meters can be configured to display active and reactive energy for phases L1, L2 and L3, as well as for the overall system, or active and reactive energy for the overall system subdivided into energy import and export, and high and low tariff.

Inputs

Secondary Transformer Current	5 A or 1 A
Primary Transformer Current	1 A
	5 A to 5000 A in 5 A steps to 50000 A in 50 A steps to 150000 A in 500 A steps
Secondary Transformer Voltage	From 100 V to 500 V in 1 V steps
Primary Transformer Voltage	From 100 V to 100 kV in 100 V steps to 800 kV in 1 kV steps
Time Period for Mean Power Values	External via synchronizing input or internally adjustable from 1 to 60 minutes
Synchronizing Input	External, or operation with internal mean value generation, adjustable from 1 to 60 minutes

A2000

Multifunctional Power Meter

Synchronizing Input Function	Synchronization of mean values, tariff switching or external control of the limit values relays	Type of Electrical System	
2 Analog Inputs	<ul style="list-style-type: none"> - Type of input signal standard signal (20 mA/10 V) or Pt1000 - Input range for standard (4 ... 20, 0 ... 20, ± 20, ± 10 mA or 2 ... 10, 0 ... 10, ± 10, ± 5 V) - Scaling of measured value for standard signal (range Lo/Hi) - Displ. dimension at Pt1000 ($^{\circ}\text{C}/^{\circ}\text{F}$) - Offset ($^{\circ}\text{C}/^{\circ}\text{F}$) at Pt1000 - Position of decimal point 	Configuration	4-wire unbalanced (The energy meters display active and reactive energy for phases L1, L2 and L3, as well as for the overall system.)
Outputs		Inputs	
Limit Value Monitoring	<ul style="list-style-type: none"> - Monitored measured values (sources) - Min-max characteristics - Hysteresis - Alarm message storage, on/off - Limit value 	Current	second. transformer current 5 A primary current same as secondary (= ratio 1:1)
2 or 4 Analog Outputs	<ul style="list-style-type: none"> - Measured values which influence the analog outputs - Output range 4 ... 20 mA, 0 ... 20 mA, ± 20 mA, ± 10 mA, 0 ... 10 V, 2 ... 10 V, ± 10 V or ± 5 V - Analog range with lower and upper rang values (independent of measuring range) 	Voltage	secondary phase conductor voltage at the transformer 500 V primary phase conductor voltage same as secondary (= ratio 1:1)
Pulse Outputs for Active or Reactive Energy	<ul style="list-style-type: none"> - Export, Import - Overall energy or energy from the individual phase conductors - Active or reactive energy - Pulse rate: 1 ... 1000 pulses per kWh in steps of 1 1000 ... 5000 pulses per kWh in steps of 10 <p>The same pulse rates can be used for MWh as well.</p>	Synchronizing Pulse	internal, mean value over 15 min.
Serial Interfaces	<p>Either GMC device bus, EN 60870 or Modbus RTU protocol</p> <p>Attention: RS 232 and RS 485 use the same protocol.</p> <p>Addresses with values ranging from 0 to 254 Baud rate: 1200, 2400, 4800, 9600 or 19,200 Parity: even, odd, none or space</p>	Analog Input 1	Type of standard signal Range: 4 ... 20 mA Display: 0 ... 5000
		Analog Input 2	Type of standard signal Range: 4 ... 20 mA Display: 0 ... 2500
		Outputs	
		Limit Value 1	Measured value: I_{L1} set to: 5 A No hysteresis Relay closes when exceeded No storage of alarm messages
		Limit Value 2	Measured value: U_{L1} set to: 240 V No hysteresis Relay closes when exceeded No storage of alarm messages
		Analog Output 1	Meas. value: Overall active power Range: Import 0 ... 2000 W Output Value: 4 ... 20 mA
		Analog Output 2	Meas. value: Overall reactive power Range: Import 0 ... 1000 Var Output Value: 4 ... 20 mA
		Analog Output 3 (optional)	Meas. value: I_{L2} Range: 0 ... 5 A Output Value: 4 ... 20 mA
		Analog Output 4 (optional)	Meas. value: U_{L2} Range: 0 ... 250 V Output Value: 4 ... 20 mA
		Pulse Output 1 (optional)	Meas. value: overall system Active Energy Import 10 pulses per kWh
		Pulse Output 2 (optional)	Meas. value: overall system Active Energy Export 10 pulses per kWh

The measuring instrument is configured with the following parameters at the factory:

All parameters can be subsequently changed by the user.
The encoding switch for securing selected parameters against change is set at the factory to allow for parameter changes.

Serial Interfaces

Address	250
Baud Rate	9600
Protocol	GMC device bus
Parity	even

A2000

Multifunctional Power Meter

Characteristic Values

Measurement Inputs

Voltage Inputs

Phase – Phase	0 ... 500 ... 550 V, 40 ... 70 Hz
Phase – N (ground)	0 ... 290 ... 320 V, 40 ... 70 Hz
Overload	1.2-fold
Intrinsic Impedance	> 290 k Ω
Power Consumption	< 1.1 W

Current Inputs

Measuring Ranges	0 ... 1 ... 1.2 A, 0 ... 5 ... 6 A
Overload	1.4-fold cont. 30 A / 10 s, 100 A / 3 s

Power Consumption < 150 mW

Sampling Rate

32 samples per period and measured value

Measuring Error

Current	NV = nominal value, MV = measured value $\pm (0.25 \% \text{ of NV} + 1 \text{ digit})$ for $MV > 2 \% \text{ of NV}$
Voltage	$\pm (0.25 \% \text{ of NV} + 1 \text{ digit})$
Power, Energy	$\pm (0.5 \% \text{ of NV} + 1 \text{ digit})$
Power Factor	± 0.02 for U, I > 10 % of NV
Frequency	± 0.02 Hz
4-Quadrant Operation	Measurement: import and export, inductive and capacitive

Analog Inputs

MR = Measuring Range

– Standard

Standard signal: (20 mA: 4 ... 20 mA, 0 ... 20 mA, ± 20 mA, ± 10 mA) or (10 V: 2 ... 10 V, 0 ... 10 V, ± 10 V, ± 5 V)
Scaling: (range Lo / Hi)

– Temperature

Pt1000 – scaling: dimension ($^{\circ}\text{C}$, $^{\circ}\text{F}$), offset, decimal point

Signal Frequency	DC
Sampling Interval	640 ms

– Current

Measuring Ranges	0 – 20 mA, 4 – 20 mA, ± 20 mA, ± 10 mA
Load	45 Ω
Measuring Error	$\pm (0.2 \% \text{ MV} + 0,1 \% \text{ of MR})$
Overload permanent	50 mA

– Voltage

Measuring Ranges	0 – 10 V, 2 – 10 V, ± 10 V, ± 5 V
Input Resistance	112 k Ω
Measuring Error	$\pm (0.3 \% \text{ MV} + 0,1 \% \text{ of MR})$
Overload permanent	100 V

– Pt1000 (according to EN 60751)

Connection	2-wire
Measuring Range	185 ... 3905 Ω (–200 ... 850 $^{\circ}\text{C}$)
Measuring Error	$\pm (0.5 \% \text{ MV} + 1 \text{ }^{\circ}\text{K})$

– Display Values

for Standard Signal	
Lower/Upper Range Limit	–1999 ... +9999 configurable
Resolution	depending on range and position of decimal point
at Pt1000	
Lower/Upper Range Limit	–200 ... 860 $^{\circ}\text{C}$ (–328 ... 1580 $^{\circ}\text{F}$)
Resolution	0.1 or 1 $^{\circ}\text{C}/^{\circ}\text{F}$
Offset	adjustable from –100 to +100 $^{\circ}\text{C}$

Synchronizing input

On	short-circuited with $R < 10 \Omega$
Off	open with $R > 10 \text{ M}\Omega$

Interfaces

Interfaces	RS-232 and RS-485 alternatively: RS-232 and LON or RS-232 and Profibus-DP
Baud Rate	1200, 2400, 4800, 9600, 19200 baud
Parity	even, odd, space, no
Protocol for RS-232 and RS-485	selectable: GMC device bus (DIN draft 19244), EN 60870 or Modbus (RTU)

Pulse Outputs

Contact	open collector
Current	ON 10 mA ... 27 mA OFF < 2 mA
External Voltage	8 ... 30 V
Pulse Duration	adjustable: 100 ms ... 800 ms
Interpulse Period	≥ 10 ms

Analog Outputs

Output Quantity	configurable
Current	
Ranges	0 – 20 mA, 4 – 20 mA, ± 20 mA, ± 10 mA
Load	max. 500 Ω
Load Effect	< 0.8 $\mu\text{A} / \Omega$ (0 ... 250 ... 500 Ω)
Resolution	0.1 % of control range
Error Limit	$\pm 0.5 \% \text{ of final value}$

Voltage

Ranges	0 – 10 V, 2 – 10 V, ± 10 V, ± 5 V
Load	< 20 mA
Load Effect	no effect to > 10 K Ω
Resolution	0.1 % of control range
Error Limit	$\pm 1.0 \% \text{ of final value}$

where control range = upper range limit – lower range limit,
e.g. 1200 W = 1500 W – 300 W (freely selectable values)

Relay Outputs

Switching Capacity	$\sim / \dots 250$ V, 2 A, 500 VA / 50 W (nominal load)
Service Life	> 500000 switching cycles

Display

Type	7-Segment LED
Display Color	red
Character Height	13.2 mm
Display Range	
Energy	999999999
Power Factor	1.00
Other Quantities	9999

A2000

Multifunctional Power Meter

Internal Clock

(only for version with data logger, LON or Profibus)

Accuracy	< 2.5 s/day
Power Supply	lithium cell, service life > 8 years

Power Supply

Supply Voltage	
Feature H0	230 V / 115 V $\sim \pm 10\%$, 45 ... 65 Hz
Feature H1	20 ... 69 V $\sim 45...450$ Hz 20 ... 72 V \equiv
Feature H2	73 ... 264 V $\sim 45...450$ Hz 73 ... 276 V \equiv
Feature H3	20 ... 27 V $\sim 45 ... 450$ Hz 20 ... 36 V \equiv
Power Consumption	max. 15 VA

The instrument is not equipped with an integrated circuit breaker.

Therefore, during installation, care should be taken to ensure that

- the building where the instrument is installed includes a circuit breaker,
- the circuit breaker is positioned in close proximity to the instrument and is easily accessible to the operator,
- it is clearly marked as a circuit breaking device for the instrument.

Electrical Safety

Variants	IEC 61010-1 / EN 61010-1
Protection Class	II
Measurement Category	inputs: III, relays: II
Pollution Degree	2
Operating Voltage	300 V \sim / \equiv
Test Voltage	measuring inputs: 3.7 kV
Protection	IEC 60529 / EN 60529
Front Panel	IP 52
Housing	IP 30
Terminals	IP 20

Fuses

The supply circuit is protected by an internally soldered fuse.

Feature H0	T160mA/250V
Feature H1	T1A/250V
Feature H2	T250mA/250V
Feature H3	T1.25A/250V

EMC

Interference Emission/ Interference Immunity	IEC 61326 / EN 61326
---	----------------------

Ambient Conditions

Operating Temp.	0 ... 50 °C
Storage Temp.	- 25 ... 70 °C
Relative Humidity	75%, no condensation allowed

Terminal Assignments

Current Inputs

Connection with 3 Current Transformers
in 3 or 4-Phase Mains System (4L)

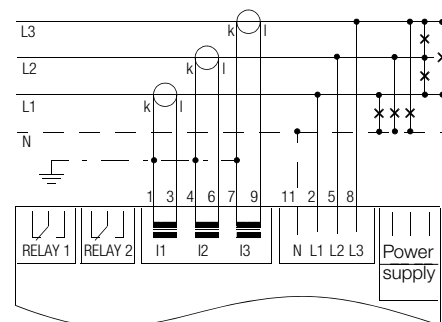

Connection with 2 Current Transformers
in 3-Phase Mains System (3L)

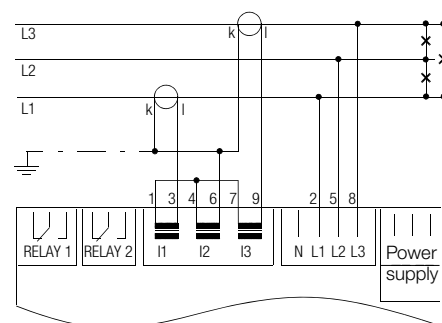

Connection with 1 Current Transformer
in 4-Phase Mains System (identical load, $I_N = 0$)

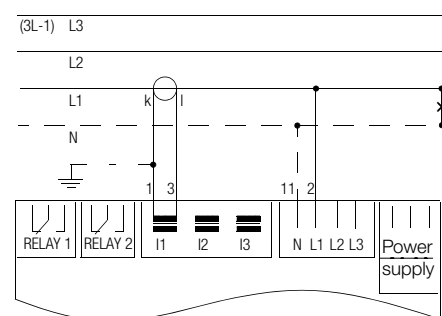

Connection with 1 Current Transformer
in 3-Phase Mains System (identical load)

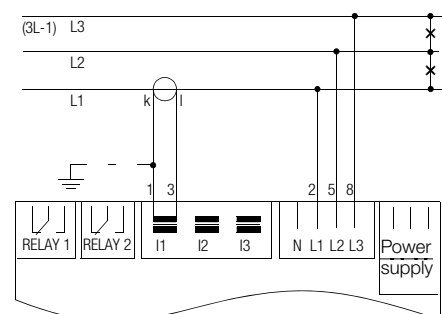

A2000 Multifunctional Power Meter

Terminals

Screw clamps for wires/cords up to 2.5 mm²
and/or two-core wire-end ferrules for 2 x 1.0 mm²

Design with 2 or 4 analog outputs and serial interface RS-232 and RS-485 or LON

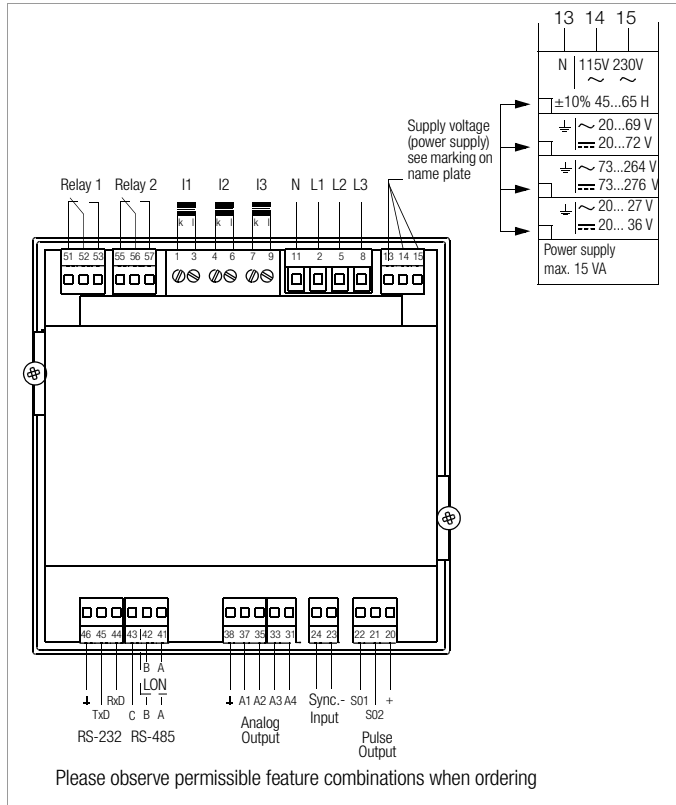

Design with 2 analog inputs and 2 outputs and serial interface RS-232 and RS-485 (Feature A3)

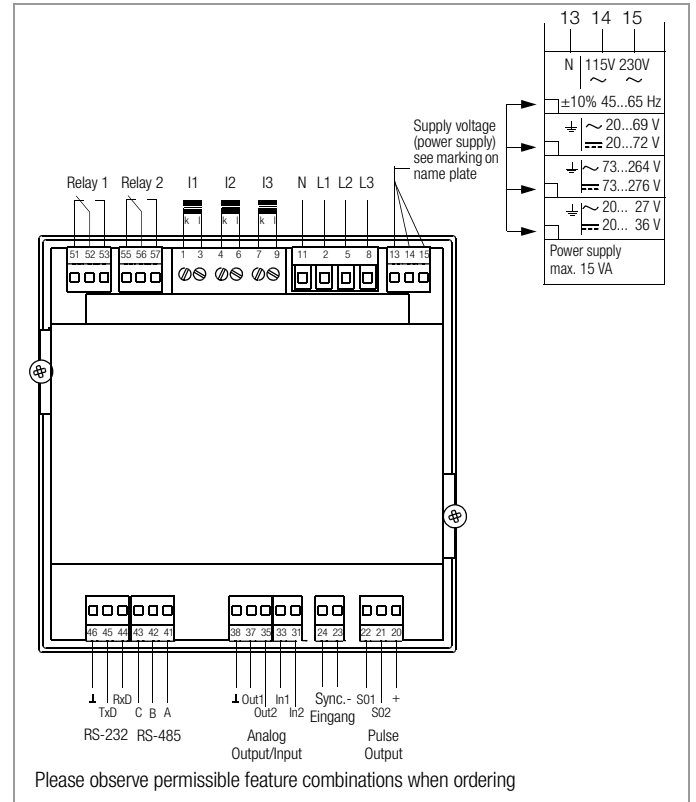

Design with Profibus-DP and RS-232 Serial Interface

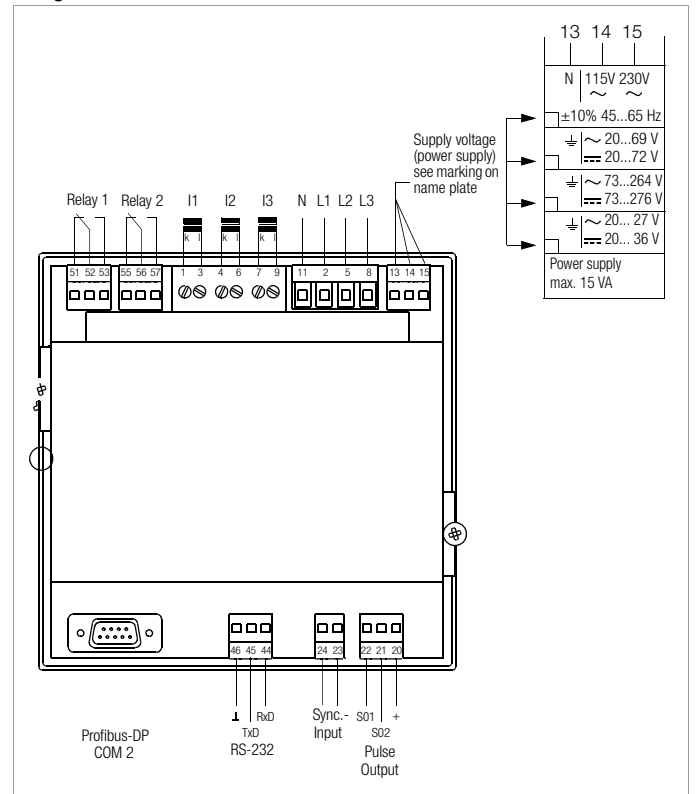

A2000

Multifunctional Power Meter

Mechanical Design

Front dimensions	144 x 144 mm
Panel cutout	138 ⁺¹ x 138 ⁺¹ mm
Bezel height	8 mm
Installation depth	59.1 mm
Weight	1 kg (without packaging)
Mounting	DIN screw clamps
Terminals	Screw clamp terminal blocks

Dimensional Drawing

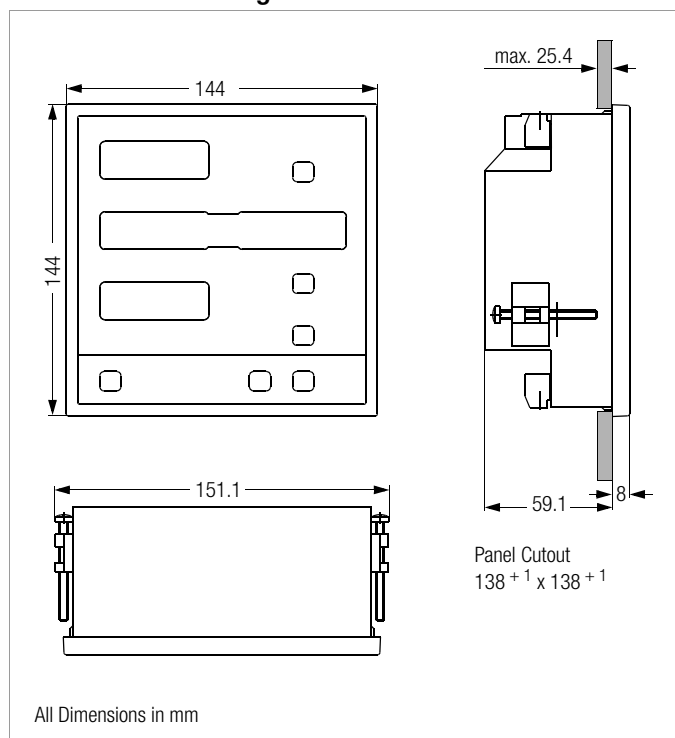

Standard Equipment

Power meters without data memory (without optional data logger):

Measuring instruments without data logger are shipped with operating instructions in German and English.

Power meters with data memory (with optional data logger):

In addition to the measuring instrument and operating instructions in German and English, power meters with data logger also include METRAWin[®]10/A2000 software for download from our homepage and an adapter with a subminiature plug (for connection to a PC via extension cable).

Accessory Software

METRAWin[®]10/A2000

Software for read-out and processing of measured values as they occur, or values from the data logger in the A2000 multifunctional power meter, and for configuring parameters at the A2000.

This software runs under Microsoft Windows XP SP3, Vista SP1, Windows 7 or 8.

- Read-out of measured values from the power meter's data logger
- Continuous recording of measured values over a given period of time
- Display of measured values
 - as a function of time in line recorder format,
 - in tabular form,
 - digitally as individual values or
 - analog as bar graphs
- Freely selectable time intervals
- Identification of curves for the recognition of individual measured value sequences
- Simple, clear parameters configuration for the A2000
- Parameters configurations for frequently recurring setups can be saved to memory
- Measured values can be exported to other Windows programs
- Mathematical functions

Software Description

Data Acquisition and Display

METRAWin[®]10/A2000 provides for an unambiguous display of the contents of the data memory from the A2000. Alternatively, measured values can be continuously queried from the measuring instrument by the software, and stored to a data file.

METRAWin[®]10/A2000 summarizes values from the data logger or online recorded values in tabular form, and documents minimum and maximum values with date and time as well.

All measured values can be plainly represented as a function of time with a y-t graph. The time scale can be expanded or contracted to allow for optimal representation. The cursor can be placed at the corresponding position within the time scale for precision readings.

Measured values can also be displayed digitally. Up to four measured values can be displayed at the monitor simultaneously in digital form.

Instrument Configuration with METRAWin[®]10/A2000

METRAWin[®]10/A2000 plainly displays all of the functions and possible settings included in the power meter in various windows. The desired parameter values are entered to the corresponding fields and are subsequently uploaded to the power meter.

A2000 Multifunctional Power Meter

Order Information

Designation		Configuration Options Article Number / Feature		
		A2000	A2000	A2000
A2000 Multifunctional Power Meter		A2000	A2000	A2000
Serial Interface	with RS-232 and RS-485	L0	—	—
	with LON and RS-232	—	L1	—
	with Profibus-DP and RS-232	—	—	L2
Analog Outputs and Inputs	2 analog outputs	A0	A0	—
	4 analog outputs	A1 ¹⁾	—	—
	2 analog outputs and 2 analog inputs	A3 ^{1) 3)}	—	—
	without analog output	—	—	A2
Data Logger	without data logger	R0	R0	R0
	with data logger	R1 ^{1) 2)}	R1 ¹⁾	R1 ¹⁾
Pulse Output / Synchronizing Input	without pulse output and without synchronizing input	P0	—	P0
	2 pulse outputs and 1 synchronizing input	P1	P1	P1
Supply Voltage	230 / 115 V ~	H0	H0	H0
	20 ... 69 V ~ / 20 ... 72 V ===	H1	H1	H1
	73 ... 264 V ~ / 73 ... 276 V ===	H2	H2	H2
	20 ... 27 V ~ / 20 ... 36 V ===	H3	H3	H3
Manufacturer's Certificate / Test Report	without certificate	U0	U0	U0
	with certificate and test report	U1	U1	U1
Operating Instructions	in print: German and English / on our homepage: German, English, French, Spanish and Italian			
Interface Description	on our homepage: German, English			
Software	METRAwin [®] 10/A2000: on our homepage			

¹⁾ only in combination with Feature P1

²⁾ only in combination with Feature A1

³⁾ only in combination with Feature R1

A2000 Mobile Set

Designation	Feature Combination	Article Number
A2000 Mobile Set	A2000 H0 A0P1R1L0U0	A202A

Accessories for A2000 and A2000 Mobile Set

Designation	Article Number
Adapter (Screw clamp A2000 on 9-pin sub-D for PC) with METRAwin [®] 10/A2000 (software for transmission of meas. values and instrument configuration)	Z305A
Interface cable RS-232, approx. 2 m long	GTZ3241000R0001

Standard Units

The following measuring instruments can be shipped as standard units. Only the article number needs to be indicated.

Designation	Instrument and Features Combination	Article Number
A2000 with 230 V / 115 V ~ supply voltage, with 2 analog outputs, with RS-232 and RS-485 interfaces, with operating instructions, interface descriptions and software	A2000 H0 A0 P0 R0 L0 U0	A2000-V001
A2000 with 230 V / 115 V ~ supply voltage, with 4 analog outputs, with 2 pulse outputs and 1 synchronizing input, with RS-232 and RS-485 interfaces, with operating instructions, interface descriptions and software	A2000 H0 A1 P1 R0 L0 U0	A2000-V002
A2000 with 230 V / 115 V ~ supply voltage, with 4 analog outputs, with 2 pulse outputs and 1 synchronizing input, with data logger, with RS-232 and RS-485 interfaces, with operating instructions, interface descriptions and software	A2000 H0 A1 P1 R1 L0 U0	A2000-V003
A2000 with 230 V / 115 V ~ supply voltage, with 2 analog outputs, with 2 pulse outputs and 1 synchronizing input, with LON and RS-232 interfaces, with operating instructions, interface descriptions and software	A2000 H0 A0 P1 R0 L1 U0	A2000-V004
A2000 with 230 V / 115 V ~ supply voltage, with 2 pulse outputs and 1 synchronizing input, with Profibus-DP and RS-232, with operating instructions, interface descriptions and software	A2000 H0 A2 P1 R0 L2 U0	A2000-V005

По вопросам продажи и поддержки обращайтесь:

Архангельск (8182)63-90-72
Астана (7172)727-132
Астрахань (8512)99-46-04
Барнаул (3852)73-04-60
Белгород (4722)40-23-64
Брянск (4832)59-03-52
Владивосток (423)249-28-31
Волгоград (844)278-03-48
Вологда (8172)26-41-59
Воронеж (473)204-51-73
Екатеринбург (343)384-55-89
Иваново (4932)77-34-06
Ижевск (3412)26-03-58
Казань (843)206-01-48



Калининград (4012)72-03-81
Калуга (4842)92-23-67
Кемерово (3842)65-04-62
Киров (8332)68-02-04
Краснодар (861)203-40-90
Красноярск (391)204-63-61
Курск (4712)77-13-04
Липецк (4742)52-20-81
Магнитогорск (3519)55-03-13
Москва (495)268-04-70
Мурманск (8152)59-64-93
Набережные Челны (8552)20-53-41
Нижний Новгород (831)429-08-12
Новокузнецк (3843)20-46-81

Новосибирск (383)227-86-73
Омск (3812)21-46-40
Орел (4862)44-53-42
Оренбург (3532)37-68-04
Пенза (8412)22-31-16
Пермь (342)205-81-47
Ростов-на-Дону (863)308-18-15
Рязань (4912)46-61-64
Самара (846)206-03-16
Санкт-Петербург (812)309-46-40
Саратов (845)249-38-78
Севастополь (8692)22-31-93
Симферополь (3652)67-13-56
Смоленск (4812)29-41-54



Сочи (862)225-72-31
Ставрополь (8652)20-65-13
Сургут (3462)77-98-35
Тверь (4822)63-31-35
Томск (3822)98-41-53
Тула (4872)74-02-29
Тюмень (3452)66-21-18
Ульяновск (8422)24-23-59
Уфа (347)229-48-12
Хабаровск (4212)92-98-04
Челябинск (351)202-03-61
Череповец (8202)49-02-64
Ярославль (4852)69-52-93

Единый адрес для всех регионов: cmn@nt-rt.ru || www.camille-bauer.nt-rt.ru

PROCESS CONTROL ENGINEERING

ANGULAR POSITION ENGINEERING

HEAVY CURRENT ENGINEERING

