

Программируемый мультипреобразователь SINEAX M561, M562, M563

Архангельск (8182)63-90-72
Астана (7172)727-132
Астрахань (8512)99-46-04
Барнаул (3852)73-04-60
Белгород (4722)40-23-64
Брянск (4832)59-03-52
Владивосток (423)249-28-31
Волгоград (844)278-03-48
Вологда (8172)26-41-59
Воронеж (473)204-51-73
Екатеринбург (343)384-55-89
Иваново (4932)77-34-06
Ижевск (3412)26-03-58
Казань (843)206-01-48

Калининград (4012)72-03-81
Калуга (4842)92-23-67
Кемерово (3842)65-04-62
Киров (8332)68-02-04
Краснодар (861)203-40-90
Красноярск (391)204-63-61
Курск (4712)77-13-04
Липецк (4742)52-20-81
Магнитогорск (3519)55-03-13
Москва (495)268-04-70
Мурманск (8152)59-64-93
Набережные Челны (8552)20-53-41
Нижний Новгород (831)429-08-12
Новокузнецк (3843)20-46-81

Новосибирск (383)227-86-73
Омск (3812)21-46-40
Орел (4862)44-53-42
Оренбург (3532)37-68-04
Пенза (8412)22-31-16
Пермь (342)205-81-47
Ростов-на-Дону (863)308-18-15
Рязань (4912)46-61-64
Самара (846)206-03-16
Санкт-Петербург (812)309-46-40
Саратов (845)249-38-78
Севастополь (8692)22-31-93
Симферополь (3652)67-13-56
Смоленск (4812)29-41-54

Сочи (862)225-72-31
Ставрополь (8652)20-65-13
Сургут (3462)77-98-35
Тверь (4822)63-31-35
Томск (3822)98-41-53
Тула (4872)74-02-29
Тюмень (3452)66-21-18
Ульяновск (8422)24-23-59
Уфа (347)229-48-12
Хабаровск (4212)92-98-04
Челябинск (351)202-03-61
Череповец (8202)49-02-64
Ярославль (4852)69-52-93

Единый адрес для всех регионов: cmn@nt-rt.ru || www.camille-bauer.nt-rt.ru

использовано с разрешения официального дистрибьютора
АО «ЮЕ-Интернейшл»

SINEAX M561 / M562 / M563 with 1, 2 resp. 3 analog outputs Programmable Multi-Transducer for Industry

for the measurement of electrical variables in heavy-current power system



Application

SINEAX M 561/M 562/M 563 (Fig.1) is a programmable transducer with a **RS 232 C** interface. M 561 supervises 1 variable (input) which is available on an analog output signal. Input and output are electrically isolated. M 562 resp. M 563 measure 2 resp. 3 variables simultaneously and generate **2** resp. **3** electrically isolated analog output signals.

The transducers are also equipped with an **RS 232** serial interface to which a PC with the corresponding software can be connected for programming or accessing and executing useful ancillary functions.

The usual methods of connection, the types of measured variables, their ratings, the transfer characteristic for each output etc. are the main parameters that can be programmed.

The ancillary functions include displaying, recording and evaluation of measurements on a PC, the simulation of the outputs for test purposes and a facility for printing nameplates.

The transducer fulfils all the essential requirements and regulations concerning electromagnetic compatibility (**EMC**) and **safety** (IEC 1010 resp. EN 61 010). It was developed and is manufactured and tested in strict accordance with the **quality assurance standard ISO 9001**.

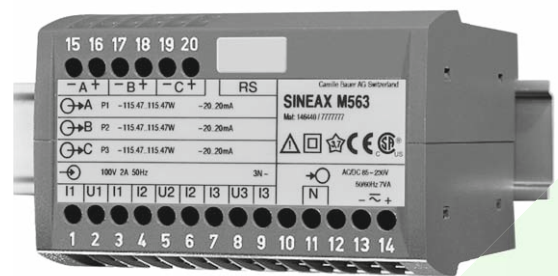

Fig. 1. SINEAX M 563 transducer in housing P20/105 clipped onto a top-hat rail.

Features / Benefits

- Simultaneous measurement of several variables of a heavy-current power system

Measured variables	Nominal input current	Nominal input voltage
Current, voltage (rms), active/reactive/apparent power $\cos\phi$, $\sin\phi$, power factor RMS value of the current with wire setting range (bimetal measuring function) Slave pointer function for the measurement of the RMS value I_B Frequency Average value of the currents with sign of the active power (power system only)	1 to 6 A	57.7 to 400 V (phase-to-neutral) resp. 100 to 693 V (phase-to-phase)

- For all heavy-current power system variables
- Universal analog outputs (programmable)
- Input voltage up to 693 V (phase-to-phase)
- High accuracy: Class 0.2 (U, I) resp. 0.5 (all other quantities)
- Windows software with password protection for programming, data analysis, power system status simulation
- DC-, AC-power pack with wide power supply tolerance / Universal

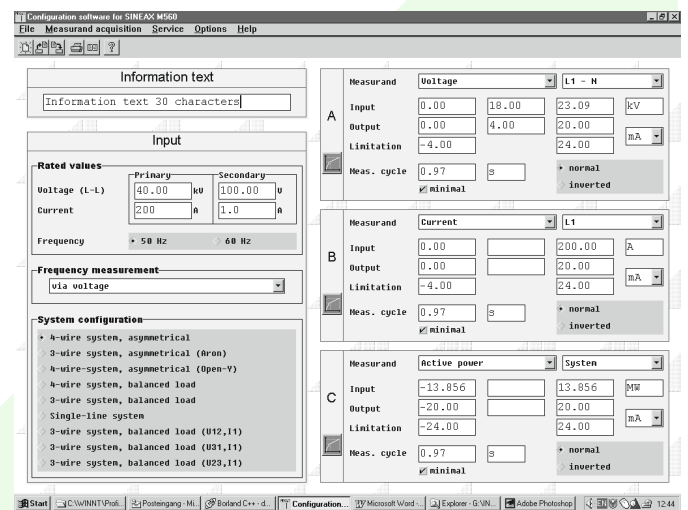
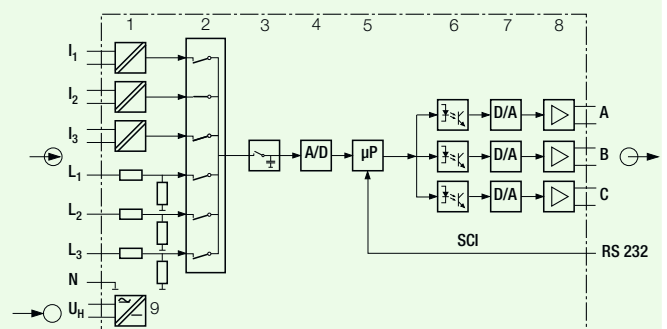

Fig. 2. Screen print-out from the configuration software (M563).



- 1 = Input transformer (I1, I2, I3)
- 1 = Voltage divider (L1, L2, L3)
- 2 = Multiplexer
- 3 = Latching stage
- 4 = A/D converter
- 5 = Microcontroller
- 6 = Electrical insulation
- 7 = D/A converter
- 8 = Output stage
- 9 = DC, AC power pack

Fig. 3. Block diagram (M563).

SINEAX M561 / M562 / M563 with 1, 2 resp. 3 analog outputs

Programmable Multi-Transducer for Industry

Symbols

Symbols	Meaning
X	Measured variable
X0	Lower limit of the measured variable
X1	Break point of the measured variable
X2	Upper limit of the measured variable
Y	Output variable
Y0	Lower limit of the output variable
Y1	Break point of the output variable
Y2	Upper limit of the output variable
Y2 SW	Programmed upper limit of the output variable
U	Input voltage
Ur	Rated value of the input voltage
U 12	Phase-to-phase voltage L1 – L2
U 23	Phase-to-phase voltage L2 – L3
U 31	Phase-to-phase voltage L3 – L1
U1N	Phase-to-neutral voltage L1 – N
U2N	Phase-to-neutral voltage L2 – N
U3N	Phase-to-neutral voltage L3 – N
I	Input current
I1	AC current L1
I2	AC current L2
I3	AC current L3
Ir	Rated value of the input current
IM	Average value of the currents $(I1 + I2 + I3) / 3$
IMS	Average value of the currents and sign of the active power (P)
IB	RMS value of the current with wire setting range (bimetal measuring function)
IBT	Response time for IB
BS	Slave pointer function for the measurement of the RMS value IB
BST	Response time for BS
φ	Phase-shift between current and voltage
F	Frequency of the input variable
Fn	Rated frequency
P	Active power of the system $P = P1 + P2 + P3$
P1	Active power phase 1 (phase-to-neutral L1 – N)

Symbols	Meaning
P2	Active power phase 2 (phase-to-neutral L2 – N)
P3	Active power phase 3 (phase-to-neutral L3 – N)
Q	Reactive power of the system $Q = Q1 + Q2 + Q3$
Q1	Reactive power phase 1 (phase-to-neutral L1 – N)
Q2	Reactive power phase 2 (phase-to-neutral L2 – N)
Q3	Reactive power phase 3 (phase-to-neutral L3 – N)
S	Apparent power of the system
S1	Apparent power phase 1 (phase-to-neutral L1 – N)
S2	Apparent power phase 2 (phase-to-neutral L2 – N)
S3	Apparent power phase 3 (phase-to-neutral L3 – N)
Sr	Rated value of the apparent power of the system
PF	Active power factor $\cos\varphi = P/S$
PF1	Active power factor phase 1 $P1/S1$
PF2	Active power factor phase 2 $P2/S2$
PF3	Active power factor phase 3 $P3/S3$
QF	Reactive power factor $\sin\varphi = Q/S$
QF1	Reactive power factor phase 1 $Q1/S1$
QF2	Reactive power factor phase 2 $Q2/S2$
QF3	Reactive power factor phase 3 $Q3/S3$
LF	Power factor of the system $LF = \text{sgn}Q \cdot (1 - PF)$
LF1	Power factor phase 1 $\text{sgn}Q1 \cdot (1 - PF1)$
LF2	Power factor phase 2 $\text{sgn}Q2 \cdot (1 - PF2)$
LF3	Power factor phase 3 $\text{sgn}Q3 \cdot (1 - PF3)$
c	Factor for the intrinsic error
R	Output load
Rn	Rated burden
H	Power supply
Hn	Rated value of the power supply
CT	c.t. ratio
VT	v.t. ratio

SINEAX M561 / M562 / M563 with 1, 2 resp. 3 analog outputs

Programmable Multi-Transducer for Industry

Applicable standards and regulations

IEC 688 or EN 60 688	Electrical measuring transducers for converting AC electrical variables into analog and digital signals
IEC 1010 or EN 61 010	Safety regulations for electrical measuring, control and laboratory equipment
iEC 529 or EN 60 529	Protection types by case (code IP)
IEC 1000-4-2/-3/-4/-5/-6	Electromagnetic compatibility for industrial-process measurement and control equipment
EN 55 011	Electromagnetic compatibility of data processing and telecommunication equipment Limits and measuring principles for radio interference and information equipment
IEC 68-2-1/-2/-3/-6/-27 or EN 60 068-2-1/-2/-3/-6/-27	Ambient tests -1 Cold, -2 Dry heat, -3 Damp heat, -6 Vibration, -27 Shock
DIN 40 110	AC quantities
DIN 43 807	Terminal markings
UL 94	Tests for flammability of plastic materials for parts in devices and appliances

Technical data

Measuring input

Nominal input voltage:	57.7 to 400 V (phase-to-neutral) resp. 100 to 693 V (phase-to-phase)
Nominal input current:	1 to 6 A
Admissible measuring range end values:	See page 4 under "System response", column "Condition", and pages 9 and 10 under "Description 13 and 14"
Waveform:	Sinusoidal
Rated frequency:	50 or 60 Hz
Consumption [VA]:	Voltage circuit: $U^2 / 400 \text{ k}\Omega$ with external power supply Current circuit: $\leq I^2 \cdot 0.01 \Omega$

Thermal rating of inputs

Input variable	Number of inputs	Duration of overload	Interval between two overloads
Current circuit			
400 V single-phase AC system 693 V three-phase system			
12 A	—	continuous	—
120 A	10	1 s	100 s
120 A	5	3 s	5 min.
250 A	1	1 s	1 hour
Voltage circuit			
480 V/831 V ¹	—	continuous	—
600 V/1040 V ¹	10	10 s	10 s
800 V/1386 V ¹	10	1 s	10 s

¹ Maximum 264 V across the power supply when it is obtained from the measured variable with a power supply unit for 85...230 V DC/AC and maximum 69 V with a power supply unit for 24...60 V DC/AC.

Analog outputs

For the outputs A, B and C:

Output variable Y	Impressed DC current	Impressed DC voltage
Full scale Y2	$1 \leq Y2 \leq 20 \text{ mA}$	$5 \leq Y2 \leq 10 \text{ V}$
Limits of output signal for input overload and/or	$R = 0$ $R \rightarrow \infty$	40 mA $1.2 \cdot Y2$
Rated useful range of output load	$0 \leq \frac{7.5 \text{ V}}{Y2} \leq \frac{15 \text{ V}}{Y2}$	$\frac{Y2}{2 \text{ mA}} \leq \frac{Y2}{1 \text{ mA}} \leq \infty$
AC component of output signal (peak-to-peak)	$\leq 0.01 \cdot Y2$	$\leq 0.01 \cdot Y2$

The outputs A, B and C may be either short or open-circuited. They are electrically insulated from each other and from all other circuits (floating).

All the full-scale output values can be reduced subsequently using the programming software, but a supplementary error results.

SINEAX M561 / M562 / M563 with 1, 2 resp. 3 analog outputs

Programmable Multi-Transducer for Industry

Reference conditions

Ambient temperature:	15 ... 30 °C
Pre-conditioning:	30 min. acc. to EN 60 688
Input variable:	Rated useful range
Power supply:	H = Hn ± 1%
Active/reactive factor:	cosφ = 1 resp. sinφ = 1
Frequency:	50 or 60 Hz
Waveform:	Sinusoidal, form factor 1.1107
Output load:	DC current output: $R_n = \frac{7.5 \text{ V}}{Y_2} \pm 1\%$ DC voltage output: $R_n = \frac{Y_2}{1 \text{ mA}} \pm 1\%$
Miscellaneous:	EN 60 688

System response

Accuracy class: (the reference value is the full-scale value Y2)

Measured variable X	Condition	Accuracy class ¹⁾
System: Active, reactive and apparent power	$0.5 \leq X_2/S_r \leq 1.5$ $0.3 \leq X_2/S_r < 0.5$	0.5 c 1.0 c
Phase: Active, reactive and apparent power	$0.167 \leq X_2/S_r \leq 0.5$ $0.1 \leq X_2/S_r < 0.167$	0.5 c 1.0 c
Power factor, active power and reactive power	$0.5S_r \leq S \leq 1.5 S_r$, $(X_2 - X_0) = 2$	0.5 c
	$0.5S_r \leq S \leq 1.5 S_r$, $1 \leq (X_2 - X_0) < 2$	1.0 c
	$0.5S_r \leq S \leq 1.5 S_r$, $0.5 \leq (X_2 - X_0) < 1$	2.0 c
	$0.1S_r \leq S < 0.5S_r$, $(X_2 - X_0) = 2$	1.0 c
	$0.1S_r \leq S < 0.5S_r$, $1 \leq (X_2 - X_0) < 2$	2.0 c
	$0.1S_r \leq S < 0.5S_r$, $0.5 \leq (X_2 - X_0) < 1$	4.0 c
AC voltage	$0.1 U_r \leq U \leq 1.2 U_r$	0.2 c
AC current/ current averages	$0.1 I_r \leq I \leq 1.2 I_r$	0.2 c
System frequency	$0.1 U_r \leq U \leq 1.2 U_r$ resp. $0.1 I_r \leq I \leq 1.2 I_r$	$0.15 + 0.03 c$

¹⁾ Basic accuracy 1,0 c for applications with phase-shift

Duration of the measurement cycle: Approx. 0.6 to 1.6 s at 50 Hz, depending on measured variable and programming

Response time: 1 ... 2 times the measurement cycle

Factor c (the highest value applies):

Linear characteristic:	$c = \frac{1 - \frac{Y_0}{Y_2}}{1 - \frac{X_0}{X_2}}$ or $c = 1$
Bent characteristic: $X_0 \leq X \leq X_1$	$c = \frac{Y_1 - Y_0}{X_1 - X_0} \cdot \frac{X_2}{Y_2}$ or $c = 1$
$X_1 < X \leq X_2$	$c = \frac{1 - \frac{Y_1}{Y_2}}{1 - \frac{X_1}{X_2}}$ or $c = 1$

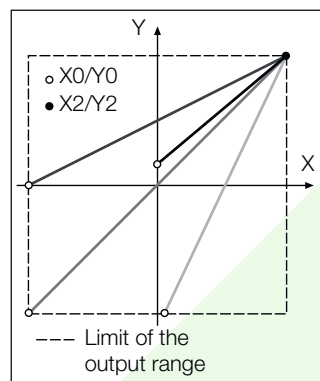

Fig. 4. Examples of settings with linear characteristic.

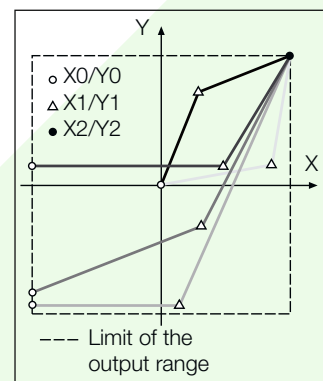

Fig. 5. Examples of settings with bent characteristic.

(System response inversely configurable)

Influencing quantities and permissible variations

Acc. to EN 60 688

Safety

Protection class:	II (protection isolated, EN 61 010-1)
Enclosure protection:	IP 40, housing (test wire, EN 60 529) IP 20, terminals (test finger, EN 60 529)
Pollution degree:	2
Installation category:	III (with ≤ 300 V versus earth) II (with > 300 V versus earth)
Insulation test (versus earth):	Inputs: 300 V ²⁾ 600 V ³⁾ Power supply: 230 V Outputs: 40 V

²⁾ Overvoltage category III

³⁾ Overvoltage category II

SINEAX M561 / M562 / M563 with 1, 2 resp. 3 analog outputs

Programmable Multi-Transducer for Industry

Surge test: 5 kV; 1.2/50 μ s; 0.5 Ws

Test voltage: 50 Hz, 1 min. acc. to EN 61 010-1
3700 V, inputs versus all other circuits as well as outer surface
2200 V, input circuits versus each other
3700 V, power supply versus outputs and outer surface
490 V, outputs versus each other and versus outer surface

Orientation: Any

Weight: Approx. 0.35 kg

Terminals

Type: Screw terminals with wire guards

Max. wire gauge: ≤ 4.0 mm² single wire or 2 \times 2.5 mm² fine wire

Ambient tests

EN 60 068-2-6: Vibration

Acceleration: ± 2 g

Frequency range: 10 ... 150 ... 10 Hz, rate of frequency sweep: 1 octave/minute

Number of cycles: 10, in each of the three axes

EN 60 068-2-27: Shock

Acceleration: 3 \times 50 g
3 shocks each in 6 directions

EN 60 068-2-1/-2/-3: Cold, dry heat, damp heat

Power supply \rightarrow

DC, AC power pack (DC or 50 ... 60 Hz)

Table 1: Rated voltages and tolerances

Rated voltage U_N	Tolerance
24 ... 60 V DC/AC	DC - 15 ... + 33%
85 ... 230 V DC/AC	AC \pm 15%

Consumption: ≤ 5 W resp. ≤ 7 VA

Programming connector on transducer

The programming connector on the transducer is connected by the programming cable PRKAB 560 to the RS-232 interface on the PC. The electrical insulation between the two is provided by the programming cable.

Installation data

Housing: Housing **P20/105**
See Section "Dimensioned drawings"

Housing material: Lexan 940 (polycarbonate), flammability class V-0 acc. to UL 94, self-extinguishing, non-dripping, free of halogen

Mounting: For snapping onto top-hat rail (35 \times 15 mm or 35 \times 7.5 mm) acc. to EN 50 022

Ambient conditions

Variations due to ambient temperature: $\pm 0.2\%$ / 10 K

Nominal range of use for temperature: 0 ... 15 ... 30 ... 45 $^{\circ}$ C (usage group II)

Operating temperature: - 10 to + 55 $^{\circ}$ C

Storage temperature: - 40 to + 85 $^{\circ}$ C

Annual mean relative humidity: $\leq 75\%$

Altitude: 2000 m max.

Indoor use statement

Dimensioned drawings

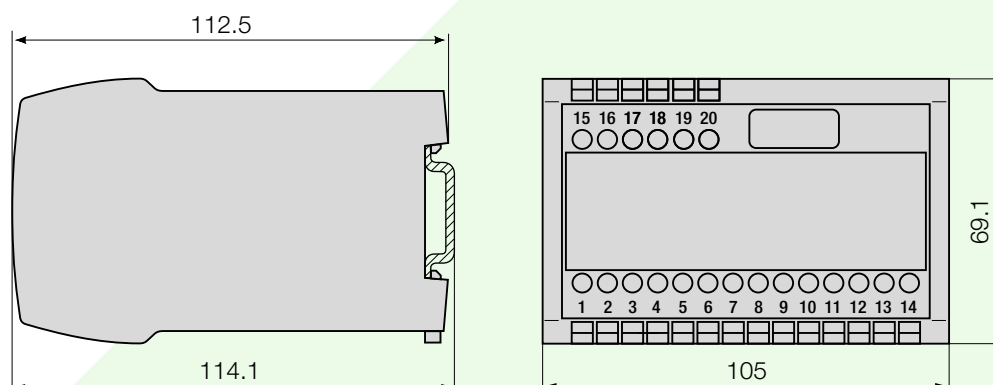

Fig. 6. SINEAX M 563 in housing **P20/105** clipped onto a top-hat rail (35 \times 15 mm or 35 \times 7.5 mm, acc. to EN 50 022).

SINEAX M561 / M562 / M563 with 1, 2 resp. 3 analog outputs

Programmable Multi-Transducer for Industry

**Table 2: SINEAX M 561 (1 analogue output)
SINEAX M 562 (2 analogue outputs)
SINEAX M 563 (3 analogue outputs) available as standard versions**

The versions of the transducer below programmed with the **basic** configuration are available ex stock. It is only necessary to quote the **Order No.:**

Description / Basic programming		Marking	Order No.		
			M 561	M 562	M 563
1. Mechanical design:	Housing P20/105 for rail mounting	561 - 4			
	Housing P20/105 for rail mounting	562 - 4			
	Housing P20/105 for rail mounting	563 - 4			
2. Rated input frequency:	50 Hz	1			
3. Power supply / external connection (standard):	24... 60 V DC/AC	1	158 411	158 437	146 458
	85...230 V DC/AC	2	158 429	158 445	146 440
4. Full-scale output signal, output A:	Y2 = 20 mA	1			
5. Full-scale output signal, output B:	Y2 = 20 mA	1			
6. Full-scale output signal, output C:	Y2 = 20 mA	1			
7. Test certificate:	None supplied	0			
8. Configuration:	Basic configuration	0			
See Table 3 "Ordering Information"					
Basic configuration					
Input data					
9. Application:	4-wire, 3-phase system asymmetric load (NPS)	H			
10. Nominal input voltage:	Rated value $U_r = 100\text{ V}$	A			
11. Nominal input current:	Rated value $I_r = 2\text{ A}$	9			
12. Primary rating:	Without specification of primary rating	0			
Output A					
13. Meas. variable/meas. range (part 1):	P1; $X_0 = 115.47\text{ W}$; $X_2 = 115.47\text{ W}$	2			
14. Meas. variable/meas. range (part 2):	Not used	0			
15. Signal range/system response:	$Y_0 = -20\text{ mA}$; $Y_2 = 20\text{ mA}$	1			
16. Characteristic:	Linear	1			
17. Limits:	Standard	1			
Output B					
18. Meas. variable/meas. range (part 1):	P2; $X_0 = 115.47\text{ W}$; $X_2 = 115.47\text{ W}$	2			
19. Meas. variable/meas. range (part 2):	Not used	0			
20. Signal range/system response:	$Y_0 = -20\text{ mA}$; $Y_2 = 20\text{ mA}$	1			
21. Characteristic:	Linear	1			
22. Limits:	Standard	1			
Output C					
23. Meas. variable/meas. range (part 1):	P3; $X_0 = 115.47\text{ W}$; $X_2 = 115.47\text{ W}$	2			
24. Meas. variable/meas. range (part 2):	Not used	0			
25. Signal range/system response:	$Y_0 = -20\text{ mA}$; $Y_2 = 20\text{ mA}$	1			
26. Characteristic:	Linear	1			
27. Limits:	Standard	1			

The complete Order Code according to "Table 3: Ordering information" should be stated for other versions..

SINEAX M561 / M562 / M563 with 1, 2 resp. 3 analog outputs

Programmable Multi-Transducer for Industry

Table 3: Ordering information

DESCRIPTION	MARKING
1. Mechanical design	
Housing P20/105 for rail mounting	561 - 4
Housing P20/105 for rail mounting	562 - 4
Housing P20/105 for rail mounting	563 - 4
2. Nominal input frequency	
50 Hz	1
60 Hz	2
3. Power supply / Connection	
24 ... 60 V DC/AC, external connection (standard)	1
85 ... 230 V DC/AC, external connection (standard)	2
24 ... 60 V AC, internal connection from measuring input	3
85 ... 230 V AC, internal connection from measuring input	4
Lines 3 and 4: Not allowed with application E, F and J in feature 9	
Line 3: Not allowed with nominal input voltage > 60 V _{L-L} (lines A and Z in feature 10)	
Line 4: Not allowed with nominal input voltage 57.74 V L-N (line 1 in feature 10)	
Please refer to remark under feature 10	
4. Output signal final value, output A	
Output A, Y2 = 20 mA (standard)	1
Output A, Y2 [mA]	(1 ≤ Y2 < 20 mA) 9
Output A, Y2 [V]	(5 ≤ Y2 ≤ 10 V) Z
5. Output signal final value, output B	
Output B not used (at M561)	0
Output B, Y2 = 20 mA (standard)	1
Output B, Y2 [mA]	(1 ≤ Y2 < 20 mA) 9
Output B, Y2 [V]	(5 ≤ Y2 ≤ 10 V) Z
6. Output signal final value, output C	
Output C not used (at M561 and M562)	0
Output C, Y2 = 20 mA (standard)	1
Output C, Y2 [mA]	(1 ≤ Y2 < 20 mA) 9
Output C, Y2 [V]	(5 ≤ Y2 ≤ 10 V) Z
7. Test records	
Without test records	0
With test records in German	D
With test records in English	E
8. Configuration	
Basic configuration programmed (see table 2)	0
Programmed to order	9
Line 0: No further details are necessary when specifying the basic configuration. Not allowed with internal power supply from measuring input.	
Line 9: The order must include a full specification of the following features 9 to 27 by means of a completely filled in form W 2407e (see appendix) with the configuration information.	

Table 3 continued on next page!

SINEAX M561 / M562 / M563 with 1, 2 resp. 3 analog outputs

Programmable Multi-Transducer for Industry

Continuation "Table 3: Ordering Information"

DESCRIPTION	MARKING
9. Application (system)	
Single-phase AC	A
4-wire, 3-phase symmetric load	B
3-wire, 3-phase symmetric load	C
3-wire, 3-phase symmetric load, phase-shift U_{L1-L2} / I_{L1}^*	D
3-wire, 3-phase symmetric load, phase-shift U_{L3-L1} / I_{L1}^*	E
3-wire, 3-phase symmetric load, phase-shift U_{L2-L3} / I_{L1}^*	F
3-wire, 3-phase asymmetric load	G
4-wire, 3-phase asymmetric load	H
4-wire, 3-phase asymmetric load, open-Y	J
Lines E, F, J: Not possible with power supply from measuring input!	
10. Nominal input voltage	
Rated value $U_r = 57.74 \text{ V}$ phase-to-neutral	1
Rated value $U_r [V_{L-N}]$: <input type="text"/> $(57.74 V_{L-N} < U_r \leq 400 V_{L-N})^1$	9
Rated value $U_r = 100 \text{ V}$ phase-to-phase	A
Rated value $U_r [V_{L-L}]$: <input type="text"/> $(100 V_{L-L} < U_r \leq 693 V_{L-L})^1$	Z
¹ Max. 230 V with power supply from measuring input (feature 3, line 4)! The transducer is only valid for the rated power supply range when the power supply is being taken from the measuring input (symmetrically loaded single-phase and four-wire three-phase supply: $L1-N$; otherwise $L1-L2$). Lines 1 and 9: Only for application A and B Lines A and Z: Only for application C to J	
11. Nominal input current	
Rated value $I_r = 1 \text{ A}$	1
Rated value $I_r = 5 \text{ A}$	2
Rated value $I_r [A]$ <input type="text"/> $(1 \text{ A} < I_r \leq 6 \text{ A})$	9
12. Primary rating (voltage and current transformer)	
Without specification of primary rating	0
VT, U prim = <input type="text"/> kV	9
CT, I prim = <input type="text"/> A	
Line 9: Specify transformer ratio primary, e.g. 33 kV, 1000 A The secondary ratings must correspond to the rated input voltage and current specified for feature 10, respectively 11.	

* Basic accuracy 1.0 c

Table 3 continued on next page!

SINEAX M561 / M562 / M563 with 1, 2 resp. 3 analog outputs

Programmable Multi-Transducer for Industry

Continuation "Table 3: Ordering information"

DESCRIPTION						Application			Marking
						A...F	G	H/J	
13. Output A, measured variable, range									
Part 1 (power, power factor, frequency)									
Part 1 not used									0
P	System	X0:		X2:		●	●	●	1
P1	L1	X0:		X2:				●	2
P2	L2	X0:		X2:				●	3
P3	L3	X0:		X2:				●	4
Q	System	X0:		X2:		●	●	●	5
Q1	L1	X0:		X2:				●	6
Q2	L2	X0:		X2:				●	7
Q3	L3	X0:		X2:				●	8
S	System	X0:		X2:		●	●	●	A
S1	L1	X0:		X2:				●	B
S2	L2	X0:		X2:				●	C
S3	L3	X0:		X2:				●	D
PF	System	X0:		X2:		●	●	●	E
PF1	L1	X0:		X2:				●	F
PF2	L2	X0:		X2:				●	G
PF3	L3	X0:		X2:				●	H
QF	System	X0:		X2:		●	●	●	J
QF1	L1	X0:		X2:				●	K
QF2	L2	X0:		X2:				●	L
QF3	L3	X0:		X2:				●	M
LF	System	X0:		X2:		●	●	●	N
LF1	L1	X0:		X2:				●	P
LF2	L2	X0:		X2:				●	Q
LF3	L3	X0:		X2:				●	R
F	Frequency	X0:		X2:		●	●	●	S
Meas. variable:		Initial range X0		Final range X2					
P, Q	System	$-X2 \leq X0 \leq 0.8 X2$		$0.3 \leq X2/Sr \leq 1.5$					
P, Q	L1/L2/L3	$-X2 \leq X0 \leq 0.8 X2$		$0.1 \leq X2/Sr \leq 0.5$					
S	System	$0 \leq X0 \leq 0.8 X2$		$0.3 \leq X2/Sr \leq 1.5$					
S	L1/L2/L3	$0 \leq X0 \leq 0.8 X2$		$0.1 \leq X2/Sr \leq 0.5$					
PF, QF, LF		$-1 \leq X0 \leq (X2 - 0.5)$		$0 \leq X2 \leq 1$					
F		$45 \text{ Hz} \leq X0 \leq (X2 - 1) \text{ Hz}$		$(X0 + 1) \text{ Hz} \leq X2 \leq 65 \text{ Hz}$					

Table 3 continued on next page!

SINEAX M561 / M562 / M563 with 1, 2 resp. 3 analog outputs

Programmable Multi-Transducer for Industry

Continuation "Table 3: Ordering information"

DESCRIPTION	Application			Marking
	A...F	G	H/J	
14. Output A, measured variable, range				
Part 2 (current, voltage)				
Part 2 not used				0
I System X0: X2:	●			1
I1 L1 X0: X2:		●	●	2
I2 L2 X0: X2:		●	●	3
I3 L3 X0: X2:		●	●	4
IB System (15 min) X0: X2:	●			5
IB1 L1 (15 min) X0: X2:		●	●	6
IB2 L2 (15 min) X0: X2:		●	●	7
IB3 L3 (15 min) X0: X2:		●	●	8
BS System (15 min) X0: X2:	●			A
BS1 L1 (15 min) X0: X2:		●	●	B
BS2 L2 (15 min) X0: X2:		●	●	C
BS3 L3 (15 min) X0: X2:		●	●	D
IM System X0: X2:		●	●	E
IMS System X0: X2:		●	●	F
U System X0: X2:	●			G
U1N L1-N X0: X2:			●	H
U2N L2-N X0: X2:			●	J
U3N L3-N X0: X2:			●	K
U12 L1-L2 X0: X2:		●	●	L
U23 L2-L3 X0: X2:		●	●	M
U31 L3-L1 X0: X2:		●	●	N
Meas. variable: Initial range X0 Final range X2				
I, I1, I2, I3 0 ≤ X0 ≤ 0.8 X2 0.5 Ir ≤ X2 ≤ 1.2 Ir				
IB, IBS X0 = 0 0.5 Ir ≤ X2 ≤ 1.2 Ir				
IM 0 ≤ X0 ≤ 0.8 X2 0.5 Ir ≤ X2 ≤ 1.2 Ir				
IMS -X2 ≤ X0 ≤ 0.8 X2 0.5 Ir ≤ X2 ≤ 1.2 Ir				
U System 0 ≤ X0 ≤ 0.9 X2 0.8 Ur ≤ X2 ≤ 1.2 Ur				
U L1-L2 0 ≤ X0 ≤ 0.9 X2 0.8 Ur ≤ X2 ≤ 1.2 Ur				
U L2-L3 0 ≤ X0 ≤ 0.9 X2 0.8 Ur ≤ X2 ≤ 1.2 Ur				
U L3-L1 0 ≤ X0 ≤ 0.9 X2 0.8 Ur ≤ X2 ≤ 1.2 Ur				
U L1-N 0 ≤ X0 ≤ 0.9 X2 0.8 Ur/√3 ≤ X2 ≤ 1.2 Ur/√3				
U L2-N 0 ≤ X0 ≤ 0.9 X2 0.8 Ur/√3 ≤ X2 ≤ 1.2 Ur/√3				
U L3-N 0 ≤ X0 ≤ 0.9 X2 0.8 Ur/√3 ≤ X2 ≤ 1.2 Ur/√3				
15. Output A, signal range, system response				
Not used				0
Signal (Y0 ... Y2SW): -Y2 ... Y2				1
Signal (Y0 ... Y2SW): 0 ... Y2				2
Signal (Y0 ... Y2SW): 0.2 Y2... Y2				3
Signal Y0 ... Y2SW:				9
Signal inversely (Y2SW ... Y0): Y2 ... -Y2				A
Signal inversely (Y2SW ... Y0): Y2 ... 0				B
Signal inversely (Y2SW ... Y0): Y2 ... 0.2 Y2				C
Signal inversely Y2SW ... Y0:				Z
Lines 9 and Z: Y2 = selected final value in feature 4. Specify Y0 and Y2SW in mA or V, within the limits 1 ≤ Y2SW ≤ Y2 (additional error!); -Y2SW ≤ Y0 ≤ 0.2 Y2SW				

Table 3 continued on next page!

SINEAX M561 / M562 / M563 with 1, 2 resp. 3 analog outputs

Programmable Multi-Transducer for Industry

Continuation "Table 3: Ordering information"

DESCRIPTION	Marking
16. Output A, characteristic	
Not used	0
Characteristic linear	1
Characteristic kinked X1: <input type="text"/> Y1: <input type="text"/>	9
Line 9: Specify kink point, X1 (input) as value of the measured quantity, Y1 (output) in mA or V, within the limits $(X0 + 0.015 X2) \leq X1 \leq 0.985 X2$; $Y0 \leq Y1 \leq Y2SW$	
17. Output A, limitation	
Not used	0
Limitation Standard ($Y_{min} = Y0 - 0.2 Y2SW$; $Y_{max} = 1.2 Y2SW$)	1
Limitation Ymin: <input type="text"/> Ymax.: <input type="text"/>	9
$(Y0 - 0.2 Y2SW) \leq Y_{min} \leq Y0$; $Y2SW \leq Y_{max} \leq 1.2 Y2SW$	
In case of SINEAX M561 the coding is completed up to here!	
18. Output B, measured variable, range	Application
Part 1 (power, power factor, frequency)	A...F G H/J
Part 1 not used	
P Netz X0: <input type="text"/> X2: <input type="text"/>	● ● ●
P1 L1 X0: <input type="text"/> X2: <input type="text"/>	●
etc. see output A, feature 13	●
19. Output B, measured variable, range	
Part 2 (current, voltage)	
Part 2 not used	0
I System X0: <input type="text"/> X2: <input type="text"/>	●
I1 L1 X0: <input type="text"/> X2: <input type="text"/>	● ●
etc. see output A, feature 14	● ●
20. Output B, signal range, system response	
Not used	0
Signal ($Y0 \dots Y2SW$): $-Y2 \dots Y2$	1
Signal ($Y0 \dots Y2SW$): $0 \dots Y2$	2
Signal ($Y0 \dots Y2SW$): $0.2 Y2 \dots Y2$	3
Signal $Y0 \dots Y2SW$: <input type="text"/>	9
Signal inversely ($Y2SW \dots Y0$): $Y2 \dots -Y2$	A
Signal inversely ($Y2SW \dots Y0$): $Y2 \dots 0$	B
Signal inversely ($Y2SW \dots Y0$): $Y2 \dots 0.2 Y2$	C
Signal inversely $Y2SW \dots Y0$: <input type="text"/>	Z
Lines 9 and Z: $Y2 =$ selected final value in feature 4. Specify $Y0$ and $Y2SW$ in mA or V, within the limits $1 \leq Y2SW \leq Y2$ (additional error!); $-Y2SW \leq Y0 \leq 0.2 Y2SW$	
21. Output B, characteristic	
Not used	0
Characteristic linear	1
Characteristic kinked X1: <input type="text"/> Y1: <input type="text"/>	9
Line 9: Specify kink point, X1 (input) as value of the measured quantity, Y1 (output) in mA or V, within the limits $(X0 + 0.015 X2) \leq X1 \leq 0.985 X2$; $Y0 \leq Y1 \leq Y2SW$	
22. Output B, limitation	
Not used	0
Limitation Standard ($Y_{min} = Y0 - 0.2 Y2SW$; $Y_{max} = 1.2 Y2SW$)	1
Limitation Ymin: <input type="text"/> Ymax.: <input type="text"/>	9
$(Y0 - 0.2 Y2SW) \leq Y_{min} \leq Y0$; $Y2SW \leq Y_{max} \leq 1.2 Y2SW$	
In case of SINEAX M562 the coding is completed up to here!	

Table 3 continued on next page!

SINEAX M561 / M562 / M563 with 1, 2 resp. 3 analog outputs

Programmable Multi-Transducer for Industry

Continuation "Table 3: Ordering Information"

DESCRIPTION							Marking	
23. Output C, measured variable, range Part 1 (power, power factor, frequency) Part 1 not used				Application			0	
				A...F	G	H/J		
P System	X0:		X2:		●	●	●	1
P1 L1	X0:		X2:				●	2
etc. see output A, feature 13						●		3
24. Output C, measured variable, range Part 2 (current, voltage) Part 2 not used							0	
I System	X0:		X2:		●			1
I1 L1	X0:		X2:			●	●	2
etc. see output A, feature 14					●	●		3
25. Output C, signal range, system response								
Not used							0	
Signal (Y0 ... Y2SW): - Y2 ... Y2							1	
Signal (Y0 ... Y2SW): 0 ... Y2							2	
Signal (Y0 ... Y2SW): 0.2 Y2 ... Y2							3	
Signal Y0 ... Y2SW:							9	
Signal inversely (Y2SW ... Y0): Y2 ... - Y2							A	
Signal inversely (Y2SW ... Y0): Y2 ... 0							B	
Signal inversely (Y2SW ... Y0): Y2 ... 0.2 Y2							C	
Signal inversely Y2SW ... Y0:							Z	
Lines 9 and Z: Y2 = selected final value in feature 4. Specify Y0 and Y2SW in mA or V, within the limits $1 \leq Y2SW \leq Y2$ (additional error!); $- Y2SW \leq Y0 \leq 0.2 Y2SW$								
26. Output C, characteristic								
Not used							0	
Characteristic linear							1	
Characteristic kinked							9	
Line 9: Specify kink point, X1 (input) as value of the measured quantity, Y1 (output) in mA or V, within the limits $(X0 + 0.015 X2) \leq X1 \leq 0.985 X2$; $Y0 \leq Y1 \leq Y2SW$								
27. Output C, limitation								
Not used							0	
Limitation Standard (Ymin = Y0 - 0.2 Y2SW; Ymax = 1.2 Y2SW)							1	
Limitation							9	
$(Y0 - 0.2 Y2SW) \leq Ymin \leq Y0$; $Y2SW \leq Ymax \leq 1.2 Y2SW$								

SINEAX M561 / M562 / M563 with 1, 2 resp. 3 analog outputs

Programmable Multi-Transducer for Industry

Electrical connections

Function	Connection		
Measuring input \rightarrow AC current	IL1	1 / 3	
	IL2	4 / 6	
	IL3	7 / 9	
AC voltage	UL1	2	
	UL2	5	
	UL3	8	
	N	11	
Outputs \rightarrow Analog	M561: Output A		
	M562: Output A + B		
	M563: Output A + B + C		
	\rightarrow A	-	15
		+	16
	\rightarrow B	-	17
		+	18
	\rightarrow C	-	19
		+	20
	Power supply \rightarrow	AC	~
~			14
DC		-	13
		+	14
RS 232 C interface			

If power supply is taken from the measured voltage internal connections are as follow:

Application (system)	Internal connection Terminal / System
Single-phase AC current	2 / 11 (L1 - N)
4-wire 3-phase symmetric load	2 / 11 (L1 - N)
All other (apart from feature 9, lines E and F)	2 / 5 (L1 - L2)

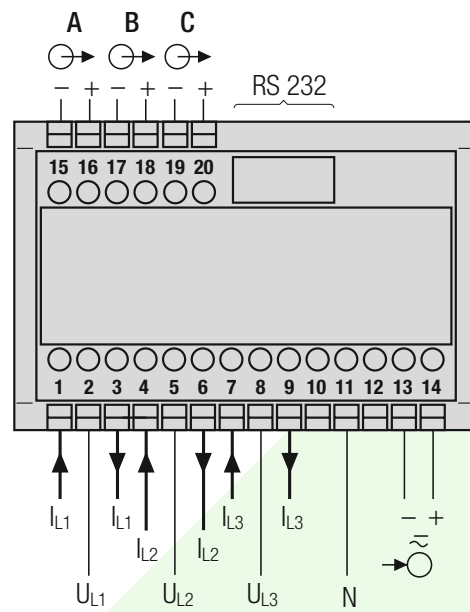

\rightarrow Measuring inputs, acc. to measuring mode

Measuring inputs

System / Application	Terminals		
Single-phase AC system			
4-wire 3-phase symmetric load I: L-1			
Connect the voltage according to the following table for current measurement in L2 or L3:			
Current transformer	Terminals	2	11
L2	1 3	L2	N
L3	1 3	L3	N

SINEAX M561 / M562 / M563 with 1, 2 resp. 3 analog outputs

Programmable Multi-Transducer for Industry

Measuring inputs

System /
Application

Terminals

3-wire
3-phase
symmetric
load

I: L1

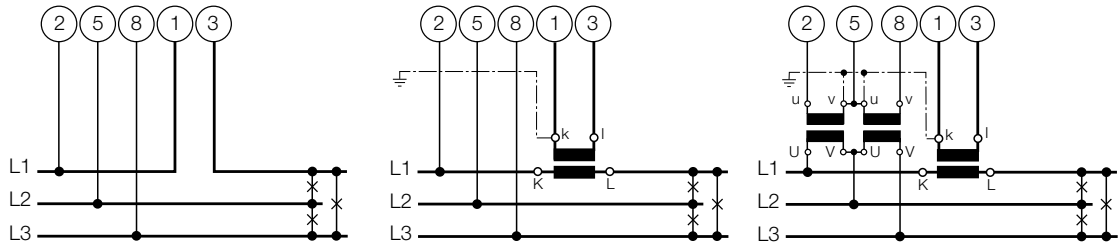

Connect the voltage according to the following table for current measurement in L2 or L3:

Current transformer	Terminals		2	5	8
L2	1	3	L2	L3	L1
L3	1	3	L3	L1	L2

3-wire
3-phase
symmetric
load

Phase-shift

U: L1 – L2

I: L1

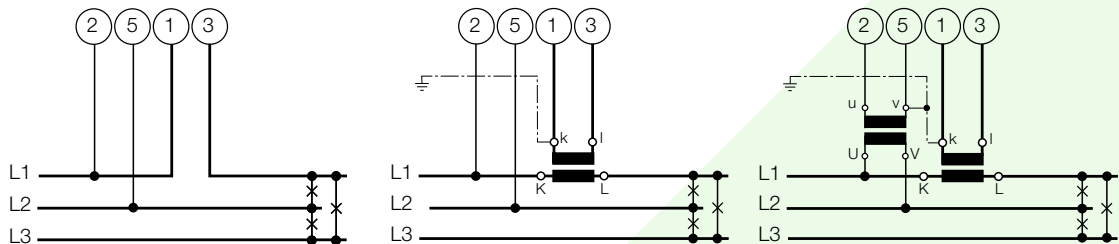

Connect the voltage according to the following table for current measurement in L2 or L3:

Current transformer	Terminals		2	5
L2	1	3	L2	L3
L3	1	3	L3	L1

3-wire
3-phase
symmetric
load

Phase-shift

U: L3 – L1

I: L1

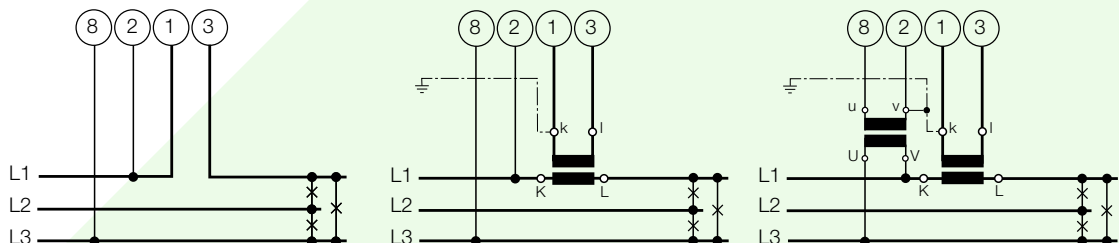

Connect the voltage according to the following table for current measurement in L2 or L3:

Current transformer	Terminals		8	2
L2	1	3	L1	L2
L3	1	3	L2	L3

SINEAX M561 / M562 / M563 with 1, 2 resp. 3 analog outputs

Programmable Multi-Transducer for Industry

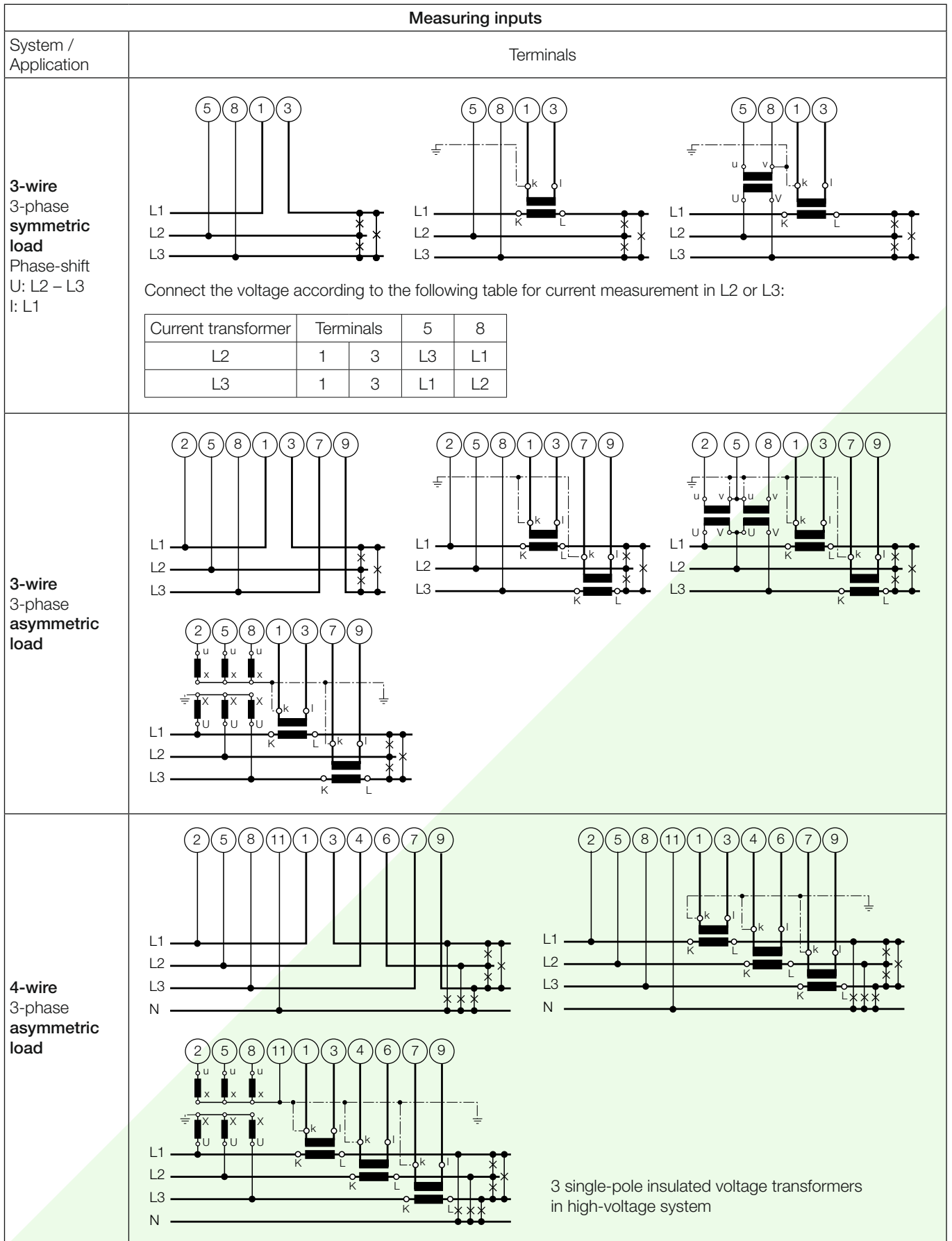

SINEAX M561 / M562 / M563 with 1, 2 resp. 3 analog outputs

Programmable Multi-Transducer for Industry

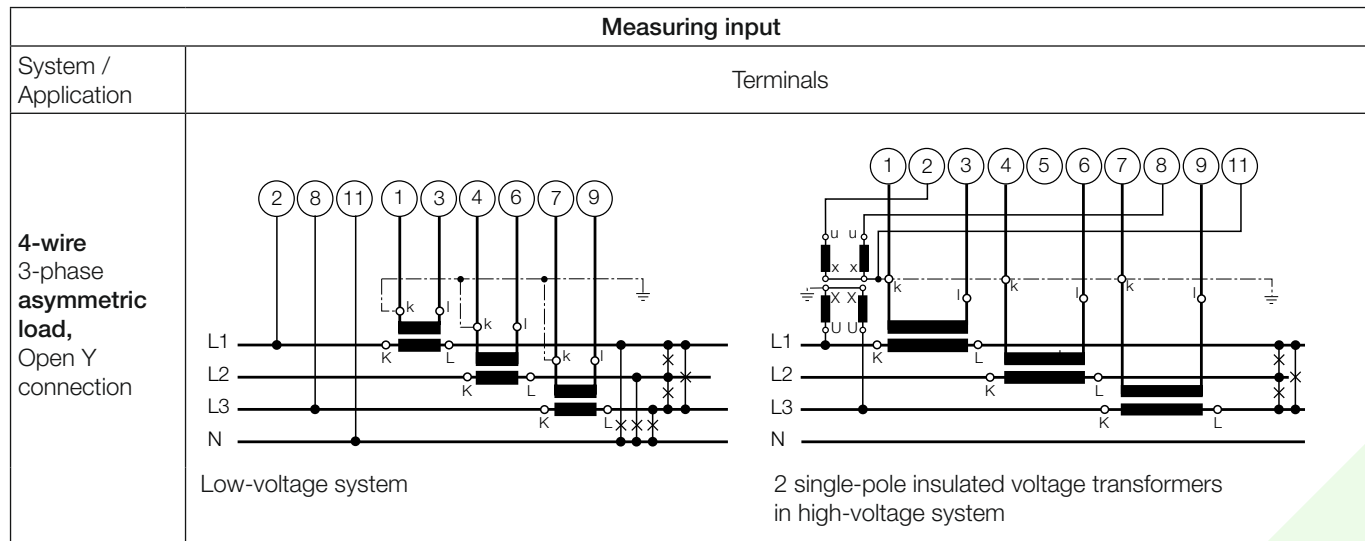

Relationship between PF, QF and LF

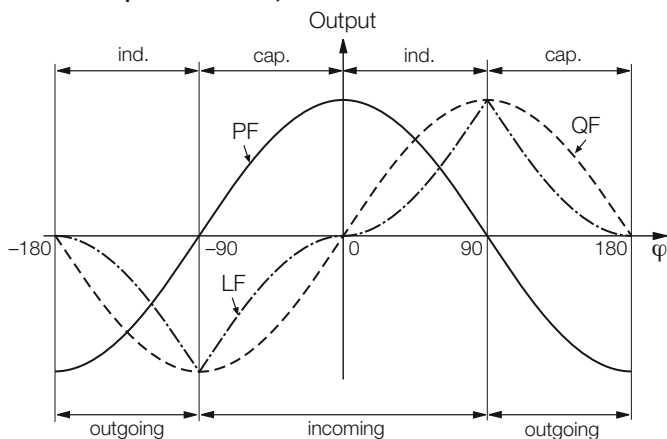

Fig. 7. Active power PF —, reactive power QF -----, power factor LF - - - - -.

Table 4: Accessories and spare parts

Description	Order No.
Programming cable PRKAB 560	147 779
Ancillary cable	143 587
Configuration software M 560 Windows 3.1 or higher on CD in German, English, French, Italian and Dutch	146 557
In addition, the CD contains all configuration programmes presently available for Camille Bauer products.	
Operating Instructions M 561/M 562-4 B d-f-e in three languages: German, French, English	156 316
Operating Instructions M 563-4 B d-f-e in three languages: German, French, English	143 579

Standard accessories

- 1 Operating Instructions for SINEAX M561/M562 resp. M563, in three languages: German, French, English
- 1 blank type label, for recording programmed settings

 **CAMILLE BAUER**
Rely on us.

Appendix: CONFIGURATION FOR SINEAX M561 / M562 / M563

with 1, 2 resp. 3 analogue outputs and RS 232 interface

(see data sheet M561/M562/M563 Le, Table 3: "Ordering information")

Customer / Agent: _____	Date: _____
Order No. / Item: _____	Delivery date: _____
No of instruments: _____	
Type of instrument (marking): _____	

<input type="checkbox"/>	9. Application		
	System _____		
<input type="checkbox"/>	10. Nominal input voltage, rated value		
	Ur = _____		
<input type="checkbox"/>	11. Nominal input current, rated value		
	Ir = _____		
<input type="checkbox"/>	12. Primary transformer		
	VT = _____ kV	CT = _____ A	
	Specify transformer ratio primary, e.g. 33 kV, 1000 A The secondary ratings must correspond to the rated input voltage and current specified for feature 10, respectively 11.		
Output A			
<input type="checkbox"/>	Part 1 (power, power factor, frequency)		
	13. Measured variable	Type: _____	X0 = _____ X2 = _____
<input type="checkbox"/>	Part 2 (current, voltage)		
	14. Measured variable	Type: _____	X0 = _____ X2 = _____
<input type="checkbox"/>	15. Output signal	Y0 = _____	Y2 = _____
<input type="checkbox"/>	16. Characteristic linear / bent	X1 = _____	Y1 = _____
<input type="checkbox"/>	17. Limits	Standard / Ymin = _____	Ymax = _____
Output B (not used with type M561)			
<input type="checkbox"/>	Part 1 (power, power factor, frequency)		
	18. Measured variable	Type: _____	X0 = _____ X2 = _____
<input type="checkbox"/>	Part 2 (current, voltage)		
	19. Measured variable	Type: _____	X0 = _____ X2 = _____
<input type="checkbox"/>	20. Output signal	Y0 = _____	Y2 = _____
<input type="checkbox"/>	21. Characteristic linear / bent	X1 = _____	Y1 = _____
<input type="checkbox"/>	22. Limite	Standard / Ymin = _____	Ymax = _____
Output C (not used with type type M561 and M562)			
<input type="checkbox"/>	Part 1 (power, power factor, frequency)		
	23. Measured variable	Type: _____	X0 = _____ X2 = _____
<input type="checkbox"/>	Part 2 (current, voltage)		
	24. Measured variable	Type: _____	X0 = _____ X2 = _____
<input type="checkbox"/>	25. Output signal	Y0 = _____	Y2 = _____
<input type="checkbox"/>	26. Characteristic linear / bent	X1 = _____	Y1 = _____
<input type="checkbox"/>	27. Limits	Standard / Ymin = _____	Ymax = _____

Order example see on next page1!

Order example type SINEAX M563:

Codes for features 1 to 8:

ITEM	Description	MARKING
1.	Mechanical design Housing P20/105 for rail mounting	563 – 4
2.	Nominal input frequency 50 Hz	1
3.	Power supply / Connection 85...230 V DC/AC	2
4.	Output signal final value, output A Y2 = 20 mA	1
5.	Output signal final value, output B Y2 = 20 mA	1
6.	Output signal final value, output C Y2 = 20 mA	1
7.	Without test records	0
8.	Configuration, programmed to order	9

Codes for features 9 to 27:

Features 9 to 27 concern data for configuring the software.

ITEM	Description	MARKING
9.	Application System 4-wire, 3-phase asymmetric load	H
10.	Nominal input voltage, rated value Ur = 400 V	Z
11.	Nominal input current, rated value Ir = 2 A	9
12.	Primary rating VT = 4 kV, CT = 200 A Specify transformer ratio primary, e.g. 4 kV, 200 A The secondary ratings must correspond to the rated input voltage and current specified for feature 10, respectively 11.	9
13.	Output A Part 1 (power, power factor, frequency) Measured value Type: P1 X0 = - 500 X2 = 500 kW	2
14.	Part 2 (current, voltage) Measured variable, meas. range Type: / X0 = / X2 = /	0
15.	Signal range, system response Y0 = - 20 Y2 = 20 mA	1
16.	Characteristic linear / kinked X1 = / Y1 = /	1
17.	Limitation Standard / Ymin = / Ymax = /	1
18.	Output B Part 1 (power, power factor, frequency) Measured variable Type: / X0 = / X2 = /	0
19.	Part 2 (current, voltage) Measured variable, meas. range Type: IB1 (15 min) X0 = 0 X2 = 200 A	6
20.	Signal range, system response Y0 = 0 Y2 = 20 mA	2
21.	Characteristic linear / kinked X1 = / Y1 = /	1
22.	Limitation Standard / Ymin = / Ymax = /	1
23.	Output C Part 1 (power, power factor, frequency) Measured variable Type: S1 X0 = 0 X2 = 600 kVA	B
24.	Part 2 (current, voltage) Measured variable, meas. range Type: / X0 = / X2 = /	0
25.	Signal range, system response Y0 = 0 Y2 = 20 mA	2
26.	Characteristic linear / kinked X1 = 400 kVA Y1 = 4 mA	9
27.	Limitation Standard / Ymin = / Ymax = /	1

По вопросам продажи и поддержки обращайтесь:

Архангельск (8182)63-90-72
Астана (7172)727-132
Астрахань (8512)99-46-04
Барнаул (3852)73-04-60
Белгород (4722)40-23-64
Брянск (4832)59-03-52
Владивосток (423)249-28-31
Волгоград (844)278-03-48
Вологда (8172)26-41-59
Воронеж (473)204-51-73
Екатеринбург (343)384-55-89
Иваново (4932)77-34-06
Ижевск (3412)26-03-58
Казань (843)206-01-48

Калининград (4012)72-03-81
Калуга (4842)92-23-67
Кемерово (3842)65-04-62
Киров (8332)68-02-04
Краснодар (861)203-40-90
Красноярск (391)204-63-61
Курск (4712)77-13-04
Липецк (4742)52-20-81
Магнитогорск (3519)55-03-13
Москва (495)268-04-70
Мурманск (8152)59-64-93
Набережные Челны (8552)20-53-41
Нижний Новгород (831)429-08-12
Новокузнецк (3843)20-46-81

Новосибирск (383)227-86-73
Омск (3812)21-46-40
Орел (4862)44-53-42
Оренбург (3532)37-68-04
Пенза (8412)22-31-16
Пермь (342)205-81-47
Ростов-на-Дону (863)308-18-15
Рязань (4912)46-61-64
Самара (846)206-03-16
Санкт-Петербург (812)309-46-40
Саратов (845)249-38-78
Севастополь (8692)22-31-93
Симферополь (3652)67-13-56
Смоленск (4812)29-41-54

Сочи (862)225-72-31
Ставрополь (8652)20-65-13
Сургут (3462)77-98-35
Тверь (4822)63-31-35
Томск (3822)98-41-53
Тула (4872)74-02-29
Тюмень (3452)66-21-18
Ульяновск (8422)24-23-59
Уфа (347)229-48-12
Хабаровск (4212)92-98-04
Челябинск (351)202-03-61
Череповец (8202)49-02-64
Ярославль (4852)69-52-93

Единый адрес для всех регионов: cmn@nt-rt.ru || www.camille-bauer.nt-rt.ru

PROCESS CONTROL ENGINEERING



ANGULAR POSITION ENGINEERING



HEAVY CURRENT ENGINEERING

