



Многофункциональный преобразователь SINEAX CAM

Архангельск (8182)63-90-72
Астана (7172)727-132
Астрахань (8512)99-46-04
Барнаул (3852)73-04-60
Белгород (4722)40-23-64
Брянск (4832)59-03-52
Владивосток (423)249-28-31
Волгоград (844)278-03-48
Вологда (8172)26-41-59
Воронеж (473)204-51-73
Екатеринбург (343)384-55-89
Иваново (4932)77-34-06
Ижевск (3412)26-03-58
Казань (843)206-01-48

Калининград (4012)72-03-81
Калуга (4842)92-23-67
Кемерово (3842)65-04-62
Киров (8332)68-02-04
Краснодар (861)203-40-90
Красноярск (391)204-63-61
Курск (4712)77-13-04
Липецк (4742)52-20-81
Магнитогорск (3519)55-03-13
Москва (495)268-04-70
Мурманск (8152)59-64-93
Набережные Челны (8552)20-53-41
Нижний Новгород (831)429-08-12
Новокузнецк (3843)20-46-81

Новосибирск (383)227-86-73
Омск (3812)21-46-40
Орел (4862)44-53-42
Оренбург (3532)37-68-04
Пенза (8412)22-31-16
Пермь (342)205-81-47
Ростов-на-Дону (863)308-18-15
Рязань (4912)46-61-64
Самара (846)206-03-16
Санкт-Петербург (812)309-46-40
Саратов (845)249-38-78
Севастополь (8692)22-31-93
Симферополь (3652)67-13-56
Смоленск (4812)29-41-54

Сочи (862)225-72-31
Ставрополь (8652)20-65-13
Сургут (3462)77-98-35
Тверь (4822)63-31-35
Томск (3822)98-41-53
Тула (4872)74-02-29
Тюмень (3452)66-21-18
Ульяновск (8422)24-23-59
Уфа (347)229-48-12
Хабаровск (4212)92-98-04
Челябинск (351)202-03-61
Череповец (8202)49-02-64
Ярославль (4852)69-52-93

Единый адрес для всех регионов: cmn@nt-rt.ru || www.camille-bauer.nt-rt.ru

использовано с разрешения официального
дистрибьютора АО «ЮЕ-Интернейшнл»

SINEAX CAM

Universal measuring unit for heavy current variables

Main features

- Consistent measurement (without interruption)
- Suitable for strongly distorted networks, zero crossing or phase angle controls
- I/O interface adaptable to individual requirements
- Configuration and measured value acquisition via USB and Modbus interface
- Acquisition of minimum and maximum values with time stamp
- Graphic display with free measurement display assembling and alarm handling
- Logger for long-term recording of measurement progressions
- Lists for recording events, alarms and system messages

Application

SINEAX CAM is designed for measurements in electric distribution systems or in industrial facilities. Along with the current system state the pollution due to non-linear loads as well as the overall load of the supply system can be detected. Consistent measurement also guarantees that every network change is reliably acquired and included in measured data. The



Fig. 1. SINEAX CAM in top-hat rail housing.

high-performance measuring system makes the device also suitable for strong distorted systems as well as for zero crossing or phase-angle controls.

The I/O interface may be individually assorted depending on the application. Up to 4 modules with different functionality may be used.

The logger allows long-term recordings of measurement progressions, e.g. to monitor the variable load of transformers, as well as meter readings at definable times. Lists offer

the chronological recording of events, alarms or system messages for further analysis of occurrences in the power system.

The graphic display is intended for on-site visualization of measurements, lists and alarms. Via keypad the user can e.g. acknowledge alarms or reset extreme values.

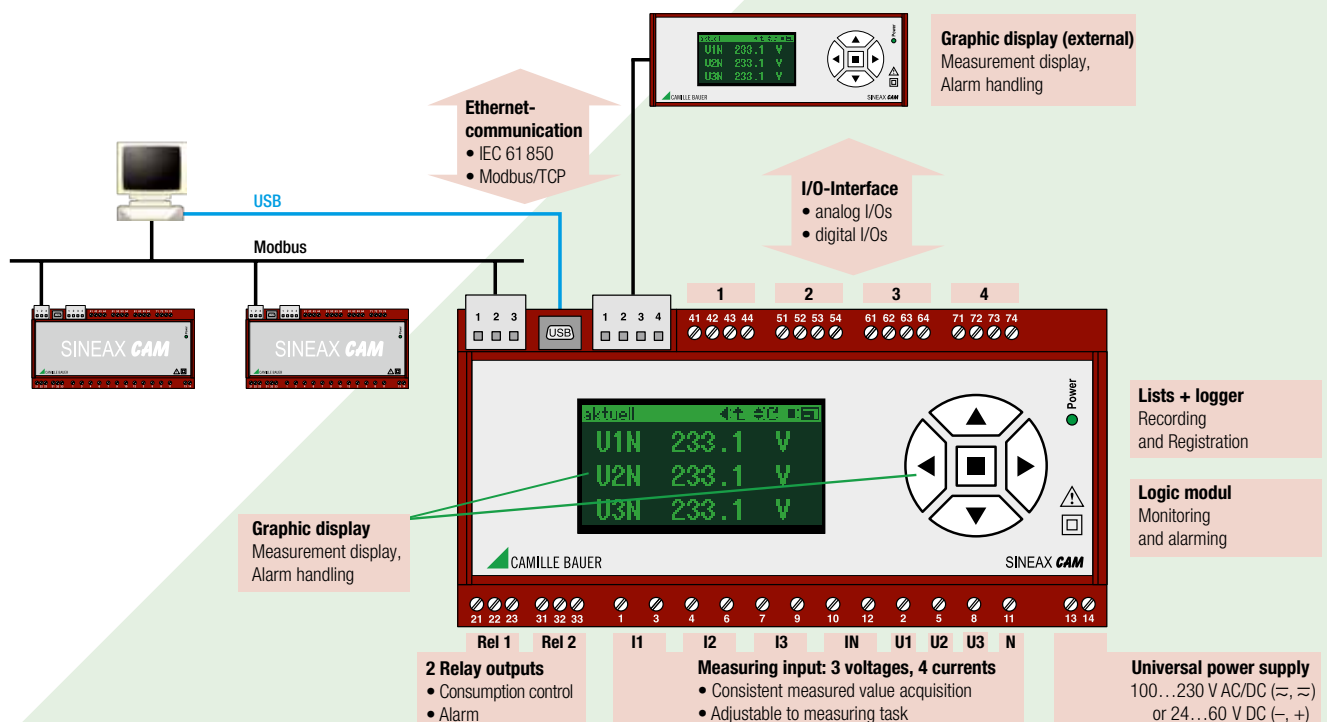

SINEAX CAM

Universal measuring unit for heavy current variables

Applicable standards and regulations

(Issue: May 2006)

IEC/EN 61 010-1	Safety regulations for electrical measuring, control and laboratory equipment
IEC/EN 60 688	Electrical measuring transducers for converting AC electrical variables into analog and digital signals
DIN 40 110	AC quantities
IEC/EN 60 068-2-1/-2/-3/-6/-27:	Ambient tests -1 Cold, -2 Dry heat, -3 Damp heat, -6 Vibration, -27 Shock
IEC/EN 60 529	Protection types by case
IEC/EN 61 000-6-2/-6-4:	Electromagnetic compatibility (EMC), Generic standard for industrial environments
IEC/EN 61 131-2	Programmable controllers – Equipment requirements and tests
IEC/EN 61 326	Electrical equipment for measurement, control and laboratory use – EMC requirements
IEC/EN 62 053-31	Pulse output devices for electromechanical and electronic meters (two wires only)
UL94	Tests for flammability of plastic materials for parts in devices and appliances

Technical data

Measurement input

Rated frequency:	50 ... 60 Hz
Measurement TRMS:	Up to the 63 rd harmonic
Measurement category:	≤ 300 V CATIII, ≤ 600 V CATII

Current measurement

Rated current:	1 A (+ 20%), 1 A (+ 100%), 5 A (+ 20%), 5 A (+ 100%)
Overriding max.:	10 A (sinusoidal)
Consumption:	≤ I ² x 0.01Ω per phase
Thermal ratings:	12 A continuous 100 A, 10 x 1 s, interval 100 s

Instead of current inputs the version for Rogowski coils provides voltage inputs of nominal 5 V (max. 10 V).

Voltage measurement

Rated voltage:	57.7 ... 400 V _{LN} , 100 ... 693 V _{LL}
Overriding max.	600 V _{LN} , 1040 V _{LL} (sinusoidal)
Consumption:	≤ U ² / 3 MΩ per phase
Input impedance:	3 MΩ per phase

Thermal ratings:

480 V_{LN}, 832 V_{LL} continuous
600 V_{LN}, 1040 V_{LL}, 10 x 10 s,
interval 10 s
800 V_{LN}, 1386 V_{LL}, 10 x 1 s,
interval 10 s

System

Single-phase	1L
Split Phase	2L
3-wire system, balanced load	3Lb
3-wire system, unbalanced load	3Lu
3-wire system, unbalanced load (Aron)	3Lu.A
4-wire system, balanced load	4Lb
4-wire system, unbalanced load	4Lu
4-wire system, unbalanced load (Open-Y)	4Lu.O

Basic accuracy under reference conditions acc. IEC/EN 60 688

Voltage:	± 0.1% FS ^{a)}
Current:	± 0.1% FS ^{a)}
Power:	± 0.2% FS ^{b)}
Power factor:	± 0.1°
Frequency:	± 0.01 Hz
Voltage unbalance:	± 0.2%
Harmonics:	± 0.5%
THD Voltage:	± 0.5%
TDD Current:	± 0.5%
Energy:	± 0.2% FS ^{b)}
Active energy direct connection:	KI. 1 / EN 62 053-21
Active energy transformer connection:	KI. 2 / EN 62 053-21
Reactive energy:	KI. 2 / EN 62 053-23

Influence quantities and permissible variations

According to IEC/EN 60 688

Additional error due to system configuration

Neutral N not connected (3Lu, 3Lu.A):

Voltage	0.1% of Reading
Power	0.1% of Reading
Energy	Voltage influence x 2, Angle error x 2
Power factor	0.1°

^{a)} FS: Maximum value of the input configuration (Full Scale)

^{b)} FS: FS-Voltage x FS-Current

Universal measuring unit for heavy current variables

Interrupted input signal:

Voltage	0.2% FS
Current	0.2% FS
Power	0.5% FS
Energy	Basic accuracy x 3
Power factor	0.1°

Measurement with fixed frequency:

General	\pm basic acc. x $(F_{\text{konfig}} - F_{\text{ist}})$ [Hz] x 10
Voltage unbalance	$\pm 1.5\%$ till ± 0.5 Hz
Harmonics	$\pm 1.5\%$ till ± 0.5 Hz
THD, TDD	$\pm 2.0\%$ till ± 0.5 Hz

Zero suppression, Range limitations

PF	1, if Sx	< 0.2% range-S
QF, LF	0, if Sx	< 0.2% range-S
Current	0, if Ix	< 0.1% range-I
unb. U	0, if $\emptyset U$	< 5.0% range-U
H-U, THD-U	0, if H1	< 5.0% range-U
H, THD, TDD, unb. U	0, if ΔF longer than 1s > 5 Hz/s	
F	45 ... 65 Hz or 10 ... 70 Hz	

range-U for voltage input configuration line to line secondary max.:

$\leq 132 V_{LL}$	Range <u>range-U</u> = $76.2 V_{LN'}$, $132 V_{LL}$
$\leq 264 V_{LL}$	Range <u>range-U</u> = $152.4 V_{LN'}$, $264 V_{LL}$
$\leq 528 V_{LL}$	Range <u>range-U</u> = $304.8 V_{LN'}$, $528 V_{LL}$
$\leq 1040 V_{LL}$	Range <u>range-U</u> = $600.0 V_{LN'}$, $1040 V_{LL}$

range-I for current input configuration secondary max.:

≤ 1.2 A	Range <u>range-I</u> = 1.2 A
≤ 2.0 A	Range <u>range-I</u> = 2.0 A
≤ 6.0 A	Range <u>range-I</u> = 6.0 A
≤ 10.0 A	Range <u>range-I</u> = 10.0 A

range-S Range range-S = range-U x range-I

Relationship between PF, QF and LF

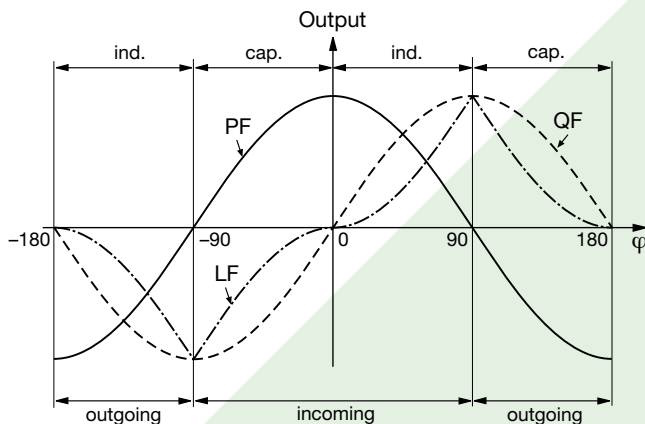

Fig. 2. Active power factor PF —, reactive power factor QF -----, power factor LF - - - - -.

Measurement calculation acc. DIN 40 110 incl. 4-quadrant measurement.

Basic measurement quantities

Measured quantity	present	max	min	1L	2L	3Lb	3Lu	3Lu.A	4Lb	4Lu	4Lu.0
Voltage U	●	●	●	✓	✓				✓		
Voltage U1N	●	●	●		✓					✓	✓
Voltage U2N	●	●	●		✓					✓	✓
Voltage U3N	●	●	●							✓	✓
Voltage U12	●	●	●			✓	✓	✓		✓	✓
Voltage U23	●	●	●			✓	✓	✓		✓	✓
Voltage U31	●	●	●			✓	✓	✓		✓	✓
Voltage UNE	●	●								✓	✓
Current I	●	●		✓		✓			✓		
Current I1	●	●			✓		✓	✓		✓	✓
Current I2	●	●			✓		✓	✓		✓	✓
Current I3	●	●					✓	✓		✓	✓
I-Bimetal 1-60 min IB	●	●		✓		✓			✓		
I1-Bimetal 1-60 min IB1	●	●			✓		✓	✓		✓	✓
I2-Bimetal 1-60 min IB2	●	●			✓		✓	✓		✓	✓
I3-Bimetal 1-60 min IB3	●	●					✓	✓		✓	✓
Neutral current IN	●	●			✓					✓	✓
Active power Σ P	●	●		✓	✓	✓	✓	✓	✓	✓	✓
Active power P1	●	●			✓					✓	✓
Active power P2	●	●			✓					✓	✓
Active power P3	●	●								✓	✓
Reactive power Σ Q	●	●		✓	✓	✓	✓	✓	✓	✓	✓
Reactive power Q1	●	●			✓					✓	✓
Reactive power Q2	●	●			✓					✓	✓
Reactive power Q3	●	●								✓	✓
Apparent power Σ S	●	●		✓	✓	✓	✓	✓	✓	✓	✓
Apparent power S1	●	●			✓					✓	✓
Apparent power S2	●	●			✓					✓	✓
Apparent power S3	●	●								✓	✓
Frequency F	●	●	●	✓	✓	✓	✓	✓	✓	✓	✓
Active power factor Σ PF	●			✓	✓	✓	✓	✓	✓	✓	✓
Active power factor PF1	●				✓					✓	✓
Active power factor PF2	●				✓					✓	✓
Active power factor PF3	●									✓	✓
PF Σ Incoming ind.			●	✓	✓	✓	✓	✓	✓	✓	✓
PF Σ Incoming cap.			●	✓	✓	✓	✓	✓	✓	✓	✓
PF Σ Outgoing ind.			●	✓	✓	✓	✓	✓	✓	✓	✓
PF Σ Outgoing cap.			●	✓	✓	✓	✓	✓	✓	✓	✓
React. power factor Σ QF	●			✓	✓	✓	✓	✓	✓	✓	✓
React. power factor QF1	●				✓					✓	✓
React. power factor QF2	●				✓					✓	✓
React. power factor QF3	●									✓	✓
LF power factor Σ LF	●			✓	✓	✓	✓	✓	✓	✓	✓
LF power factor LF1	●				✓					✓	✓
LF power factor LF2	●				✓					✓	✓
LF power factor LF3	●									✓	✓
(U1N+U2N) / 2 Um	●				✓						
(U1N+U2N+U3N) / 3 Um	●									✓	✓
(U12+U23+U31) / 3 Um	●						✓	✓			
(I1+I2) / 2 Im	●				✓						
(I1+I2+I3) / 3 Im	●						✓	✓		✓	✓

SINEAX CAM

Universal measuring unit for heavy current variables

System analysis quantities

Measured quantity		present	max	1L	2L	3Lb	3Lu	3LuA	4Lb	4Lu	4Lu.0
Voltage unbalance	unb. U	•	•							✓	✓
THD Voltage	THD.U1N	•	•	✓	✓				✓	✓	✓
THD Voltage	THD.U2N	•	•		✓					✓	✓
THD Voltage	THD.U3N	•	•							✓	✓
THD Voltage	THD.U12	•	•			✓	✓	✓			
THD Voltage	THD.U23	•	•			✓	✓	✓			
THD Voltage	THD.U31	•	•			✓	✓	✓			
TDD Current	TDD.I1	•	•	✓	✓	✓	✓	✓	✓	✓	✓
TDD Current	TDD.I2	•	•		✓		✓	✓		✓	✓
TDD Current	TDD.I3	•	•				✓	✓		✓	✓
Harmonics	H2-50.U1	•	•	✓	✓				✓	✓	✓
Harmonics	H2-50.U2	•	•		✓					✓	✓
Harmonics	H2-50.U3	•	•							✓	✓
Harmonics	H2-50.U12	•	•			✓	✓	✓			
Harmonics	H2-50.U23	•	•			✓	✓	✓			
Harmonics	H2-50.U31	•	•			✓	✓	✓			
Harmonics	H2-50.I1	•	•	✓	✓	✓	✓	✓	✓	✓	✓
Harmonics	H2-50.I2	•	•		✓		✓	✓		✓	✓
Harmonics	H2-50.I3	•	•				✓	✓		✓	✓

THD U (Total Harmonic Distortion): Harmonic content related to the fundamental of the RMS value of voltage.

TDD I (Total Demand Distortion): Harmonic content related to the fundamental of the RMS value of the rated current.

Energy meters (high and low tariff)

Active energy:	Incoming
Active energy:	Outgoing
Reactive energy:	Incoming
Reactive energy:	Outgoing
Reactive energy:	Inductive
Reactive energy:	Capacitive

I/O-Interface

Relay

Number:	2
Contacts:	Changeover contact
Load capacity:	250 V AC, 2 A, 500 VA 30 V DC, 2 A, 60 W

I/O-Module (optional)

Up to 4 different groups of terminals (41-44, 51-54, 61-64, 71-74) with defined input/output functions are available depending on the selected options. These groups are galvanically isolated from each other and from the rest of the device.

The following modules are available:

Analog outputs

2 active current outputs per group of terminals	
Function	On-site display, PLC

Linearization:	Linear, quadratic, kinked
Range:	0/4-20 mA (24 mA max.), unipolar or ± 20 mA (24 mA max.), bipolar
Accuracy:	± 0.1% of 20 mA
Burden:	≤ 500 Ω (max. 10 V / 20 mA)
Burden influence:	≤ 0.1%
Residual ripple:	≤ 0,2%
Galvanical isolation:	From all other connections (connected within group of terminals)

Analog inputs

2 current inputs per group of terminals	
Function:	External measured variable (e.g. temperature), Summing for meters, Scalable as required, Pollable via interface
Range:	0/4 - 20 mA (24 mA max.) unipolar
Accuracy:	± 0.1% of 20 mA
Input resistance:	< 40 Ω
Galvanical isolation:	From all other connections (connected within group of terminals)

Digital inputs/outputs

3 per group of terminals, in relation to software configurable as passive inputs or outputs (all the same), acc. EN 61 131-2

Inputs (acc. EN 61 131-2 DC 24 V Type 3):

Function	State acquisition, Trigger / enabling signal, Pulse input for meter
Rated voltage	12 / 24 V DC (30 V max.)
Input current	< 7.0 mA
Counting frequency (S0)	≤ 50 Hz
Logical ZERO	- 3 till + 5 V
Logical ONE	8 till 30 V
Switching limit	Approx. 6.5 V / 2.6 mA

Outputs (partly acc. EN 61 131-2):

Function	Alarm, State message, Pulse output
Rated voltage	12 / 24 V DC (30 V max.)
Rated current	50 mA (60 mA max.)
Switching frequency (S0)	≤ 20 Hz
Leakage current	0.01 mA
Voltage drop	< 3 V
Load capacity	400 Ω ... 1 MΩ
Fuse	Self-regulating

Digital inputs 125 V DC

3 per group of terminals	
Function	State acquisition, Trigger / enabling signal, Pulse input for meter
Rated voltage	48 / 125 V DC (157 V max.)
Input current	< 2.5 mA
Counting frequency (S0)	≤ 50 Hz

SINEAX CAM

Universal measuring unit for heavy current variables

Logical ZERO	- 6 till + 20 V
Logical ONE	30 till 157 V
Switching limit	Approx. 25 V / 0.8 mA

Interface

Modbus connection (plug-in screw terminals 1, 2, 3)

Function:	Configuration, measurement acquisition
Protocol:	Modbus RTU
Physics:	RS-485, max. distance 1200 m (4000 ft)
Baudrate:	Configurable (1.2 till 115.2 kBaud)
Number of bus stations:	≤ 32

USB connection (USB Mini-B, 5 contacts)

Function:	Configuration, measurement acquisition
Protocol:	USB 2.0

Subbus connection (plug-in screw terminals 1, 2, 3, 4)

Function:	reserved for future device options
-----------	------------------------------------

Ethernet (RJ-45), optional

Function:	Configuration, measurement acquisition
Protocol:	Modbus/TCP or IEC 61850 (depending on the version ordered)

Power supply

Option 1

AC, 50 – 400 Hz:	100 ... 230 V ± 15%
DC:	100 ... 230 V ± 15%
Consumption:	≤ 10 W resp. ≤ 20 VA
Inrush current:	< 25 A / 0.3 ms
System voltage drop with optional I/Os:	< 200 ms (230 V AC) < 40 ms (115 V AC)
System voltage drop without optional I/Os:	< 400 ms (230 V AC) < 80 ms (115 V AC)

Option 2

DC:	24 ... 60 V ± 15%
Consumption:	≤ 10 W

Limit module (Software function)

64 limit values for monitoring measurement limits	
Limit for ON state:	Programmable
Limit for OFF state:	Programmable

Logic module (Software function)

32 logic functions to combine logical states: Limit values, digital inputs, LS-states and default values. Output to digital outputs, relays or other logic functions possible.

Response time

The total response time is the addition of the measurement time t_1 of the input quantities and the processing time t_2 for the respective output (analog output, bus, digital output, relay).

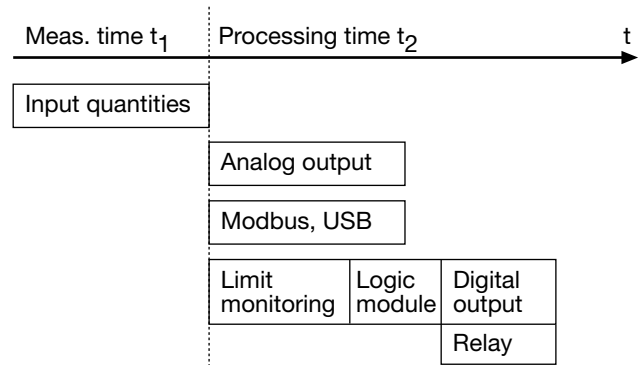

Measurement time t_1

Basic measurement quantities

Measurement interval:	Programmable, 1 ... 999 periods (averaging time RMS value)
Measurement time t_1 :	2 x measurement interval + 17 ms

System analysis quantities

Measurement interval:	18 periods
Measurement time t_1 :	2 x measurement interval

Analog input

Measurement time t_1 :	25 ms ... 30 s (programmable)
--------------------------	-------------------------------

Digital input

Measurement time t_1 :	< 25 ms
--------------------------	---------

Total response time $t_1 + t_2$

Analog output:	$t_1 + 10 \text{ ms} \dots 60 \text{ s}$, programmable
Modbus / USB:	t_1
Digital output:	$t_1 + 8 \text{ ms} + \text{logic module}$
Relay:	$t_1 + 30 \text{ ms} + \text{logic module}$

(Logic module: Switch-in/dropout delay 0 ... 65 s, programmable)

Example: Relay has to toggle if $P > P_{\text{limit}}$, rated frequency is 50 Hz, averaging time is 1 period, switch-in delay logic set to 0 s

Response time
 $40 \text{ ms} + 17 \text{ ms} + 0 \text{ ms} + 30 \text{ ms} = 87 \text{ ms}$

SINEAX CAM

Universal measuring unit for heavy current variables

Internal clock (RTC)

Function:	Time reference, counter for operating hours
Accuracy:	± 2 minutes / month (15 till 30°C), trimmable via PC-Software
Synchronization via:	Measurement input, HV-Input 110/230 V AC, synchronization pulse (digital input)
Running reserve:	> 10 years

Vibration withstand (tested according to DIN EN 60 068-2-6)

Acceleration:	± 5 g
Frequency range:	10 ... 150 ... 10 Hz, rate of frequency sweep: 1 Oktave/Minute
Number of cycles:	10 in each of the three axes
Result:	No faults occurred, no loss of accuracy and no problems with the snap fastener

Ambient conditions, general information

Operating temperature:	- 10 till 15 till 30 till + 55 °C
Storage temperature:	- 25 till + 70 °C
Variations due to ambient temperature:	0.5 x basic accuracy per 10 K
Long term drift:	0.2 x basic accuracy per year
Others:	Usage group II according IEC/EN 60 688
Relative humidity:	< 95% no condensation
Altitude:	≤ 2000 m max.
Indoor use statement!	

Mechanical attributes

Dimensions:	186 x 90 x 62 mm
Mounting:	On top-hat rail acc. DIN EN 50 022 (35 x 15 mm and 35 x 7.5 mm)
Orientation:	Any
Housing material:	Polycarbonat (Makrolon)
Flammability class:	V-0 acc. UL94, self-extinguishing, non-dripping, free of halogen
Weight:	500 g

Security

The current inputs are galvanically isolated from each other.

Protection class:	II (protective insulation, voltage inputs via protective impedance)
Pollution degree:	2
Protection:	IP40, housing (test wire, IEC/EN 60 529) IP20, Terminals (test finger, IEC/EN 60 529)
Measurement category:	CAT III (at ≤ 300 V versus earth) CAT II (at > 300 V versus earth)
Rated voltage (versus earth):	Power supply: 265 V AC

Relay:	250 V AC
I/O's:	30 V DC (Low-Level) 264 V AC(HV-Input)

Test voltages:	DC, 1 min., acc. IEC/EN 61 010-1 4920 V DC, power supply versus inputs U I, Bus, USB, I/O's, Relay 4920 V DC, inputs U versus relay, HV-Input 3130 V DC, inputs U versus inputs I, Bus, USB, Low Level I/O's 4920 V DC, inputs I versus Bus, USB, I/O's, Relay 4690 V DC, inputs I versus inputs I 4920 V DC, relay versus relay 4250 V DC, relay versus Bus, USB, I/O's
----------------	---

Graphic display (optional)

The graphic display is intended for on-site visualization of measurements, lists and alarms. Via keypad the user can e.g. acknowledge alarms or reset extreme values.

The parametrization of the graphic display and the assembling of user specific measurement displays is performed using the CB-Manager software. Parameters like contrast or the selection of the display language (English, German, French, Czech, Spanish, Dutch, Italian) can be set also directly using the keypad.

The operation of the graphic display is described in a separate document, which is attached in English and German to all devices equipped with display. The appropriate manuals for all languages may be found on the provided software CD.

Rogowski current inputs (optional)

See appendix A

Logger and lists (optional)

By means of these options measurement and event data may be long-term recorded. Depending on the application 9 different kinds of data may be acquired:

- Progression of mean-values with interval time t1 (1s...60 min)
- Progression of mean-values with interval time t2 (1s...60 min)
- Min/Max values during interval t3 (1s ... 3h)
- Meter readings
- List entries of alarms
- List entries of events
- List entries of system messages

They share the available storage space of 64Mb size. The memory allocation may be performed using the CB-Manager software. Due to the high degree of freedom for the configuration of logger and lists no general information about the maximal storage duration can be given. But these can be seen in the software when selecting the memory allocation, the measurands to store and the number of list entries.

The reading and analyzing of logger and list data can be done using the **CB-Analyzer** software.

Ethernet with Modbus/TCP protocol (optional)

Ethernet provides a transmission medium with high bandwidth for analyzing measured data in real-time. CAM supports the protocols Modbus/TCP and NTP. *Modbus/TCP* is a common used standard which is supported by a large number of visualization software tools and thus allows a fast implementation of the device. Via the Modbus/TCP interface all functions are supported, which are possible using the Modbus/RTU or USB interface.

Universal measuring unit for heavy current variables

For the *time synchronization* of devices via Ethernet, *NTP* (Network Time Protocol) is the standard. Respective time servers are used in computer networks and are at free disposal via Internet as well. By means of NTP all devices can be used with a common time base.

Applications

- Test stands for aggregates: Recording of the dynamic behaviour of motors and generators.
- Remote monitoring and acquisition of power distribution systems via Intranet / Internet.
- Recording of the dynamic loading of energy supply systems.

IEC 61850 support (optional)

The communication standard IEC 61850 (“Communication networks and systems in substations”) is the new standard for substation automation. The CAM with IEC 61850 support is a measuring device which bases on the application of conventional current and voltage transformers. Therefore it is most suitable for the *modernization of substations*, not touching the already installed conventional transformers. It provides the following logical nodes:

MMXU / MMXN: Instantaneous values of voltages, currents, frequency, power quantities and load factors as well as their maximum and minimum values.

MHAI / MHAN: Individual harmonics for voltage and current, THD (total harmonic distortion) and TDD (total demand distortion) and their maximum values.

MMTR: Active and reactive energy meters for incoming and outgoing power. One instance for both high and low tariff.

MSTA: Mean values of voltage, current, active, reactive and apparent power as well as their maximum and minimum values on instantaneous values base. All measured within the same interval. These values are provided for each phase as well.

MSQI: Imbalance of voltage and current, calculated in accordance with two different methods.

GGIO: Maps the information of assembled analog and digital input modules. So CAM may be used as an IEC 61850 gateway. By means of GGIO instances state information (e.g. ON/OFF or a self-monitoring signal), analog measurements (e.g. a temperature) or metering pulses (kWh / kVArh) of non IEC 61850 capable external devices can be handled. These measurement data then can be accessed via the IEC 61850 interface.

CB-Manager Software

The PC software CB-Manager which is supplied with each device may be used for the parametrization of the SINEAX CAM. Via USB, RS485 or Ethernet interface all measured data can be read and recorded as well.

The access to the device can be restricted by activating a password protection system. For up to 3 users you may selectively grant the right for configuration, reset or simulation functions.

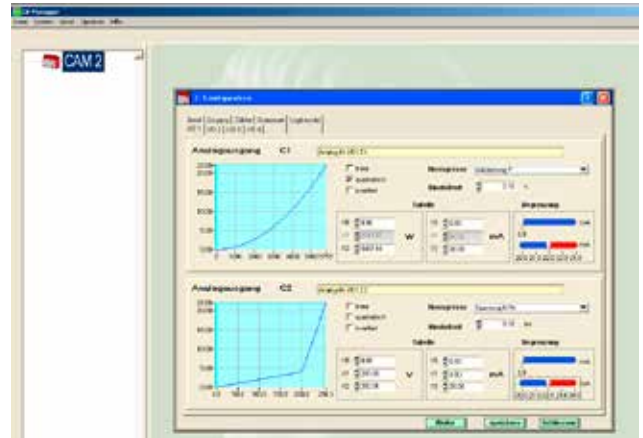

- Complete parametrization of the device (ONLINE, OFFLINE)
- Read and record all measured data
- Archiving of configuration and measurement data
- Setting and resetting meter contents
- Selective resetting of minimum and maximum values
- Setting of interface parameters
- Trimming of analog inputs
- Simulation of I/O-module functionality
- Comprehensive help function

Ordering information

CAM, programmable, Modbus interface, USB	CAM
Features, Selection	
1. Basic device CAM, for top-hat rail mounting	
Without display	1
With graphic display	2
Without display, with Rogowski current inputs (3V power supply)	3
With graphic display and Rogowski current inputs (3V power supply)	4
Without display, with Rogowski current inputs (4.5V power supply)	5
With graphic display and Rogowski current inputs (4.5V power supply)	6
Without display, with Rogowski current inputs (6V power supply)	7
With graphic display and Rogowski current inputs (6V power supply)	8
Without display, with Rogowski current inputs (9V power supply)	9
With graphic display and Rogowski current inputs (9V power supply)	A
2. Input frequency range	
45 ... 50/60 ... 65 Hz	1
10 ... 50/60 ... 70 Hz	2
10 ... 50/60 ... 140 Hz	3

SINEAX CAM

Universal measuring unit for heavy current variables

3. Power supply	
Nominal range 100 ... 230 V AC/DC	1
Nominal range 24 ... 60 V DC	2
4. I/O module 1 (terminals 41-44)	
Not used	0
2 analog outputs, unipolar (0/4...20 mA)	1
2 analog inputs (0/4...20 mA)	2
3 digital outputs or 3 digital inputs 24 V DC	3
2 analog outputs, bipolar ± 20 mA	5
5. I/O module 2 (terminals 51-54)	
Not used	0
2 analog outputs, unipolar (0/4...20 mA)	1
2 analog inputs (0/4...20 mA)	2
3 digital outputs or 3 digital inputs 24 V DC	3
2 analog outputs, bipolar ± 20 mA	5
6. I/O module 3 (terminals 61-64)	
Not used	0
2 analog outputs, unipolar (0/4...20 mA)	1
2 analog inputs (0/4...20 mA)	2
3 digital outputs or 3 digital inputs 24 V DC	3
2 analog outputs, bipolar ± 20 mA	5
7. I/O module 4 (terminals 71-74)	
Not used	0
2 analog outputs, unipolar (0/4...20 mA)	1
2 analog inputs (0/4...20 mA)	2
3 digital outputs or 3 digital inputs 24 V DC	3
2 analog outputs, bipolar ± 20 mA	5
3 digital inputs 125 V DC	6
8. Test certificate	
Without	0
Test certificate in German	D
Test certificate in English	E
9. Option data logger	
Without data logger	0
With data logger	1
10. Option lists	
Without alarm, event, operator list	0
With alarm, event, operator list	1
11. Bus connection	
Without	0
Ethernet, Modbus/TCP-Protocol	1
Ethernet, IEC 61850-Protocol	2

Electrical connections

Screw connections are used. They are designed for cross sections of 4 mm² for single wire leads and 2 x 2.5 mm² for multiwire leads.

Analog outputs

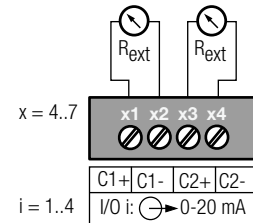

Analog inputs

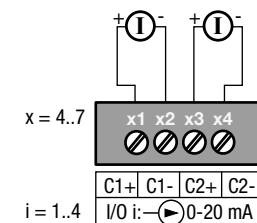

Digital outputs

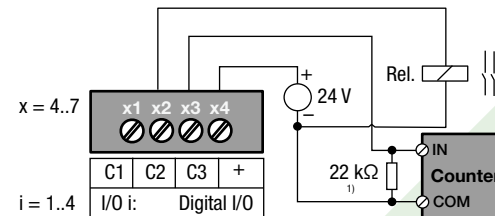

¹⁾ Recommended if input resistance < 100 k Ω

Digital inputs 12/24 V DC

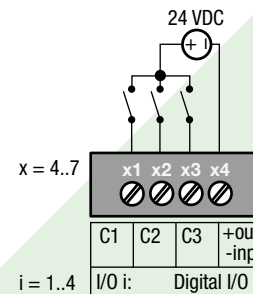

Digital inputs 125 V DC

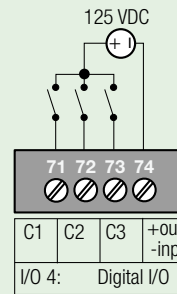

SINEAX CAM

Universal measuring unit for heavy current variables

Connecting modes

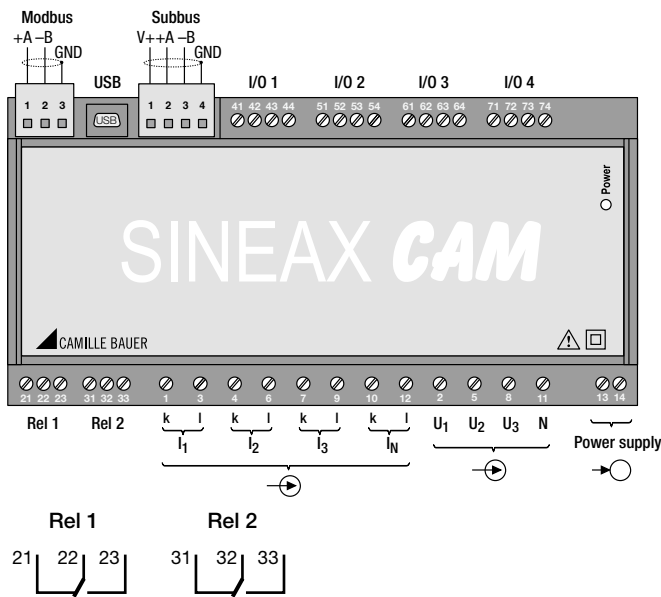

Connecting modes

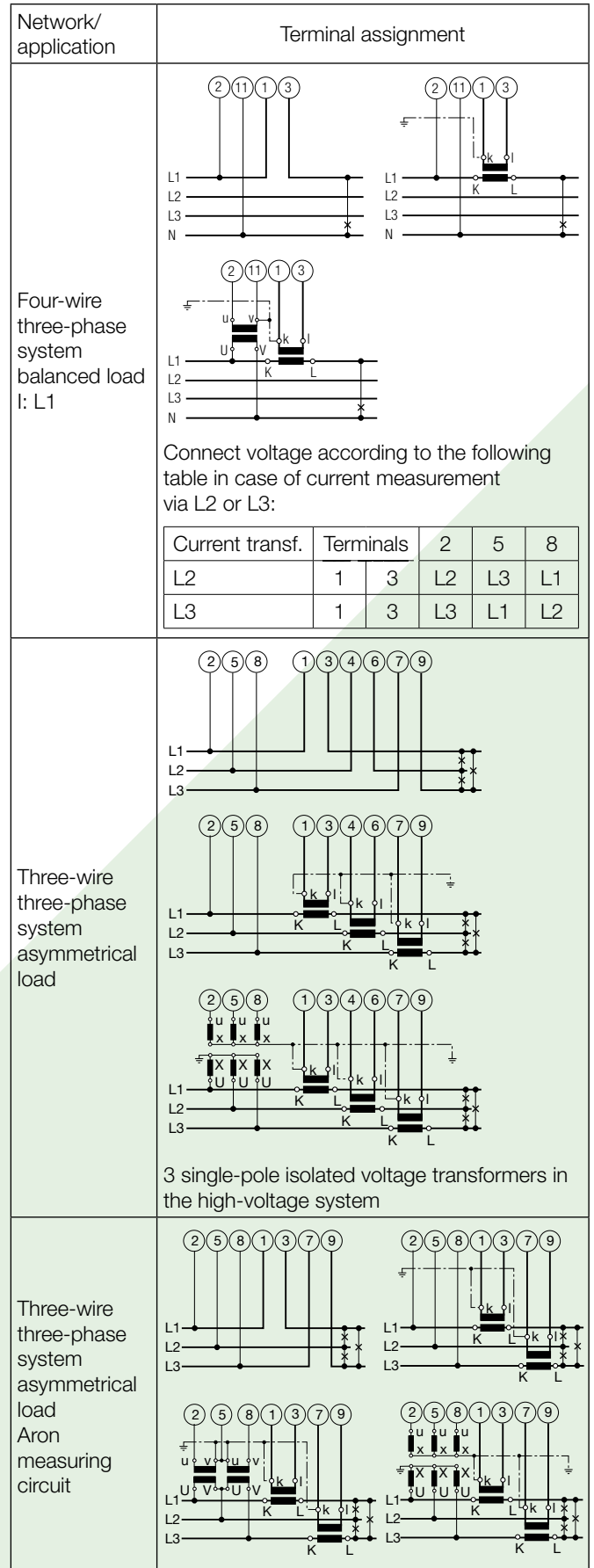
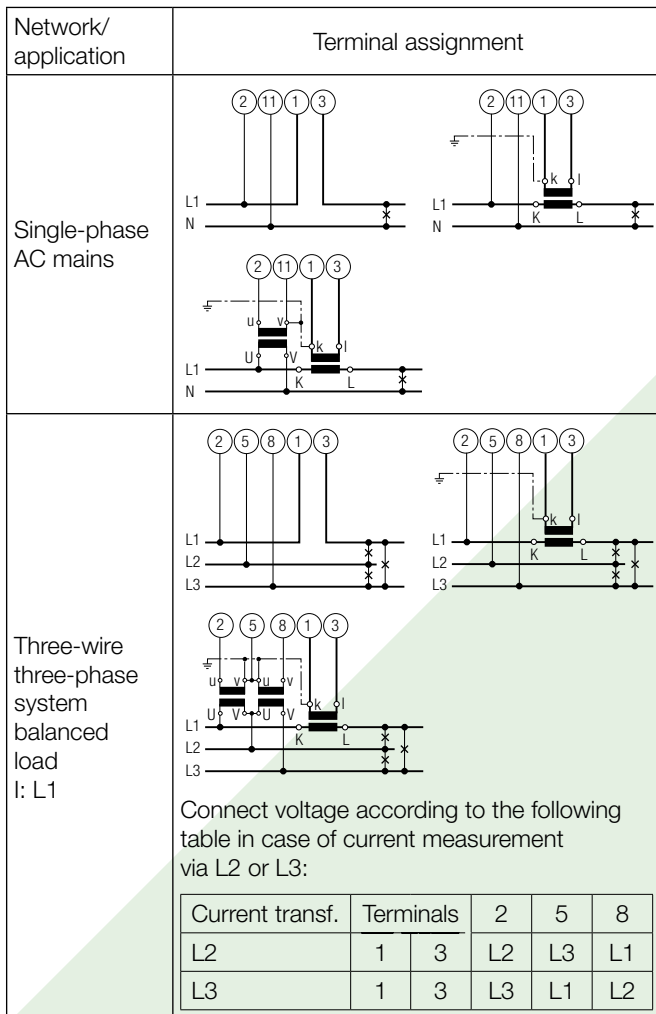

SINEAX CAM

Universal measuring unit for heavy current variables

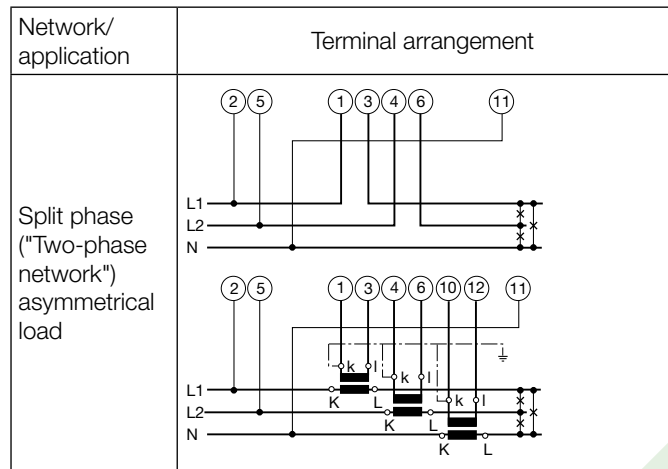
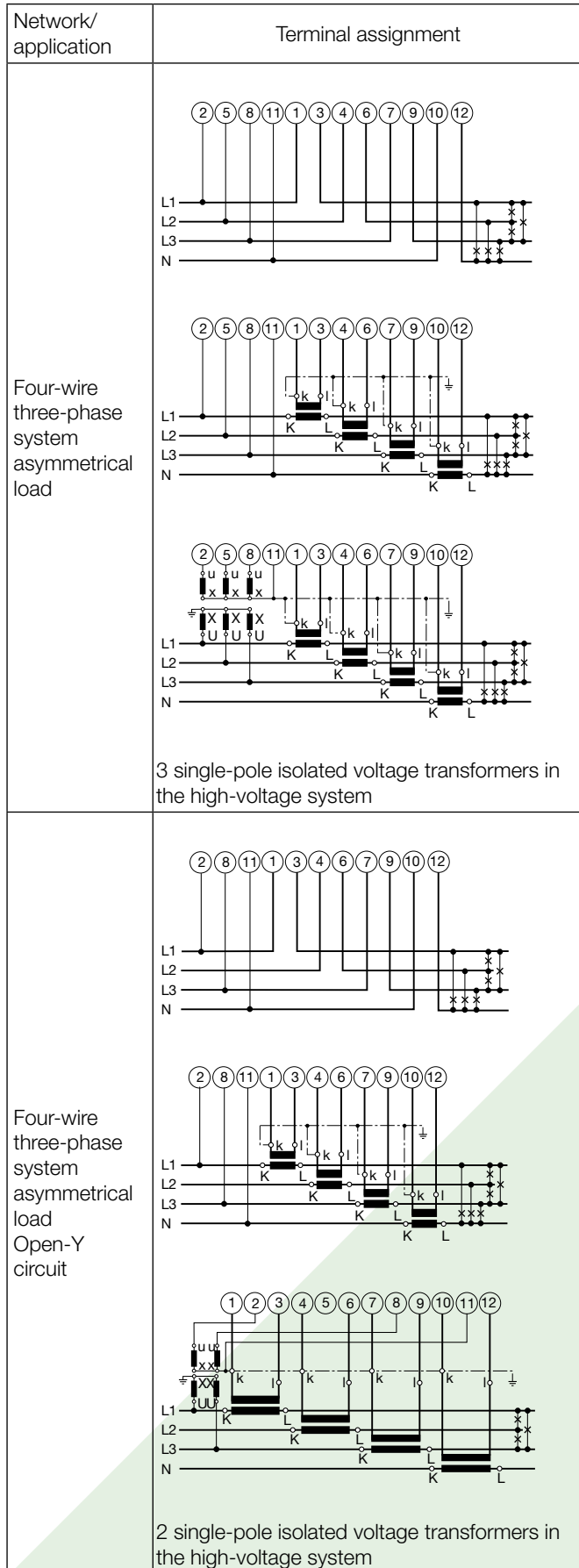

Dimensional drawing

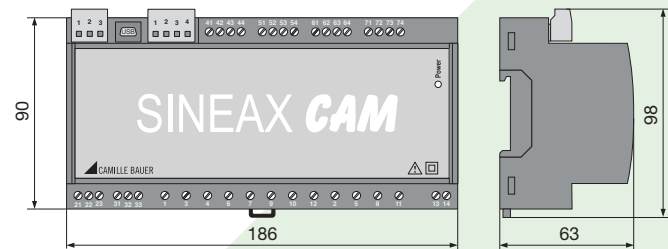

SINEAX CAM in housing clipped onto a top-hat rail (35 x 15 mm or 35 x 7.5 mm). Terminals partly pluggable.

Accessories

Designation	Article Number
Software and documentation CD (within scope of supply)	156027
USB cable (within scope of supply)	158750
Graphic display EDS-CAM, for external panel mounting	157968
Connection cable EDS-CAM to SINEAX CAM, length 2m (other lengths on request)	168949
Interface converter USB <> RS485	163189

SINEAX CAM

Universal measuring unit for heavy current variables

Appendix A

Version with Rogowski current inputs

This version provides instead of current inputs voltage inputs for connecting the integrator circuit of flexible Rogowski coils.

Rogowski coils can be fitted quickly and easily without opening the current circuit and can cover a wide current range using switchable ranges. They can transform fast-changing currents and harmonics much better than conventional current transformers. Thus this version is suited for applications where an accurate analysis of harmonics respectively the corresponding system feedback is required, for monitoring fast changing current flows and for test facilities, where the device under test must be replaced often and quickly.

To allow an application in industrial environment, the power supply of the integrator of the Rogowski coils can be performed directly via the CAM. Because not all coils use the same power supply, different hardware version (3V, 4.5V, 6V und 9V) are offered.

The inputs for connecting the Rogowski coils are designed for 5V and measure up to a maximum of 10V without restriction.

Rogowski coils normally can be used for multiple current ranges, where for a present nominal current input always the same voltage output, normally 3V, results. The switchover of the current measurement range is performed via the rotary-switch on the integrator. The configuration of the CAM for the same current range has to be done separately by means of the CB-Manager software.

Available Rogowski current sensors

Description	Article no.
Single-phase ACP FLEX 3000_5, 2m, Ø194 mm, Measurement ranges 30/300/3000 A, supply 9 V via CAM	169426
Three-phase ACP FLEX 3003_5, 2m, Ø194 mm, Measurement ranges 30/300/3000 A, supply 9 V via CAM	169434

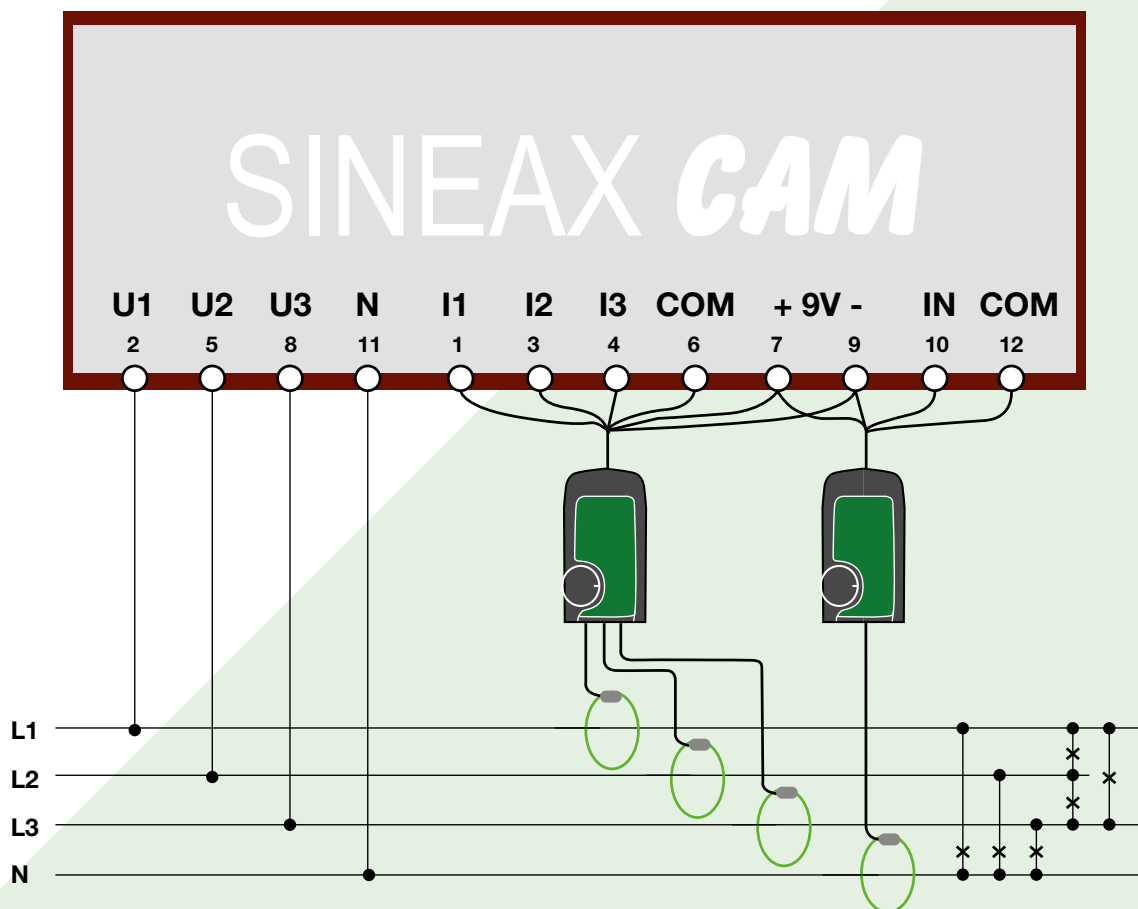

Example with ACP FLEX 300x_5 current sensors 30/300/3000 A, which need a 9 V power supply

По вопросам продажи и поддержки обращайтесь:

Архангельск (8182)63-90-72
Астана (7172)727-132
Астрахань (8512)99-46-04
Барнаул (3852)73-04-60
Белгород (4722)40-23-64
Брянск (4832)59-03-52
Владивосток (423)249-28-31
Волгоград (844)278-03-48
Вологда (8172)26-41-59
Воронеж (473)204-51-73
Екатеринбург (343)384-55-89
Иваново (4932)77-34-06
Ижевск (3412)26-03-58
Казань (843)206-01-48



Калининград (4012)72-03-81
Калуга (4842)92-23-67
Кемерово (3842)65-04-62
Киров (8332)68-02-04
Краснодар (861)203-40-90
Красноярск (391)204-63-61
Курск (4712)77-13-04
Липецк (4742)52-20-81
Магнитогорск (3519)55-03-13
Москва (495)268-04-70
Мурманск (8152)59-64-93
Набережные Челны (8552)20-53-41
Нижний Новгород (831)429-08-12
Новокузнецк (3843)20-46-81

Новосибирск (383)227-86-73
Омск (3812)21-46-40
Орел (4862)44-53-42
Оренбург (3532)37-68-04
Пенза (8412)22-31-16
Пермь (342)205-81-47
Ростов-на-Дону (863)308-18-15
Рязань (4912)46-61-64
Самара (846)206-03-16
Санкт-Петербург (812)309-46-40
Саратов (845)249-38-78
Севастополь (8692)22-31-93
Симферополь (3652)67-13-56
Смоленск (4812)29-41-54

Сочи (862)225-72-31
Ставрополь (8652)20-65-13
Сургут (3462)77-98-35
Тверь (4822)63-31-35
Томск (3822)98-41-53
Тула (4872)74-02-29
Тюмень (3452)66-21-18
Ульяновск (8422)24-23-59
Уфа (347)229-48-12
Хабаровск (4212)92-98-04
Челябинск (351)202-03-61
Череповец (8202)49-02-64
Ярославль (4852)69-52-93

Единый адрес для всех регионов: cmn@nt-rt.ru || www.camille-bauer.nt-rt.ru

PROCESS CONTROL ENGINEERING

ANGULAR POSITION ENGINEERING

HEAVY CURRENT ENGINEERING

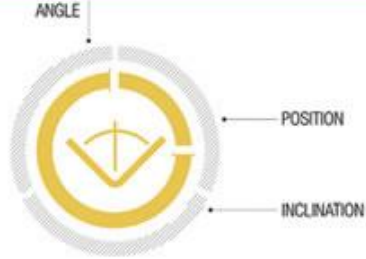